

NOTES:

1. CONSTRUCTION: FORMED AND WELDED HOT ROLLED STEEL
 2. APPROXIMATE WEIGHT: 16,000 LBS.
 3. BOTTOM OF TRANSFORMER ENCLOSURE IS AVAILABLE FOR CONDUIT ENTRY.
 4. ALL EXTERIOR FASTENERS STAINLESS STEEL
 5. SURFACE PREPARATION: ABRASIVE CLEANED OR CHEMICALLY CLEANED AND PHOSPHATIZED
- FINISH COLOR: ASA 49 GRAY
 PRIMER: TILE CLAD WB EPOXY
 (24702501), PART A, B73A200, GRAY PRIMER
 (24702502), PART B, B73V200, CATALYST
- PAINT: CENTURION POLYURETHANE
 (24708500), B65W711, ASA 49 GRAY
 (24722500), B65V700, CATALYST

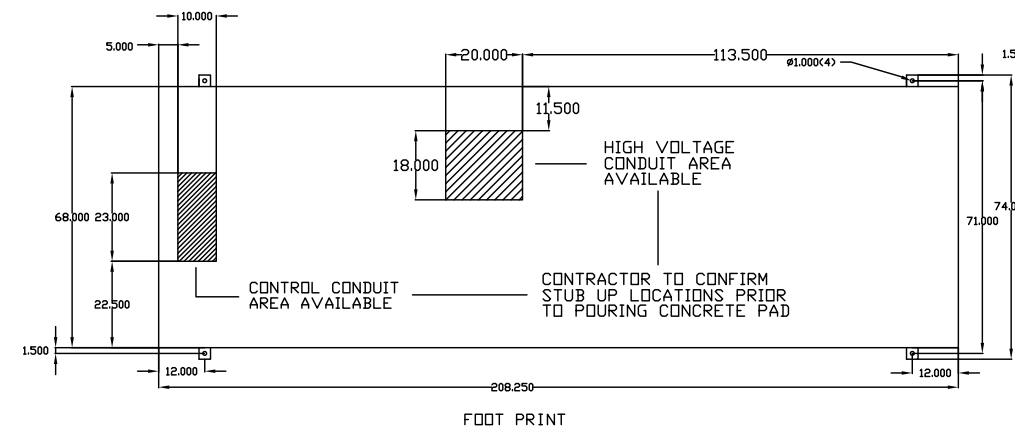

SIMPLEX			SPRINGFIELD, ILLINOIS
SCALE :	APPROVED BY :	DRAWN BY : RER	
DATE : 08-02-10		REVISED :	
MARS-HV LOAD BANK PICTORIAL			
STANDARD			DRAWING NUMBER 211945

THE INFORMATION HEREON IS THE PROPERTY OF SIMPLEX, INC., AND/OR ITS SUBSIDIARIES. WITHOUT WRITTEN PERMISSION ANY COPYING, TRANSMITTAL TO OTHERS AND USE EXCEPT THAT FOR WHICH IT IS LOANED IS PROHIBITED. DESIGN SUBJECT TO CHANGE WITHOUT NOTICE.
 ©2010 SIMPLEX, INC. ALL RIGHTS RESERVED.