

- 1) TRAILER CONSTRUCTION CONFORMS TO APPLICABLE FEDERAL AND DOT STANDARDS  
 5000 LB. GROSS WEIGHT CAPACITY  
 ICC SAFETY PLATED CHAINS 36" LONG W/HOOKS  
 ICC 12V. ELECTRIC LIGHTS WITH 7 POLE CONNECTOR (MALE & FEMALE COMPONENT)  
 (INCLUDES STOP, TURN, BRAKE, AND WIRE HARNESS)  
 ELECTRIC BRAKES, AND MECHANICAL PARKING BRAKE  
 4 LEAF SPRINGS 26" EYE TO EYE -2500#/PAIR  
 3" PINTLE RING  
 2000# LIFT JACK AND CASTER  
 TIRES ST205-75-R14,C @ 1760# CAPACITY EACH  
 HUB AND BEARING ASSEMBLY-CAST IRON W/AUTOMOTIVE BEARINGS  
 DUAL FENDERS  
 DECK PLATE 12 GA. HRS  
 FRAME-FORMED STEEL CHANNEL

PAINTED:  
 PRIMER: TILE CLAD WB EPOXY  
 (24702501),  
 (24702502),  
 PART A, B73A200, GRAY PRIMER  
 PART B, B73V200, CATALYST  
 PAINT: CENTURIAN POLYURETHANE  
 (24708500),  
 (24722500),  
 B65W711, ASA 49 GRAY  
 B65V700, CATALYST

- 2) AIR COOLED LOAD BANK  
 LOAD SECTION-NEMA 3R  
 EXHAUST VERTICAL DISCHARGE HINGED DOOR  
 WITH THE FOLLOWING FEATURES:  
 STEEL STRUCTURE  
 DIRECT DRIVE MOTOR MOUNTED 42"Ø FAN (PROPELLER TYPE)  
 SECURELY BOLTED TO TRAILER

PAINTED:  
 PRIMER: TILE CLAD WB EPOXY  
 (24702501),  
 (24702502),  
 PART A, B73A200, GRAY PRIMER  
 PART B, B73V200, CATALYST  
 PAINT: CENTURIAN POLYURETHANE  
 (24708500),  
 (24722500),  
 B65W711, ASA 49 GRAY  
 B65V700, CATALYST

- 3) APPROXIMATE SHIPPING WEIGHT 5,000 LBS.

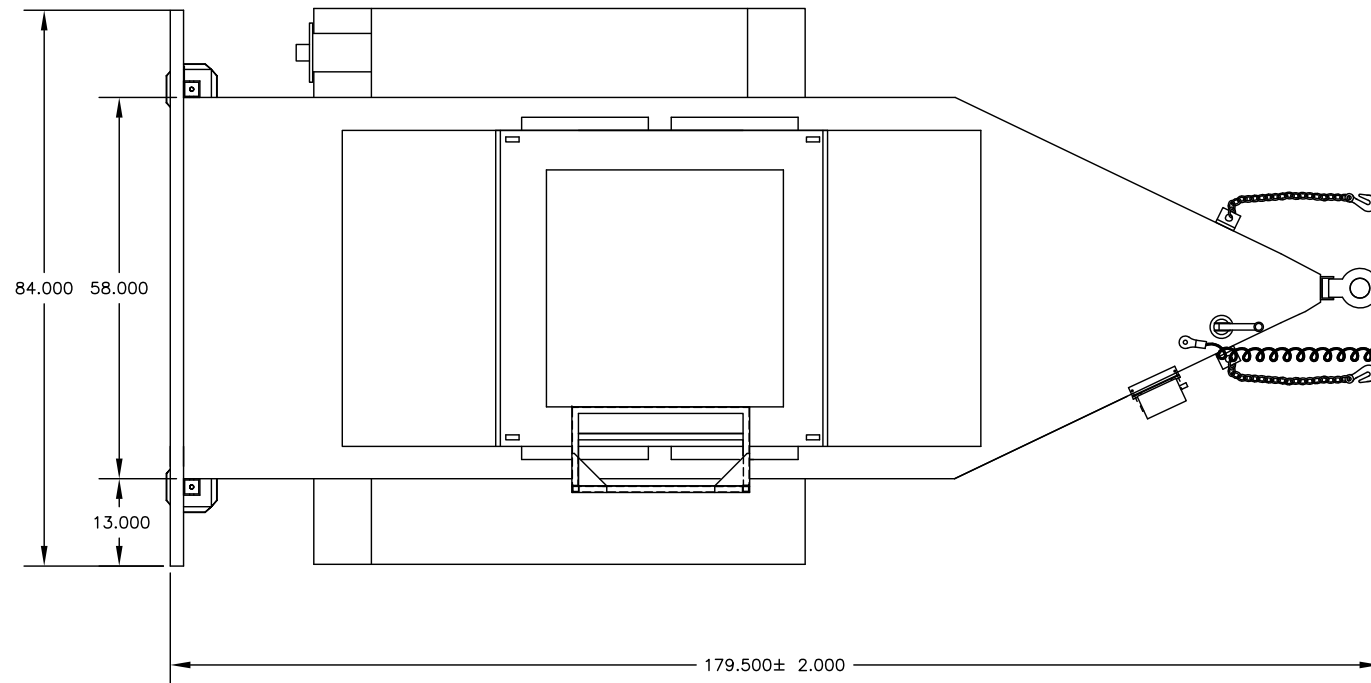

⚠ WARNING - HIGH TEMPERATURE ⚠

EXHAUST TEMPERATURES COULD EXCEED 500°F DURING LOAD TESTS. THIS HIGH TEMPERATURE AIR IS EXHAUSTED AT A HIGH VELOCITY AND EXTENDS OUT THE TOP OF THE LOAD BANK. EXTREME CAUTION SHOULD BE EXERCISED TO PREVENT THIS HOT AIR FROM STRIKING EQUIPMENT OR PROPERTY WHICH COULD BE DAMAGED BY HIGH TEMPERATURES.

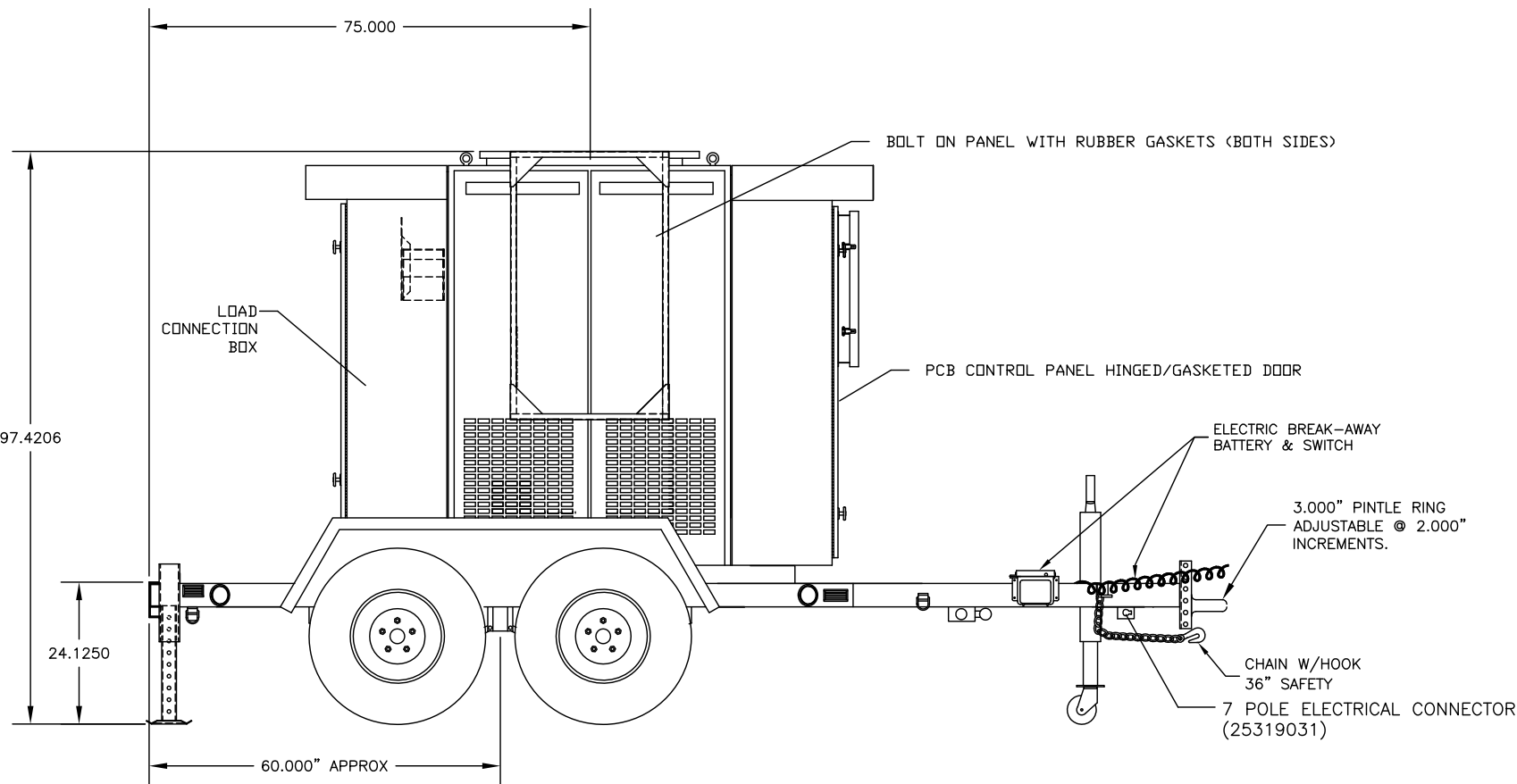
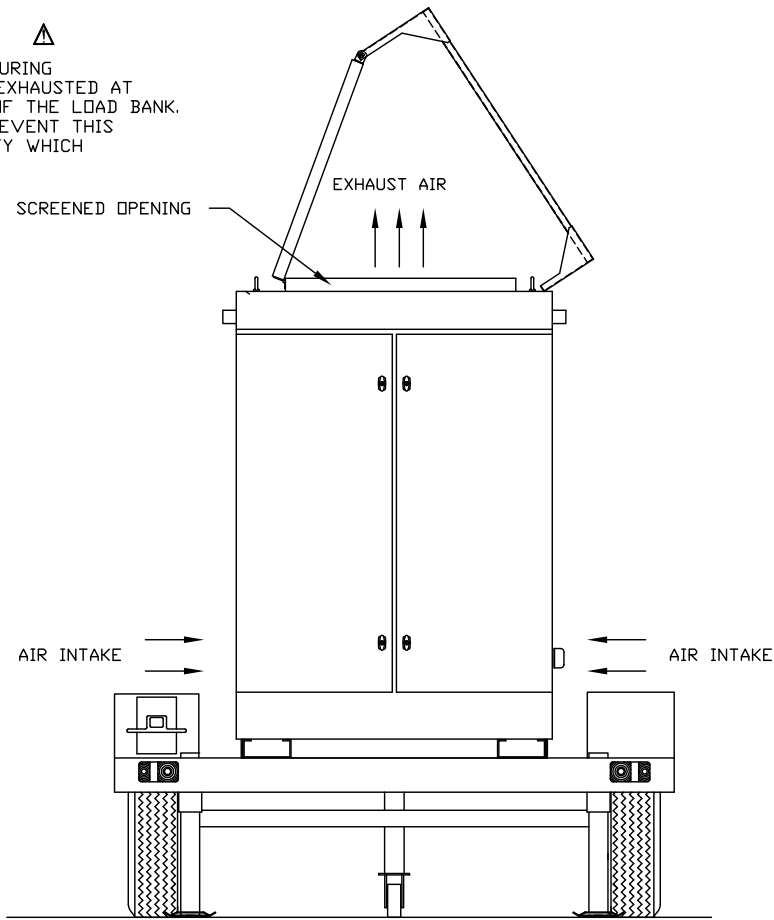

THE INFORMATION HEREON IS THE PROPERTY OF SIMPLEX, INC., AND/OR ITS SUBSIDIARIES. WITHOUT WRITTEN PERMISSION ANY COPYING, TRANSMITTAL TO OTHERS AND USE EXCEPT THAT FOR WHICH IT IS LOANED IS PROHIBITED. DESIGN SUBJECT TO CHANGE WITHOUT NOTICE.  
 ©2010 SIMPLEX, INC. ALL RIGHTS RESERVED.

|  |                |                       |
|--|----------------|-----------------------|
| <b>SIMPLEX</b>                             |                | SPRINGFIELD, ILLINOIS |
| SCALE :                                    | APPROVED BY :  | DRAWN BY : RER        |
| DATE : 08-02-10                            |                | REVISED :             |
| ATLAS-MEGAWATT TRAILER LOAD BANK PICTORIAL |                |                       |
| STANDARD                                   | DRAWING NUMBER | 211951                |