

TANK FITTING SCHEDULE

PORT	DESCRIPTION	
A	ENGINE SUPPLY DROP TUBE	0.75" NPT, MALE
B	SIPHON DRAIN DROP TUBE	0.75" NPT, MALE
C	TANK OVERFLOW PORT (NOT USED WITH RETURN PUMP)	2.00" NPT, FEMALE
D	ENGINE RETURN PORT	1.00" NPT, FEMALE
E	EXTRA PIPE FLANGE	1.00" NPT, FEMALE
F	TANK VENT PORT	2.00" NPT, FEMALE
G	MANUAL FILL DROP TUBE	2.00" NPT, MALE
H	HAND PUMP DROP TUBE	0.75" NPT, MALE
J	PUMP CONNECTION TO TANK	0.75" NPT, MALE
K	FLOATSWITCH MOUNTING PORT	1.00" NPT, FEMALE
L	CONTAINMENT DRAIN	0.375" NPT, FEMALE
M	LEAK SENSOR PORT	1.00" NPT, FEMALE
N	SECONDARY CONTAINMENT EMERGENCY VENT	4.00" NPT, FEMALE

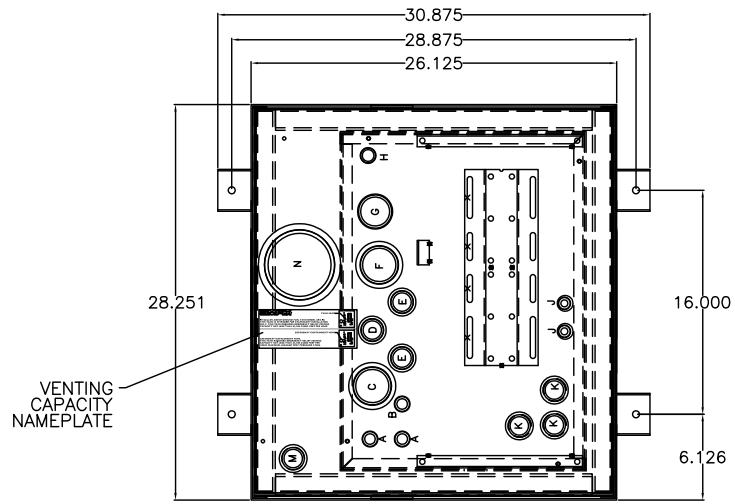

- OPTIONS INSTALLED**
- X002-DELETION OF STD PUMP & MOTOR
 - 015-MANUAL HAND PUMP
 - 025-MANUAL FILL PIPE W/LOCKABLE CAP
 - 060-FUEL STRAINER, Y-TYPE
 - 061-FUEL STRAINER, Y-TYPE, 1.0" NPT, 40 MESH
 - 064-EMERGENCY VENT CAP, 4.00"NPT., 2.5 P.S.I.
 - 065-TANK DRAIN BALL VALVE
 - 066-SIPHON DRAIN PIPING ASSEMBLY
 - 070-PRIMING TEE & CHECK VALVE ASSEMBLY
 - 080-SOLENOID VALVE, N.C. 115VAC
 - 087-MANUAL SHUT-OFF BALL VALVE
 - 088-MANUAL SHUT-OFF BALL VALVE 1.00"NPT
 - 101-VACUUM GAUGE
 - 190-SECONDARY CONTAINMENT, CLOSED TOP
 - 191-FLOATSWITCH IN SECONDARY CONTAINMENT
 - 192-SECONDARY CONTAINMENT DRAIN BALL VALVE

- OPTIONS INSTALLED**
- 120-EXTRA 1.00" PIPE CONNECTION
 - 125-EXTRA ENGINE SUCTION STANDPIPE
 - 270-POWER AVAILABLE PILOT LIGHT
 - 280-PUMP RUN-OFF-AUTO SWITCH
 - 311-LOW FUEL LEVEL ALARM
 - 312-HIGH FUEL LEVEL ALARM
 - 325-HIGH FUEL LEVEL PUMP STOP
 - 333-CRITICAL LOW LEVEL ALARM-ENGINE SHUT DOWN
 - 340-PUMP RUNNING LIGHT
 - 345-DUPLEX PUMP CONTROLLER
 - 390-RETURN PUMP & CONTROLLER
 - HIGH TOP USED W/ SINGLE PUMP 3/4 H.P. OR DUPLEX PUMPS/MOTORS

- OPTIONS SHIPPED LOOSE**
- 050-PIPE STAND ADAPTER BASE
 - 063-VENT CAP
 - 087-MANUAL SHUT-OFF BALL VALVE .50"NPT
 - 090-FOOT VALVE 1.00" NPT
 - 093-FUSIBLE LINK VALVE 1.50" NPT
 - 110-RELOCATION OF STD PUMP & MOTOR
 - 377-ANTI-SIPHON SOLENOID VALVE, N.O. 120VAC

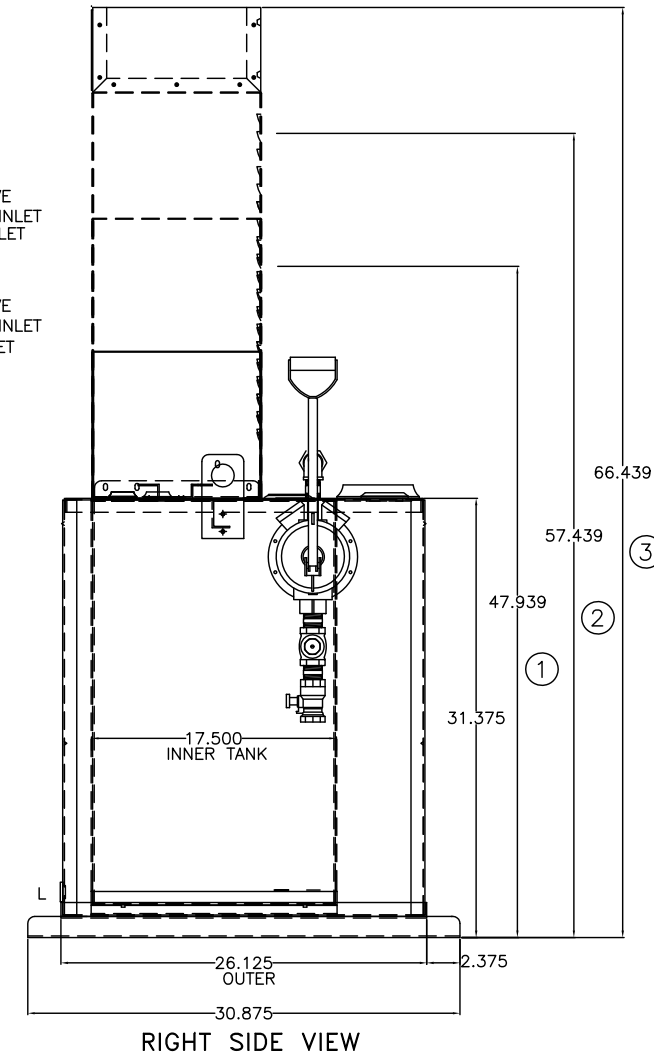
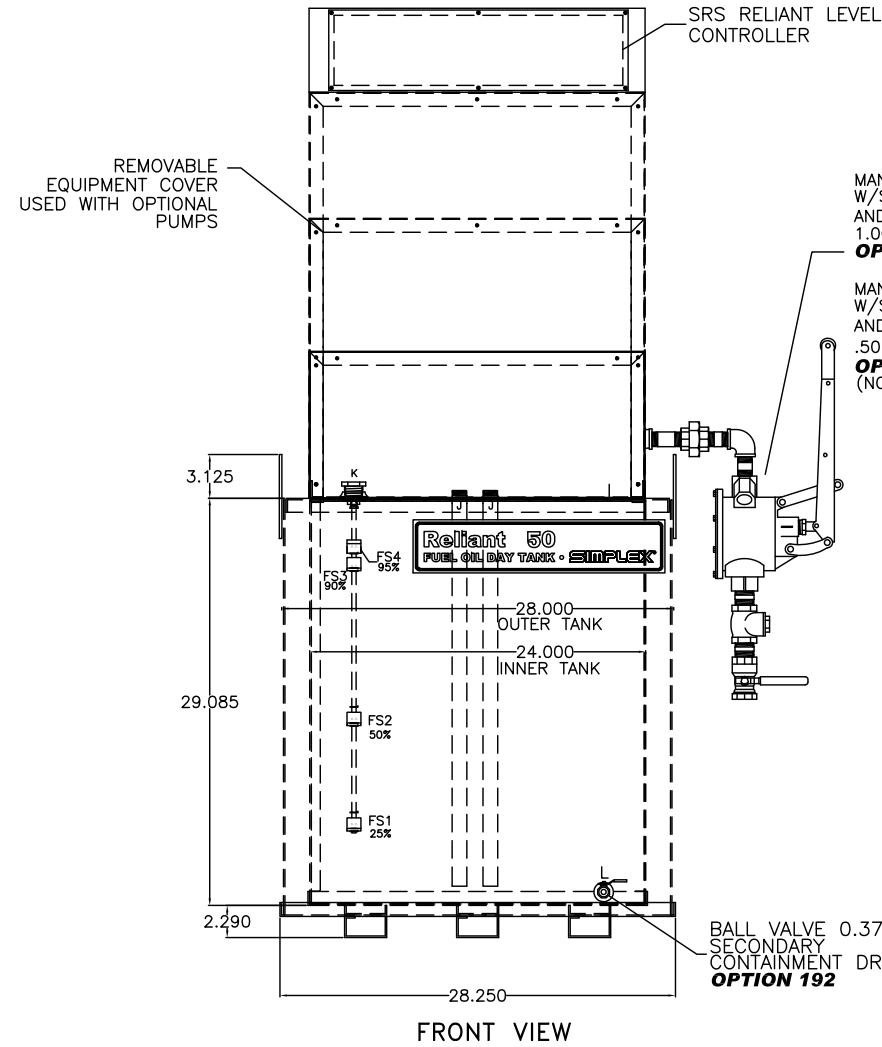
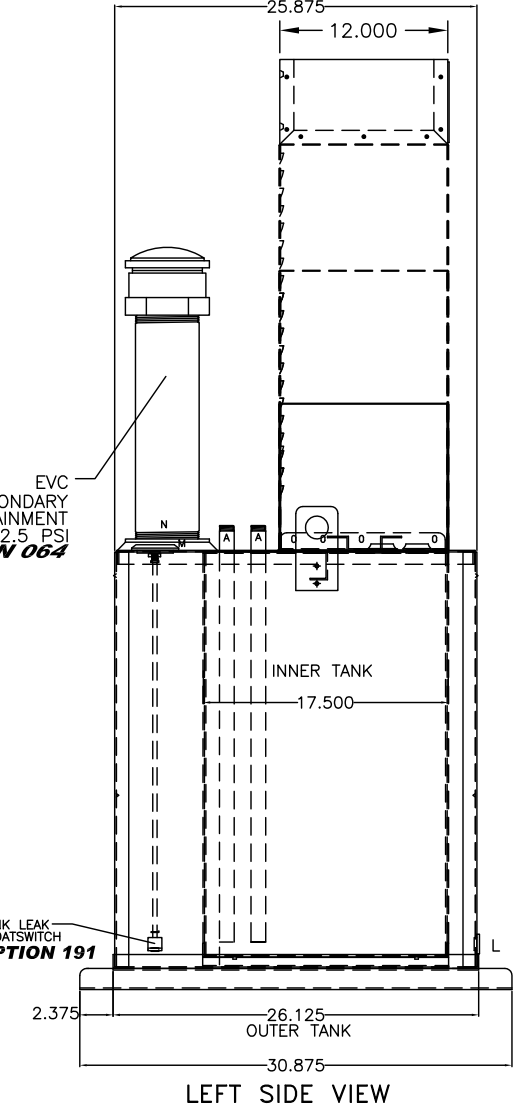
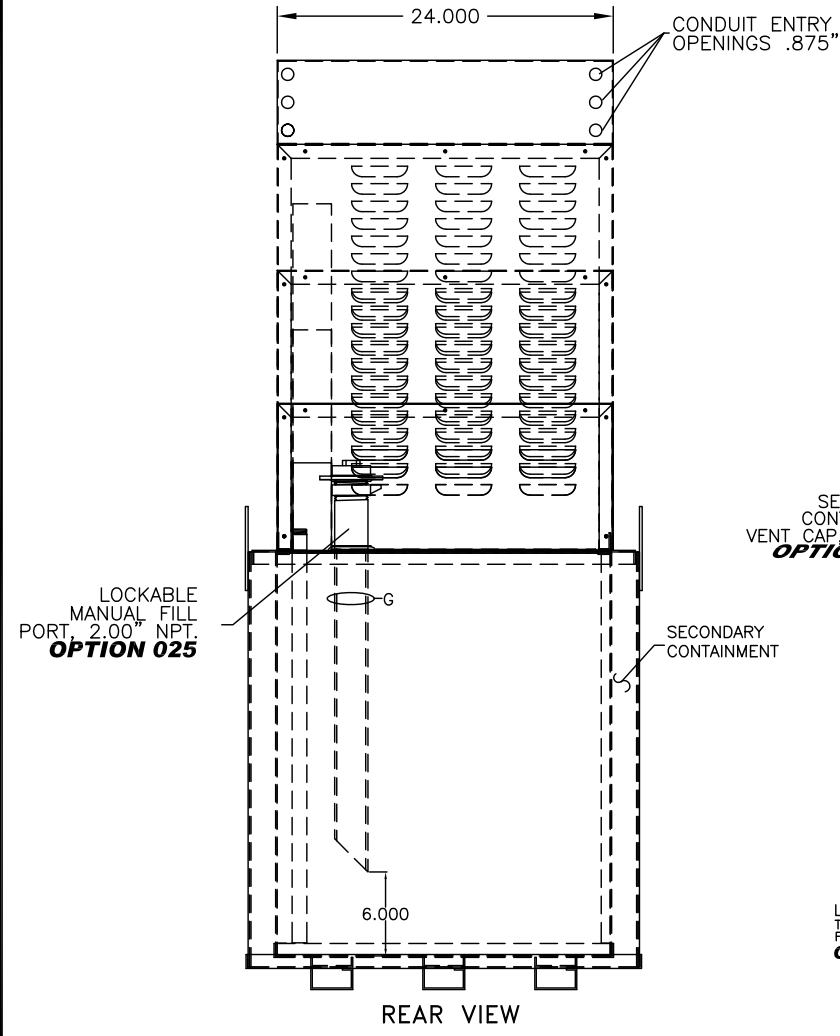
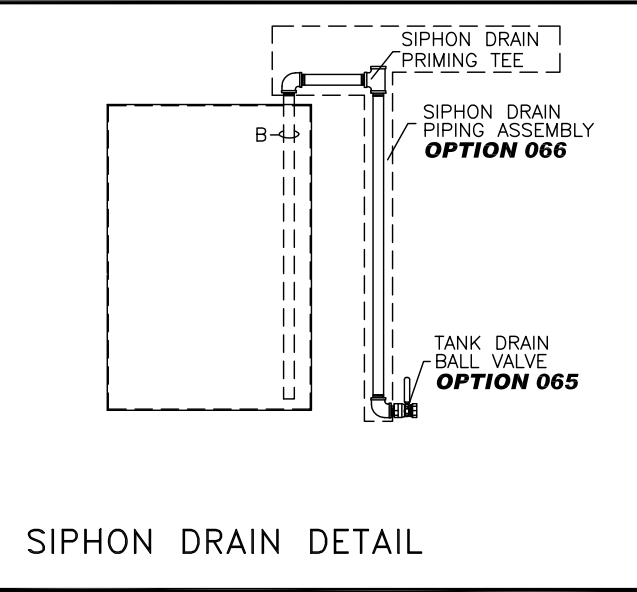

DAY TANK SHOWN WITH STANDARD CONTROL SECTION AND OPTIONAL DUPLEX PUMP/LARGE PUMP SECTION SEE TANK HEIGHT DETAIL.

- NOTES:**
- CONSTRUCTION: 12 GA. H.R.S.
 - LISTING: UL 142**
 - RATING: ATMOSPHERIC TANK TESTED TO 3 PSI
 - FINISH: TANK POWDER COATED BONE WHITE
EQUIPMENT COVER POWDER COATED BONE WHITE
 - DUE TO SYSTEM COMPLEXITY, SOME COMPONENTS MAY NOT BE VISIBLE IN ALL VIEWS
 - ALL DIMENSIONS ±.125"

THE INFORMATION HEREON IS THE PROPERTY OF SIMPLEX, INC., AND/OR ITS SUBSIDIARIES. WITHOUT WRITTEN PERMISSION ANY COPYING, TRANSMITTAL TO OTHERS AND USE EXCEPT THAT FOR WHICH IT IS LOANED IS PROHIBITED. DESIGN SUBJECT TO CHANGE WITHOUT NOTICE. ©2010 SIMPLEX, INC. ALL RIGHTS RESERVED.

SIMPLEX		SPRINGFIELD, ILLINOIS
SCALE :	APPROVED BY :	DRAWN BY : RER
DATE : 08-10-10		REVISED :
RELIANT 50 FUEL OIL DAY TANK PICTORIAL		
STANDARD	DRAWING NUMBER 211964	