

TANK FITTING SCHEDULE

PORT	DESCRIPTION	
A	ENGINE SUPPLY DROP TUBE	0.75" NPT, MALE
B	SIPHON DRAIN DROP TUBE	0.75" NPT, MALE
C	TANK OVERFLOW PORT (NOT USED WITH RETURN PUMP)	2.00" NPT, FEMALE
D	ENGINE RETURN PORT	1.00" NPT, FEMALE
E	EXTRA PIPE FLANGE	1.00" NPT, FEMALE
F	TANK VENT PORT	2.00" NPT, FEMALE
G	MANUAL FILL DROP TUBE	2.00" NPT, MALE
H	HAND PUMP DROP TUBE	0.75" NPT, MALE
J	PUMP CONNECTION TO TANK	0.75" NPT, MALE
K	FLOATSWITCH MOUNTING PORT	1.00" NPT, FEMALE
L	CONTAINMENT DRAIN	0.375" NPT, FEMALE
M	LEAK SENSOR PORT	1.00" NPT, FEMALE
N	SECONDARY CONTAINMENT EMERGENCY VENT	4.00" NPT, FEMALE

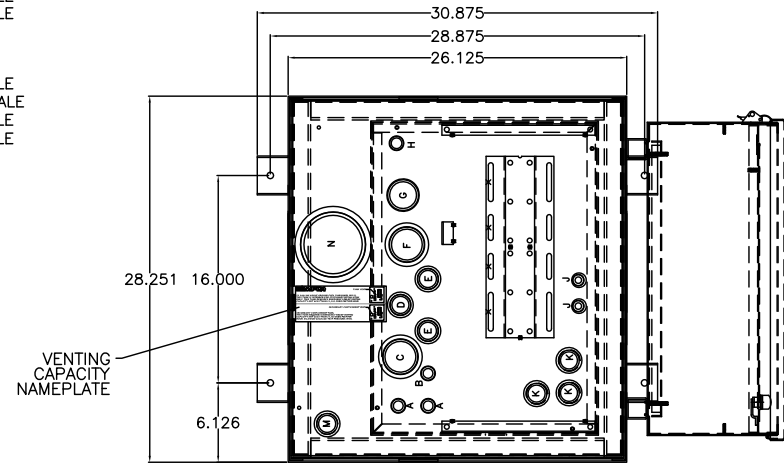

OPTIONS INSTALLED

- X002-DELETION OF STD PUMP & MOTOR
- 015-MANUAL HAND PUMP
- 025-MANUAL FILL PIPE W/LOCKABLE CAP
- 060-FUEL STRAINER, Y-TYPE
- 061-FUEL STRAINER, Y-TYPE, 1.0" NPT, 40 MESH
- 064-EMERGENCY VENT CAP, 4.00"NPT., 2.5 P.S.I.
- 065-TANK DRAIN BALL VALVE
- 066-SIPHON DRAIN PIPING ASSEMBLY
- 070-PRIMING TEE & CHECK VALVE ASSEMBLY
- 080-SOLENOID VALVE, N.C. 115VAC
- 087-MANUAL SHUT-OFF BALL VALVE
- 088-MANUAL SHUT-OFF BALL VALVE 1.00"NPT
- 101-VACUUM GAUGE
- 190-SECONDARY CONTAINMENT, CLOSED TOP
- 191-FLOATSWITCH IN SECONDARY CONTAINMENT
- 192-SECONDARY CONTAINMENT DRAIN BALL VALVE

OPTIONS INSTALLED

- 120- EXTRA 1.00" PIPE CONNECTION
- 125- EXTRA ENGINE SUCTION STANDPIPE
- 270- POWER AVAILABLE PILOT LIGHT
- 280- PUMP RUN-OFF-AUTO SWITCH
- 311-LOW FUEL LEVEL ALARM
- 312-HIGH FUEL LEVEL ALARM
- 325-HIGH FUEL LEVEL PUMP STOP
- 333-CRITICAL LOW LEVEL ALARM-ENGINE SHUT DOWN
- 340- PUMP RUNNING LIGHT
- 345- DUPLEX PUMP CONTROLLER
- 390-RETURN PUMP & CONTROLLER
- HIGH TOP USED W/ SINGLE PUMP 3/4 H.P. OR DUPLEX PUMPS/MOTORS

OPTIONS SHIPPED LOOSE

- 050- PIPE STAND ADAPTER BASE
- 063- VENT CAP
- 087- MANUAL SHUT-OFF BALL VALVE .50"NPT
- 090- FOOT VALVE 1.00" NPT
- 093- FUSIBLE LINK VALVE 1.50" NPT
- 110-RELOCATION OF STD PUMP & MOTOR
- 377- ANTI-SIPHON SOLENOID VALVE, N.O. 120VAC

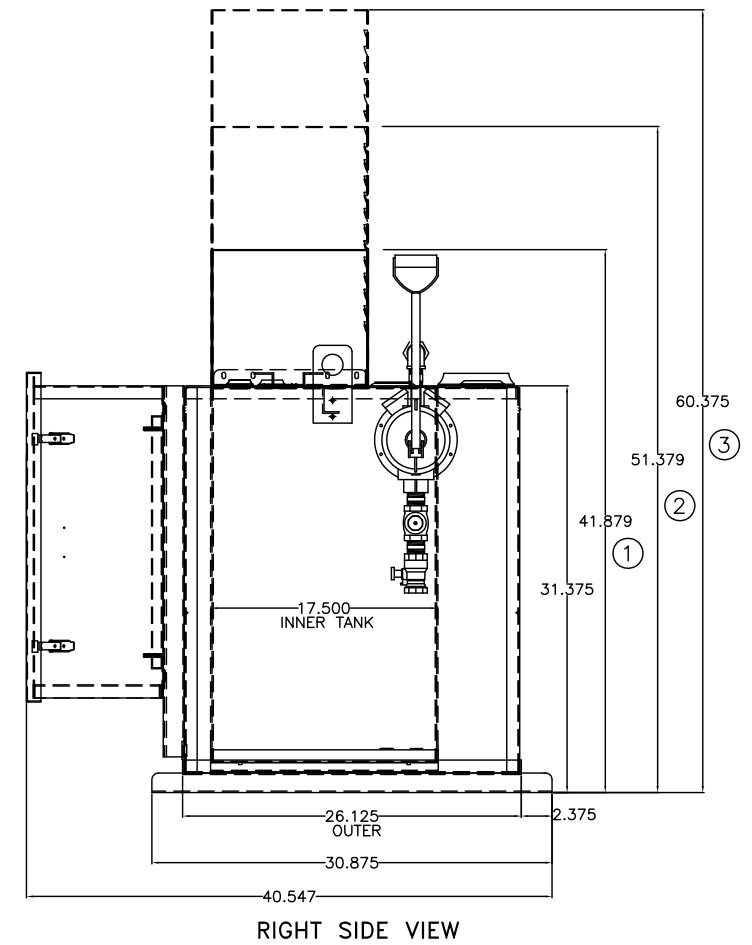
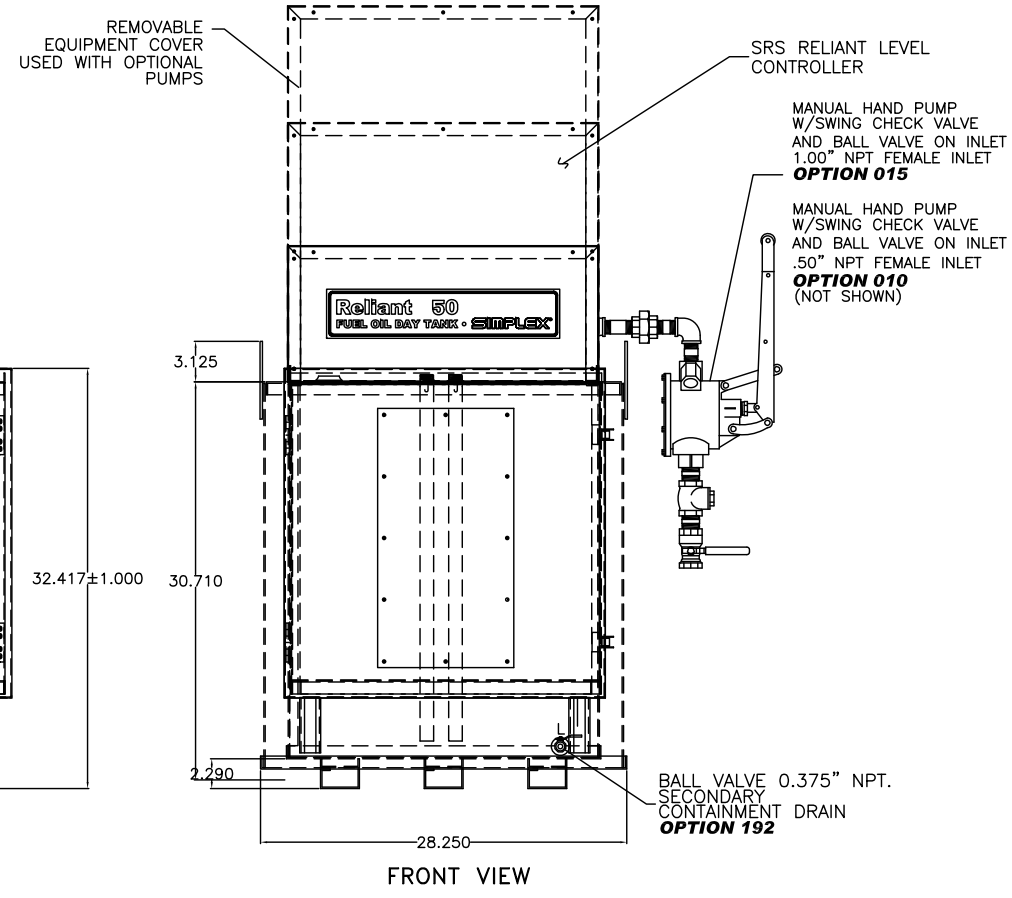
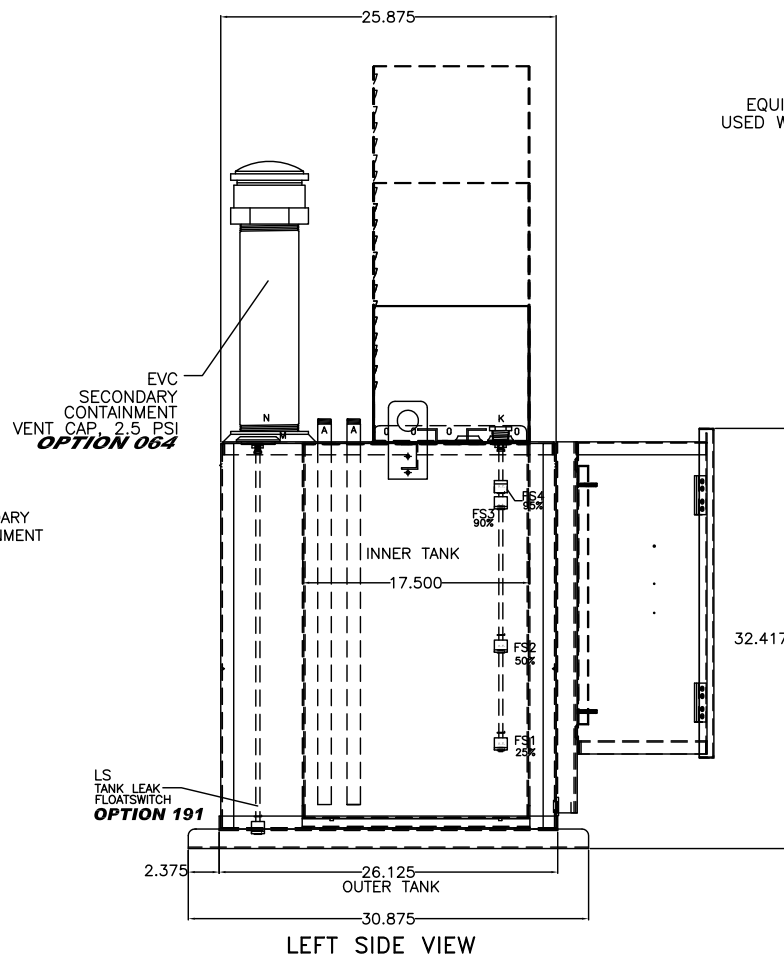
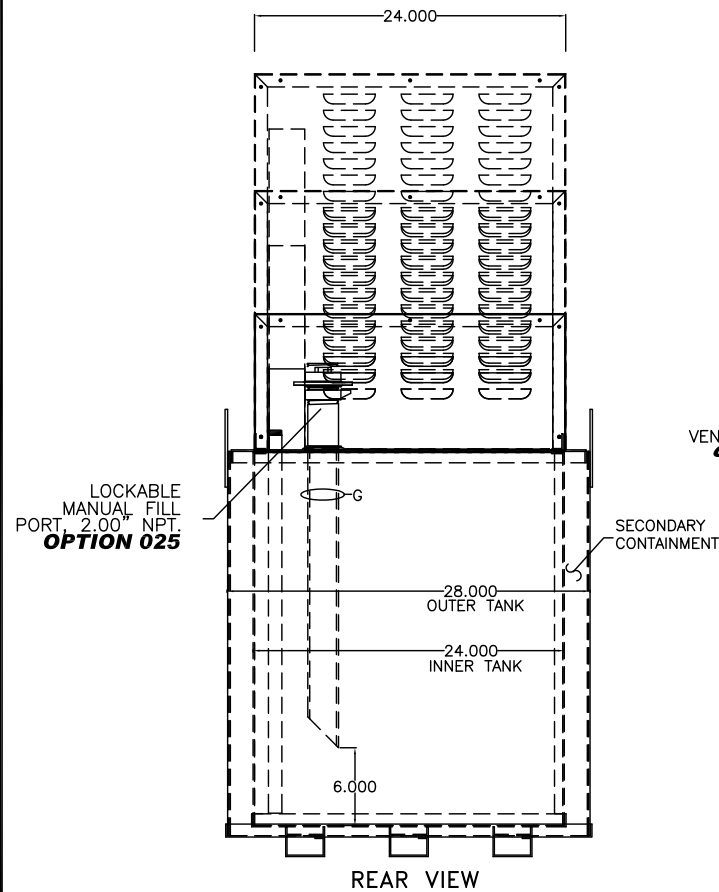
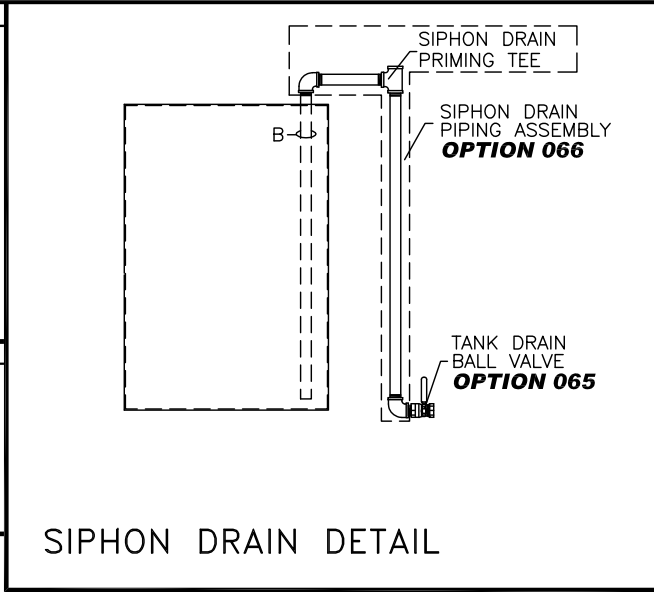

DAY TANK SHOWN WITH STANDARD CONTROL SECTION AND OPTIONAL DUPLEX PUMP/LARGE PUMP SECTION SEE TANK HEIGHT DETAIL.

- NOTES:**
- CONSTRUCTION: 12 GA. H.R.S.
 - LISTING: UL 142**
 - RATING: ATMOSPHERIC TANK TESTED TO 3 PSI
 - FINISH: TANK POWDER COATED BONE WHITE
EQUIPMENT COVER POWDER COATED BONE WHITE
 - DUE TO SYSTEM COMPLEXITY, SOME COMPONENTS MAY NOT BE VISIBLE IN ALL VIEWS
 - ALL DIMENSIONS ±.125"

THE INFORMATION HEREON IS THE PROPERTY OF SIMPLEX, INC., AND/OR ITS SUBSIDIARIES. WITHOUT WRITTEN PERMISSION ANY COPYING, TRANSMITTAL TO OTHERS AND USE EXCEPT THAT FOR WHICH IT IS LOANED IS PROHIBITED. DESIGN SUBJECT TO CHANGE WITHOUT NOTICE. ©2010 SIMPLEX, INC. ALL RIGHTS RESERVED.

SIMPLEX SPRINGFIELD, ILLINOIS

SCALE :	APPROVED BY :	DRAWN BY : RER
DATE : 08-10-10		REVISED :
RELIANT 50 FUEL OIL DAY TANK PICTORIAL WITH SIDE BOX		
STANDARD	DRAWING NUMBER 211965	