

TANK FITTING SCHEDULE		
PORT	DESCRIPTION	SIZE
A	ENGINE SUPPLY DROP TUBE	0.75" NPT, MALE
B	SIPHON DRAIN DROP TUBE	0.75" NPT, MALE
C	TANK OVERFLOW PORT (NOT USED WITH RETURN PUMP)	2.00" NPT, FEMALE
D	ENGINE RETURN PORT	1.00" NPT, FEMALE
E	EXTRA PIPE FLANGE	1.00" NPT, FEMALE
F	TANK VENT PORT	2.00" NPT, FEMALE
G	MANUAL FILL DROP TUBE	2.00" NPT, MALE
H	HAND PUMP DROP TUBE	0.75" NPT, MALE
J	PUMP CONNECTION TO TANK DROP TUBE	0.75" NPT, MALE
K	FLOATSWITCH MTG/INSPECTION PORT	1.00" NPT, FEMALE
L	SECONDARY CONTAINMENT EMERGENCY VENT	4.00" NPT, FEMALE
M	TANK LEAK SENSOR PORT	1.00" NPT, FEMALE
P	RUPTURE BASIN DRAIN	.375" NPT, FEMALE

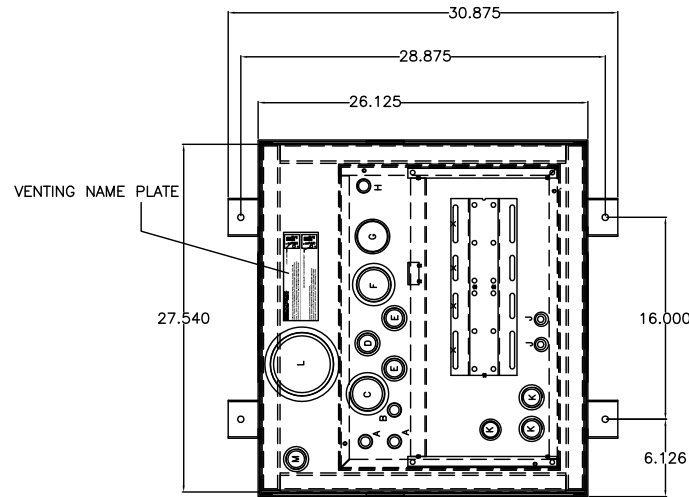

- OPTIONS INSTALLED**
- X002-DELETION OF STD PUMP & MOTOR
  - 015-MANUAL HAND PUMP
  - 025-MANUAL FILL PIPE W/LOCKABLE CAP
  - 060-FUEL STRAINER, Y-TYPE
  - 061-FUEL STRAINER, Y-TYPE, 1.0" NPT, 40 MESH
  - 064-EMERGENCY VENT CAP, 4.00"NPT., 2.5 P.S.I.
  - 065-TANK DRAIN BALL VALVE
  - 066-SIPHON DRAIN PIPING ASSEMBLY
  - 070-PRIMING TEE & CHECK VALVE ASSEMBLY
  - 080-SOLENOID VALVE, N.C. 115VAC
  - 087-MANUAL SHUT-OFF BALL VALVE
  - 088-MANUAL SHUT-OFF BALL VALVE 1.00"NPT
  - 101-VACUUM GAUGE
  - 190-SECONDARY CONTAINMENT, CLOSED TOP
  - 191-FLOATSWITCH IN SECONDARY CONTAINMENT
  - 192-SECONDARY CONTAINMENT DRAIN BALL VALVE

- OPTIONS INSTALLED**
- 120-EXTRA 1.00" PIPE CONNECTION
  - 125-EXTRA ENGINE SUCTION STANDPIPE
  - 270-POWER AVAILABLE PILOT LIGHT
  - 280-PUMP RUN-OFF-AUTO SWITCH
  - 311-LOW FUEL LEVEL ALARM
  - 312-HIGH FUEL LEVEL ALARM
  - 325-HIGH FUEL LEVEL PUMP STOP
  - 333-CRITICAL LOW LEVEL ALARM-ENGINE SHUT DOWN
  - 340-PUMP RUNNING LIGHT
  - 345-DUPLEX PUMP & CONTROLLER
  - 390-RETURN PUMP & CONTROLLER
  - HIGH TOP USED W/ SINGLE PUMP 3/4 H.P. OR DUPLEX PUMPS/MOTORS

- OPTIONS SHIPPED LOOSE**
- 050-PIPE STAND ADAPTER BASE
  - 063-VENT CAP
  - 087-MANUAL SHUT-OFF BALL VALVE .50"NPT
  - 090-FOOT VALVE 1.00" NPT
  - 093-FUSIBLE LINK VALVE 1.50" NPT
  - 110-RELOCATION OF STD PUMP & MOTOR
  - 377-ANTI-SIPHON SOLENOID VALVE, N.O. 120VAC

DAY TANK SHOWN WITH STANDARD CONTROL SECTION AND OPTIONAL DUPLEX PUMP/LARGE PUMP SECTION SEE TANK HEIGHT.

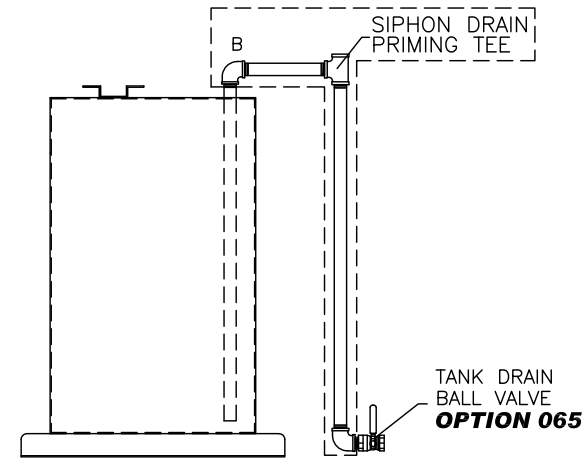

SIPHON DRAIN DETAIL

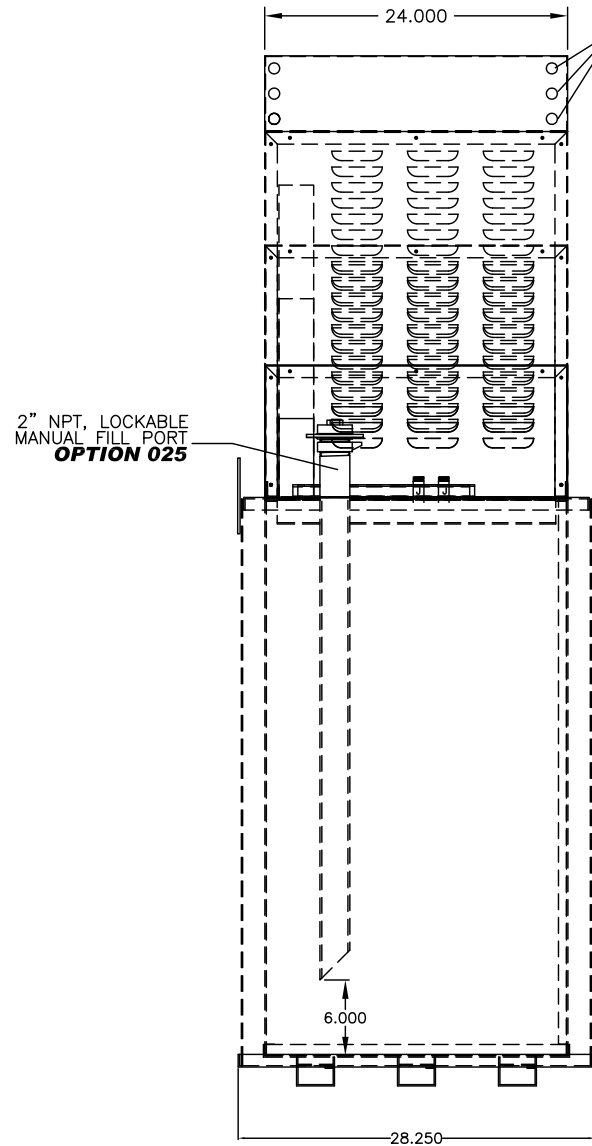

REAR VIEW

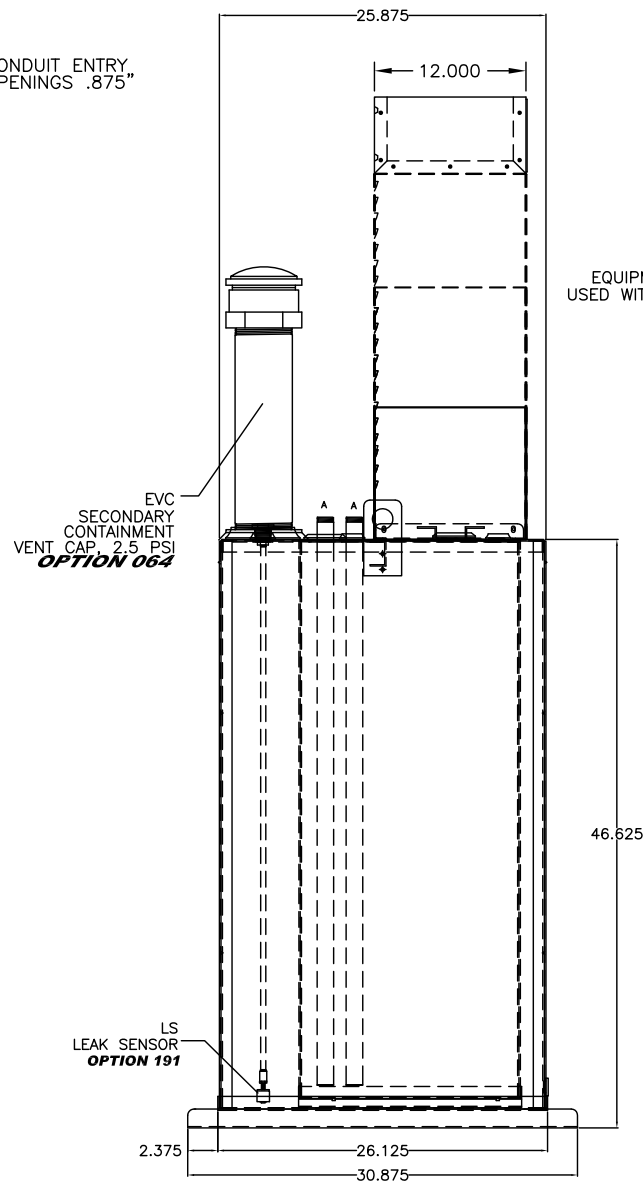

L.H. VIEW

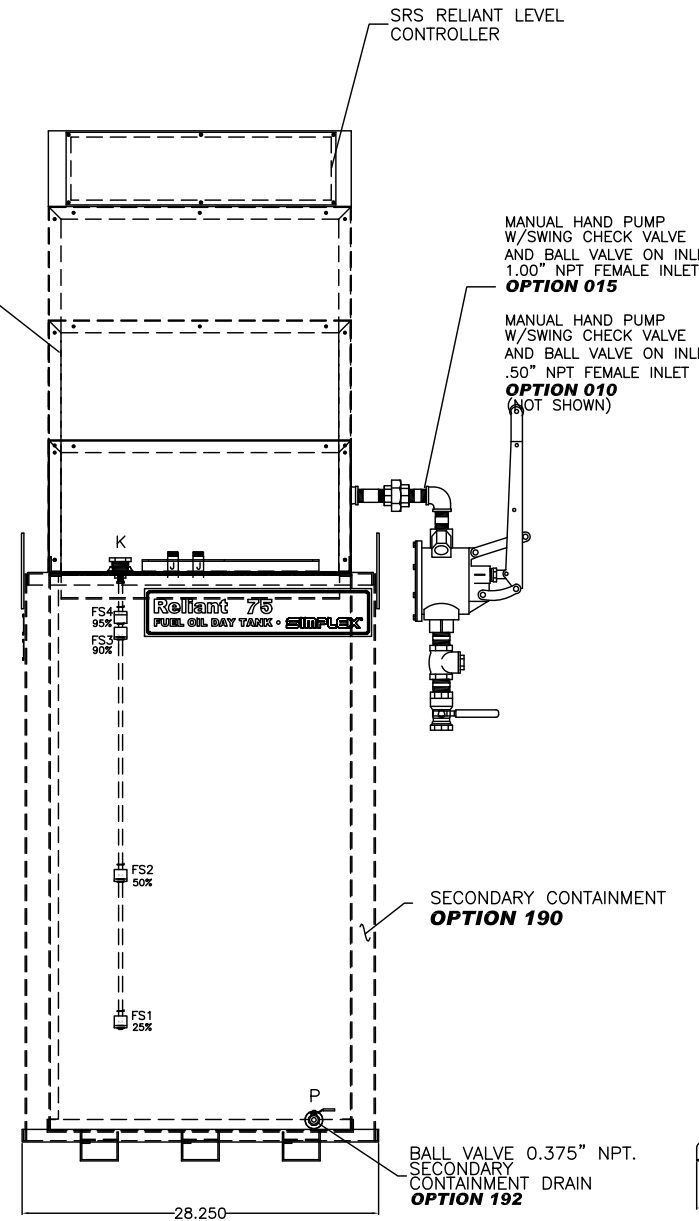

FRONT VIEW

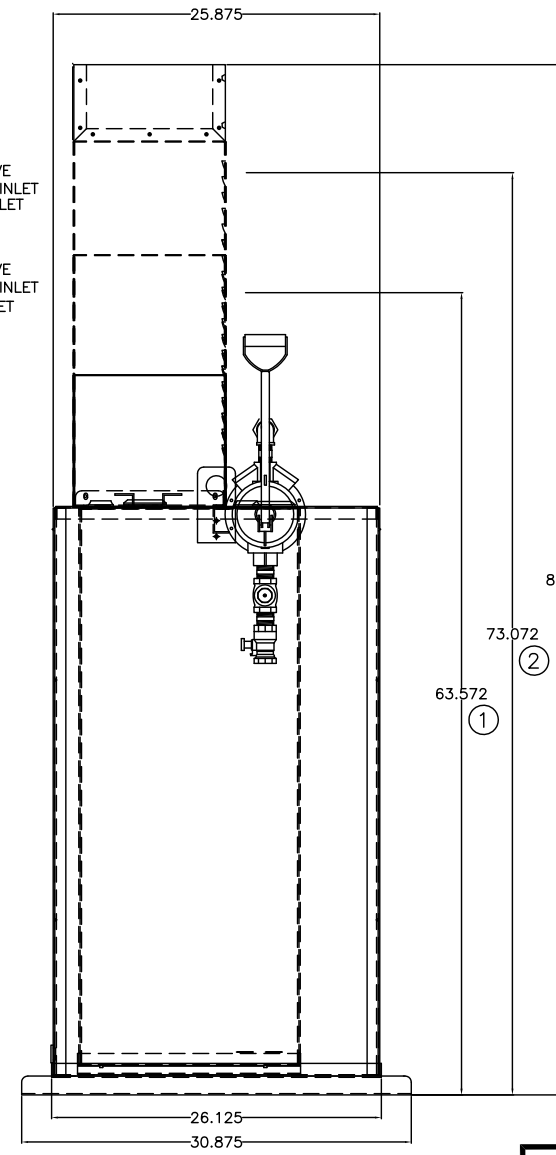

**NOTES:**

- 1) CONSTRUCTION: 12 GA. H.R.S.
- 2) LISTING: UL 142
- 3) RATING: ATMOSPHERIC TANK TESTED TO 3 PSI
- 4) FINISH: TANK POWDER COATED BONE WHITE  
EQUIPMENT COVER POWDER COATED BONE WHITE
- 5) DUE TO SYSTEM COMPLEXITY, SOME COMPONENTS MAY NOT BE VISIBLE IN ALL VIEWS
- 6) ALL DIMENSIONS ±.125"

<b>SIMPLEX</b>		SPRINGFIELD, ILLINOIS
SCALE :	APPROVED BY :	DRAWN BY : RER
DATE : 08-10-10		REVISED :
RELIANT 75 FUEL OIL DAY TANK PICTORIAL		
STANDARD	DRAWING NUMBER 211966	

THE INFORMATION HEREON IS THE PROPERTY OF SIMPLEX, INC., AND/OR ITS SUBSIDIARIES. WITHOUT WRITTEN PERMISSION ANY COPYING, TRANSMITTAL TO OTHERS AND USE EXCEPT THAT FOR WHICH IT IS LOANED IS PROHIBITED. DESIGN SUBJECT TO CHANGE WITHOUT NOTICE. ©2010 SIMPLEX, INC. ALL RIGHTS RESERVED.