

VENTING: INSTALL EMERGENCY VENT CAP AT PORT 'L', ELEVATE 6.00"  
 PLUMB WORKING VENT FROM PORT 'F' TO OUTDOORS  
 INSTALL CAP AT OUTDOOR TERMINATION

**TANK FITTING SCHEDULE**

PORT	DESCRIPTION	SIZE
A	ENGINE SUPPLY DROP TUBE	0.75" NPT, MALE
B	SIPHON DRAIN DROP TUBE	0.75" NPT, MALE
C	OVERFLOW PORT (NOT USED WITH RETURN PUMP)	2.00" NPT, FEMALE
D	ENGINE RETURN PORT	1.00" NPT, FEMALE
E	EXTRA PIPE FLANGE	1.00" NPT, FEMALE
F	TANK VENT PORT	2.00" NPT, FEMALE
G	MANUAL FILL DROP TUBE	2.00" NPT, MALE
H	HAND PUMP MOUNTING DROP TUBE	0.75" NPT, MALE
J	PUMP CONNECTION TO TANK DROP TUBE	0.75" NPT, MALE
K	FLOATSWITCH MTG/INSPECTION PORT	1.00" NPT, FEMALE
L	TANK EMERGENCY VENT	4.00" NPT, FEMALE
M	SECONDARY CONTAINMENT DRAIN	0.375" NPT, FEMALE
R	CONTAINMENT LEAK SENSOR PORT	1.00" NPT, FEMALE
S	SECONDARY CONTAINMENT EMERGENCY VENT	4.00" NPT, FEMALE

DAY TANK SHOWN WITH STANDARD CONTROL SECTION  
 AND OPTIONAL DUPLEX PUMP/LARGE PUMP SECTION  
 SEE TANK HEIGHT DETAIL.

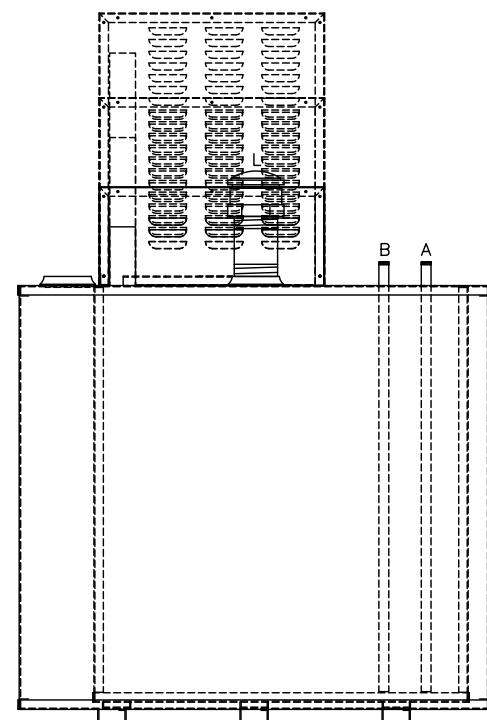
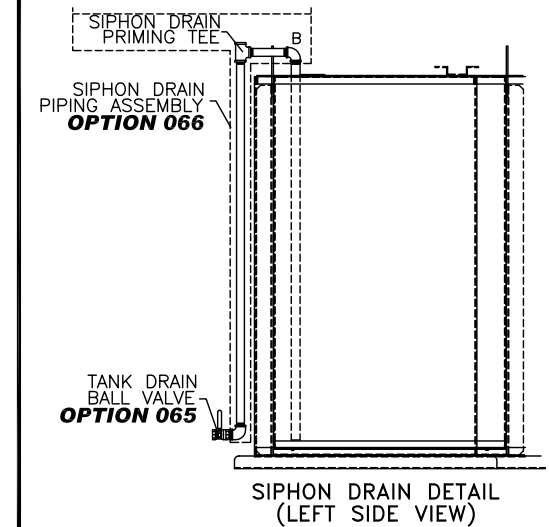
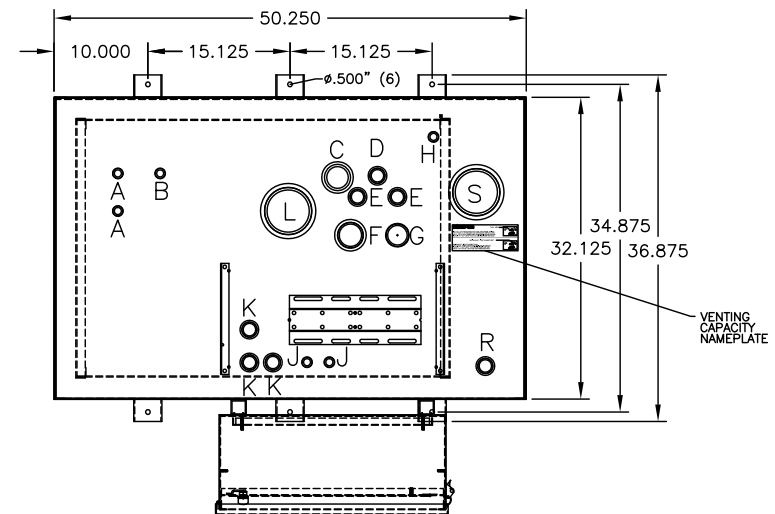

REAR VIEW

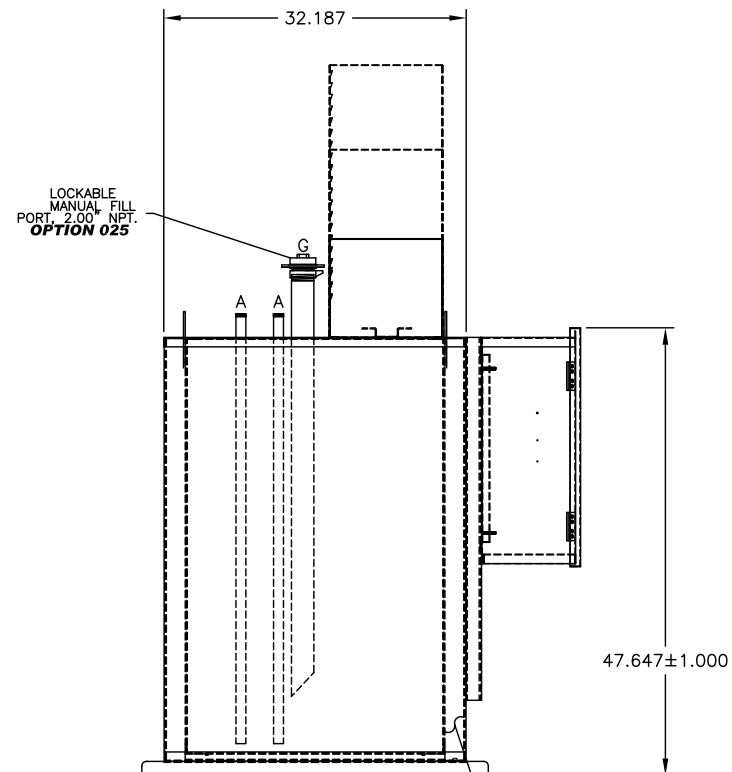

LEFT SIDE VIEW

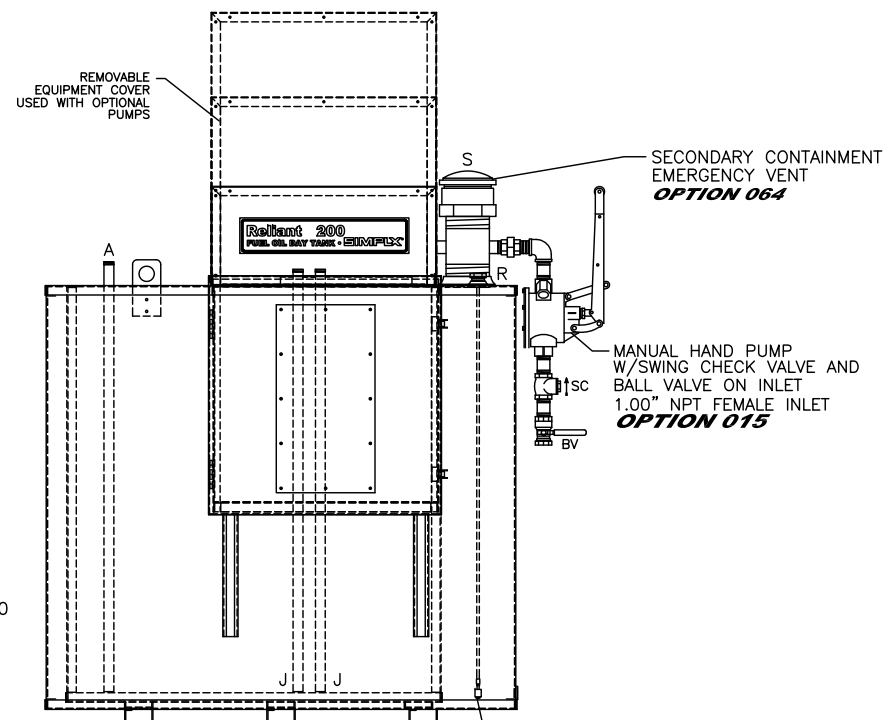

FRONT VIEW

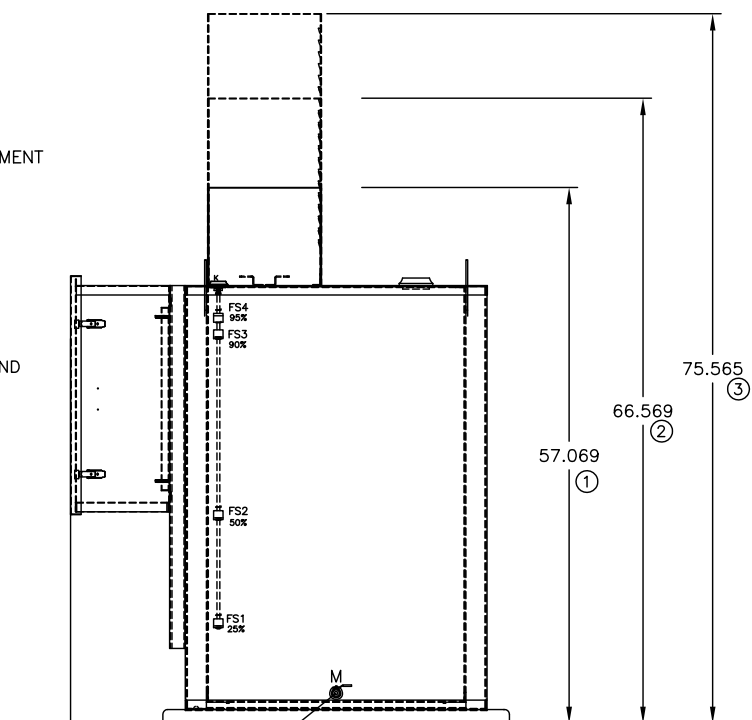

RIGHT SIDE VIEW

THE INFORMATION HEREON IS THE PROPERTY OF SIMPLEX, INC., AND/OR ITS SUBSIDIARIES. WITHOUT WRITTEN PERMISSION ANY COPYING, TRANSMITTAL TO OTHERS AND USE EXCEPT THAT FOR WHICH IT IS LOANED IS PROHIBITED. DESIGN SUBJECT TO CHANGE WITHOUT NOTICE.  
 ©2010 SIMPLEX, INC. ALL RIGHTS RESERVED.

OPTIONS INSTALLED	OPTIONS INSTALLED	OPTIONS SHIPPED LOOSE
<input type="checkbox"/> X002-DELETION OF STD PUMP & MOTOR	<input type="checkbox"/> 125-EXTRA ENGINE SUCTION DROP TUBE	<input type="checkbox"/> 060- FUEL STRAINER .75" NPT, 40 MESH
<input type="checkbox"/> 010-MANUAL HAND PUMP	<input type="checkbox"/> 191-FLOATSWITCH IN CONTAINMENT	<input type="checkbox"/> 060- FUEL STRAINER 1.00" NPT, 40 MESH
<input type="checkbox"/> 015-MANUAL HAND PUMP	<input type="checkbox"/> 192-CONTAINMENT DRAIN BALL VALVE	<input type="checkbox"/> 063- VENT CAP, 2.00" NPT
<input type="checkbox"/> 025-MANUAL FILL PIPE W/LOCKABLE CAP	<input type="checkbox"/> 261-INTERNAL CIRCUIT BREAKER	<input type="checkbox"/> 080-SOLENOID VALVE, N.C. 120VAC
<input type="checkbox"/> 064-EMERGENCY TANK VENT 4.00" NPT	<input type="checkbox"/> 345- DUPLEX PUMP CONTROLLER	<input type="checkbox"/> 087- MANUAL SHUT-OFF BALL VALVE .50"NPT
<input type="checkbox"/> 065-TANK DRAIN BALL VALVE	<input type="checkbox"/> 390-OVERFLOW RETURN PUMP & CONTROLLER	<input type="checkbox"/> 087- MANUAL SHUT-OFF BALL VALVE .75"NPT
<input type="checkbox"/> 066-SIPHON DRAIN PIPING ASSEMBLY	<input type="checkbox"/> HIGH TOP USED W/DUPLEX PUMPS-MOTORS	<input type="checkbox"/> 090- FOOT VALVE 1.00" NPT
<input type="checkbox"/> 070-PRIMING TEE & CHECK VALVE ASSEMBLY		<input type="checkbox"/> 093- FUSIBLE LINK VALVE 1.50" NPT
<input type="checkbox"/> 087- MANUAL SHUT-OFF BALL VALVE 1.00"NPT		
<input type="checkbox"/> 120-EXTRA 1.00" PIPE CONNECTION		

- NOTES:
- 1) CONSTRUCTION: 12 GA. H.R.S.
  - 2) LISTING: UL 142
  - 3) RATING: ATMOSPHERIC TANK TESTED TO 3 PSI
  - 4) FINISH: TANK POWDER COATED BONE WHITE  
EQUIPMENT COVER POWDER COATED BONE WHITE
  - 5) DUE TO SYSTEM COMPLEXITY, SOME COMPONENTS MAY NOT BE VISIBLE IN ALL VIEWS
  - 6) ALL DIMENSIONS ±.125"

**SIMPLEX** SPRINGFIELD, ILLINOIS

SCALE : \_\_\_\_\_ APPROVED BY : \_\_\_\_\_ DRAWN BY : RER

DATE : 08-10-10 \_\_\_\_\_ REVISED : \_\_\_\_\_

RELIANT 200 FUEL OIL DAY TANK PICTORIAL WITH SIDE BOX

STANDARD DRAWING NUMBER 211973