

# GASOLINE

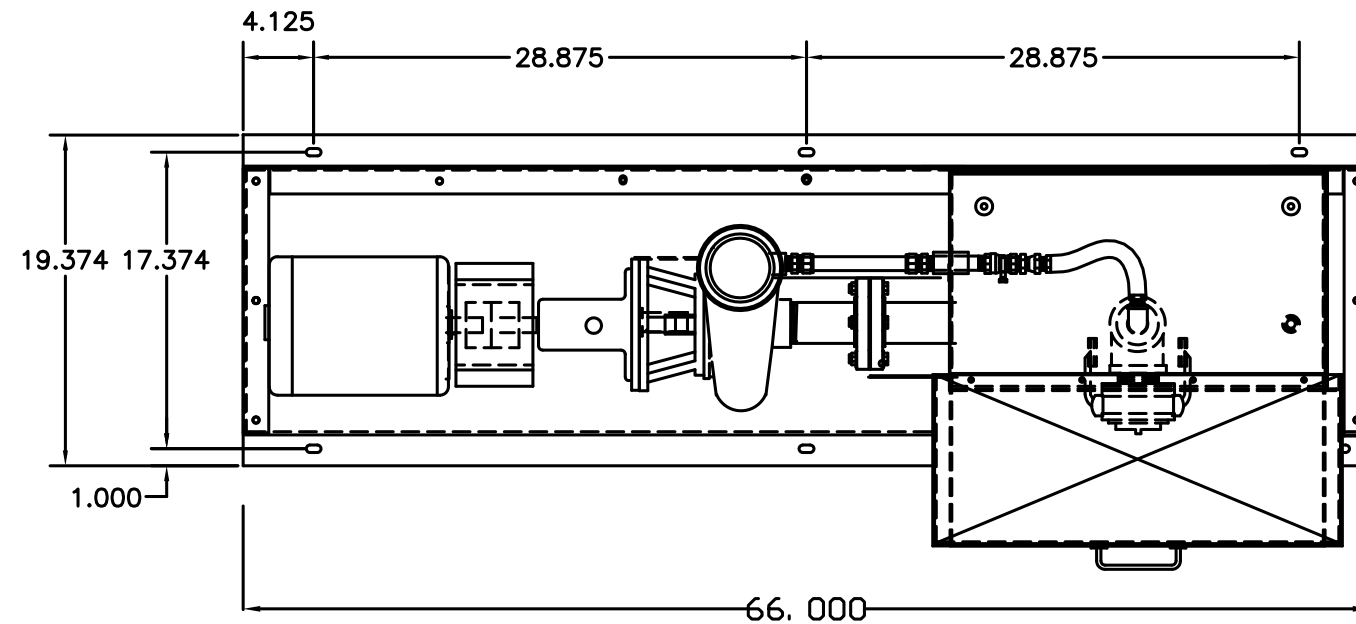

**\* \* WARNING \* \***

1. THIS EQUIPMENT IS SUITABLE FOR USE IN CLASS 1 DIVISION 1, GROUP D, HAZARDOUS LOCATIONS OR NON-HAZARDOUS LOCATIONS ONLY.
2. WARNING - EXPLOSION HAZARD - SUBSTITUTION OF COMPONENTS MAY IMPAIR SUITABILITY FOR DIVISION 1, GROUP D, HAZARDOUS LOCATIONS.
3. WARNING - EXPLOSION HAZARD - DO NOT SERVICE THIS EQUIPMENT UNLESS POWER HAS BEEN TURNED OFF OR THE AREA IS KNOWN TO BE NON-HAZARDOUS
4. EXPLOSION PROOF WIRING, CONDUITS, AND VAPOR SEALING BARRIERS REQUIRED. INSTALL PER APPLICABLE NEC & NFPA REQUIREMENTS FOR HAZARDOUS LOCATIONS

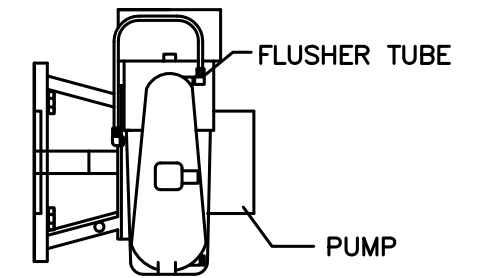

FLUSHER TUBE ASSEMBLY  
DETAIL

**NOTES:**

1. CONSTRUCTION: 12 GA. H.R.S.
2. PAINT: POWDER COAT BONE WHITE
3. DUE TO COMPLEXITY SOME COMPONENTS MAY NOT BE VISIBLE IN ALL VIEWS
4. ALL DIMENSIONS  $\pm .125"$
5. FITTING SIZE: 2", 3" OR 4"

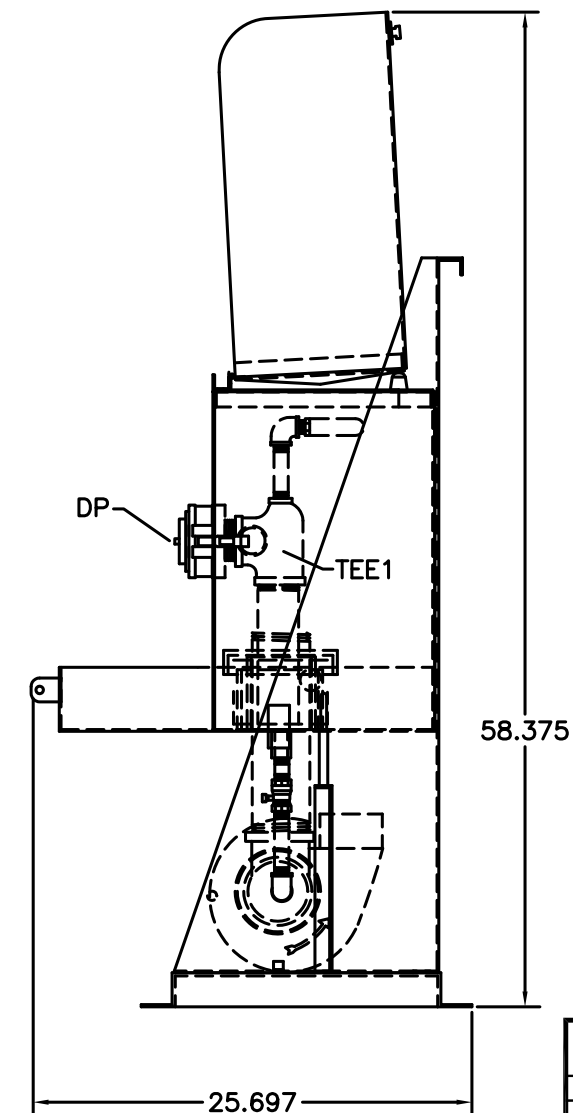
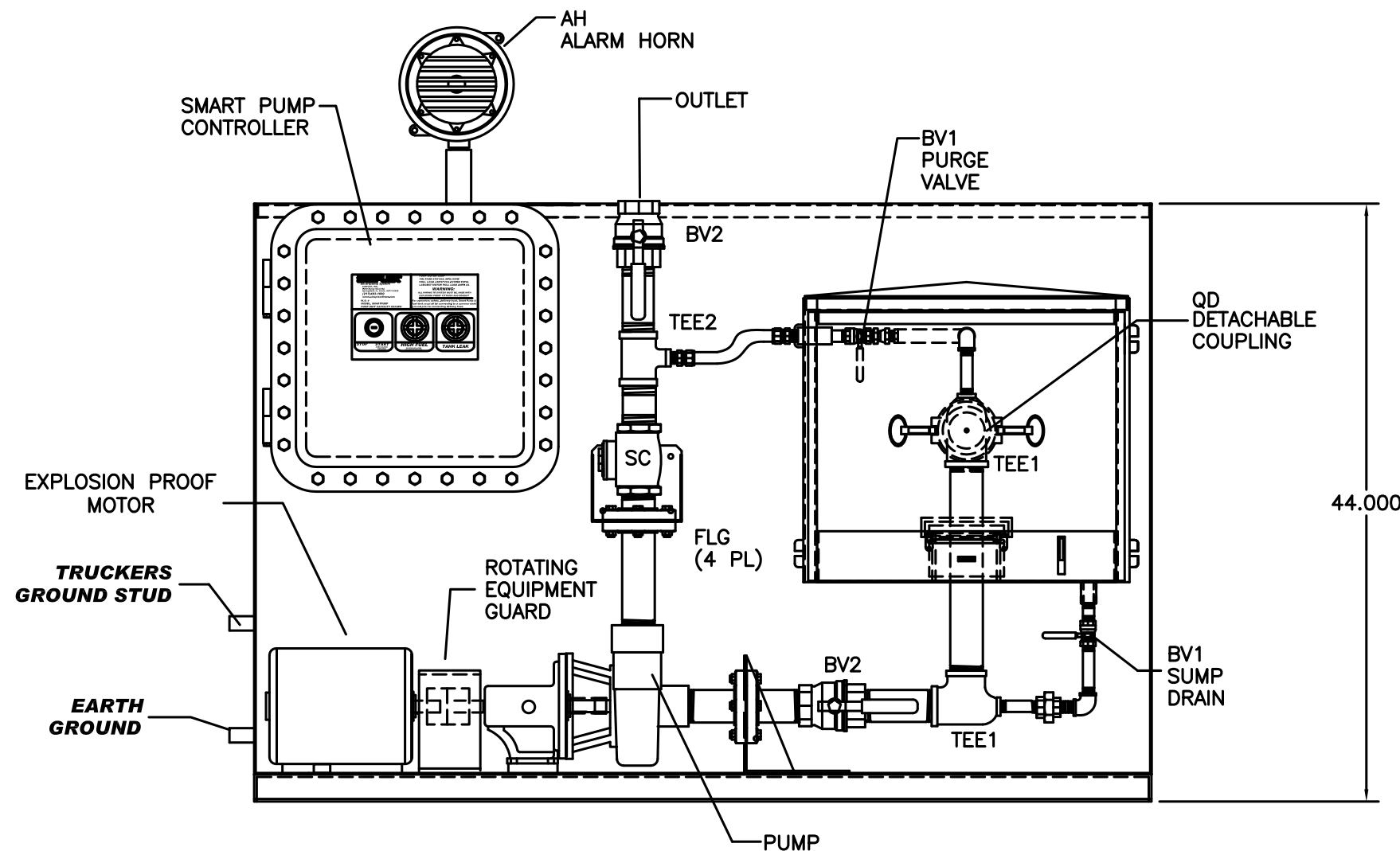

<b>SIMPLEX</b>		SPRINGFIELD, ILLINOIS
SCALE :	APPROVED BY :	DRAWN BY : RER
DATE : 08-10-10		REVISED :
SMARTPUMP-GASOLINE PICTORIAL		
STANDARD		DRAWING NUMBER 211990

THE INFORMATION HEREON IS THE PROPERTY OF SIMPLEX, INC., AND/OR ITS SUBSIDIARIES. WITHOUT WRITTEN PERMISSION ANY COPYING, TRANSMITTAL TO OTHERS AND USE EXCEPT THAT FOR WHICH IT IS LOANED IS PROHIBITED. DESIGN SUBJECT TO CHANGE WITHOUT NOTICE.  
©2010 SIMPLEX, INC. ALL RIGHTS RESERVED.