

ELECTRA DIGITAL LOAD BANK TECHNICAL MANUAL

Customer: XXXXX

Work Order: XXXXX-XX-XX

Model: Electra

June 2011

The information herein is the property of Simplex, Inc. and/or its subsidiaries.
Without written permission, any copying, transmitting to others, and other use
except that for which it is loaned, is prohibited.

(File: Electra-110601.indd)

Contents

- DESCRIPTION 2
 - Control System 3
 - Cooling System 3
 - Load System..... 4

- PRIMARY INSPECTION 4

- LOCATION, SETUP AND CONNECTIONS..... 6

- OPERATION..... 7
 - Shutdown..... 8

- DIAGNOSTICS SCREEN 8

- MAINTENANCE SCREEN 8

- MAINTENANCE 9
 - Each Operation 9
 - Every 50 Hours or 6 Months 9
 - Motor Lubrication 9

- TROUBLESHOOTING 11
 - Cooling Fan Motor Will Not Operate 11
 - Cooling Failure Indicated 11
 - Some Load Steps Cannot Be Energized..... 11
 - Load Over Voltage Indicated 11

- DRAWINGS AND PARTS LIST 12

- APPENDIX A - ABBREVIATIONS USED IN THIS MANUAL..... 13

- APPENDIX B - CALCULATIONS & FORMULAS 14

- APPENDIX C - TORQUE VALUES..... 17

- APPENDIX D - TYPICAL LIFT EYE INSTALLATION 19

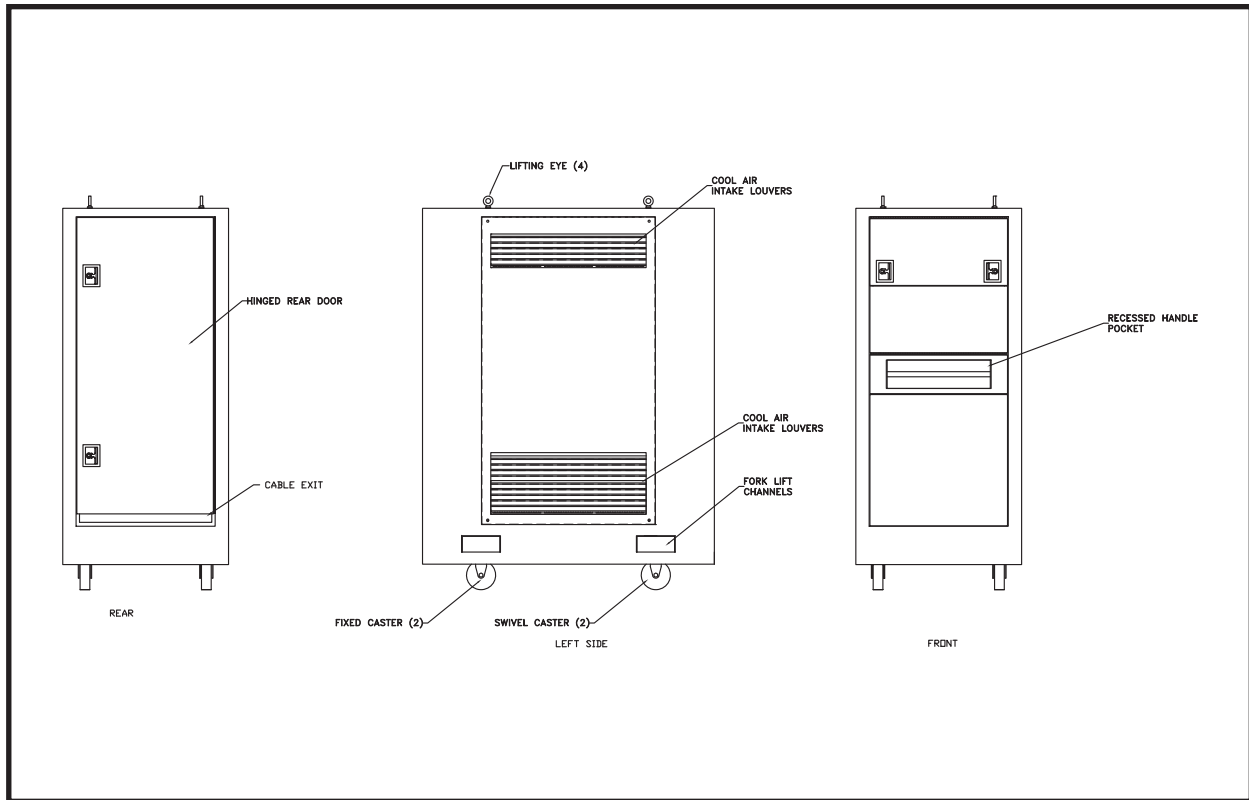

Part of Typical Pictorial Drawing

DESCRIPTION

The Simplex Electra is a very large capacity, high performance Digital Load Bank designed to provide the manufacturers, distributors and users of large AC generators and UPS systems with sophisticated testing capability.

The Electra is a totally self-contained testing system. It includes all resistive load elements, load control devices, load element circuit protective devices, connection cable set, cooling system, malfunction detection system, control power supply and test instrumentation.

This fully self-contained Digital Load Bank includes test instrumentation, connection cables, high-capacity cooling system, rugged load elements, complete load-application control devices, and automatic, system protection

devices. The Load Bank is compact and portable. It includes lifting eyes, forklift channels, and a moving handle. Connection cables are conveniently stored in a cable compartment behind a hinged door. The touchscreen control panel is protected by a hinged panel cover.

Power source testing is accomplished by applying resistive load steps at unity (1.0) power factor. *See the Load Bank Specifications Sheet in the front of this manual for the rating of your Load Bank.*

The illustrations in this manual are examples only and may differ from your Load Bank.

Load application is by magnetic contactor. All load branch circuits are protected by 200,000AIC class-T fuses.

The Load Bank consists of three principal systems:

1. Control System
2. Cooling System
3. Load System

CONTROL SYSTEM

The Load Bank control system is a Programmable Logic Controller (PLC) based system with a touchscreen operator interface. Multiple units may be connected to increase system capacity.

Fan/Control Power is supplied to this Load Bank by inserting the Fan/Control Power Cord Plug into the receptacle at the rear of the Load Bank or into an external receptacle. This receptacle is not current protected and should only be used for the Fan/Control Power Cord Plug.

The control system automatically connects control contactors for applied voltage, detects control power source and voltage, and detects cooling fan motor and motor connection.



WARNING

Always remove all power from the load bus and all fan/control power before servicing the Load Bank. Never operate or service a Load Bank that is not properly connected to an earthground.

COOLING SYSTEM

The Load Elements are cooled by a forced air system consisting of a shrouded aluminum fan blade directly driven by a motor. The motor is energized by a contactor and protected by a circuit breaker. Airflows vertically through the Load Bank, from bottom to top, through screened intake and exhaust vents.

Cooling Failure

If a cooling failure occurs the load will be de-energized. Before reapplying a load, the failure must be corrected and the system must be reset by turning the Load Bank “Off” then “On”.

This is a permissive/energize-to-run circuit in which all safety sensors must energize their control relays on normal operation before load can be applied. This system will include the following components:

1. Thermocouples into Programmable Logic Controller (PLC) for intake and exhaust
2. Pressure Switch (PS)

Thermocouples

The thermocouples setpoints have been factory adjusted for precise Load Bank over temperature protection under normal operating conditions. Unusual operating conditions may require field adjustment. The setpoints may be changed via the touch panel. Consult the Simplex Service Department (217-483-1600 24hrs) before changing the temperature switch setpoint.

LOAD SYSTEM

The load system consists of independently controlled resistive elements located in the Load Bank. Load step control is achieved via the load buttons on the Main Control Screen and the Maintenance Screen.

Load voltage is automatically detected when the operator uses the Main Control Screen but it may be manually selected when using the Maintenance Screen. If the voltage is incorrectly selected while voltage is present on the bus an over voltage will be indicated and the Load Bank will be inoperative.

Load Elements

The Electra Load Bank utilizes specially designed, “Powr-Web” resistive elements. The elements are rigidly supported by high temperature, ceramic clad, stainless steel rods. Element to element short circuits are virtually eliminated. The elements are assembled in discrete trays which are assembled in a vertical “stack”. Each tray is independently serviceable without disturbing adjacent trays.

PRIMARY INSPECTION

Preventative visual inspections of this Load Bank are advised. Physical or electrical problems due to handling and vibration may occur. Never apply power to a Load Bank before performing this procedure. The following 13 Point / 30 Minute Inspection is recommended before initial operation, as part of the 50 hour / 6 month maintenance schedule and whenever a Load Bank is relocated:

1. If crate shows any signs of damage examine the Load Bank in corresponding areas for signs of initial problems.

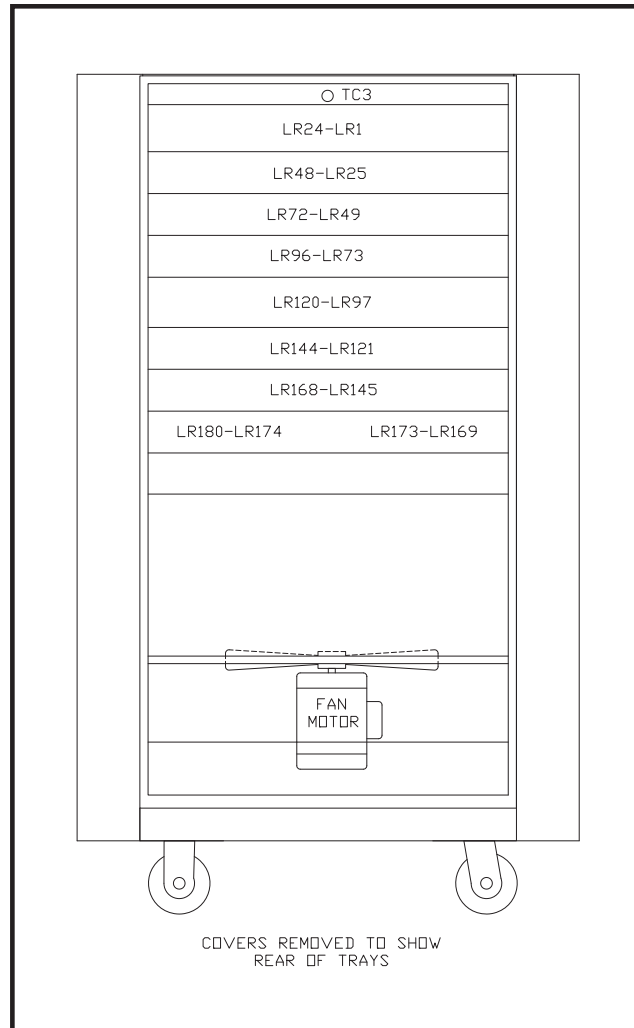

Part of Typical Tray Layout Drawing

2. Check the entire outside of the cabinet for any visual damage which could cause internal electrical or mechanical problems due to reduced clearance.
3. Operate all hinged panels and doors for smooth and safe operation, try all latches and knobs.
4. Rotate and push all switches through all positions to ensure smooth operation.

5. Check cooling system by inspecting fan motor and blade. Check fan blades for stress fractures. Slowly rotate blade by hand and note clearance of blade tip through its rotation near the housing. Observe free rotation of motor shaft.
6. Inspect components by opening all accessible panels. Make sure all components are secure in their bases and safety bails are in place. Spot check electrical connections for tightness. If any loose connections are found inspect and tighten all electrical connections.
7. Check controller(s) for any damage that may occur during shipping.
8. Open cable compartment, inspect load cables, cable bus, cable bus hardware. Check cable door operation.
9. Examine all accessible internal electrical components such as fuses, contactors and transformers. Check lugged wires at these components.
10. Remove rear bolt-on panel. Inspect fuse/contactor and fuse/bus connections.
11. Check wheel operation by moving Load Bank on smooth surface.
12. Inspect bottom of crate/enclosure for any components that may have jarred loose during shipment such as indicator light lenses, switch knobs, etc.
13. Visually inspect element chamber for foreign objects, broken ceramic insulators, mechanical damage.

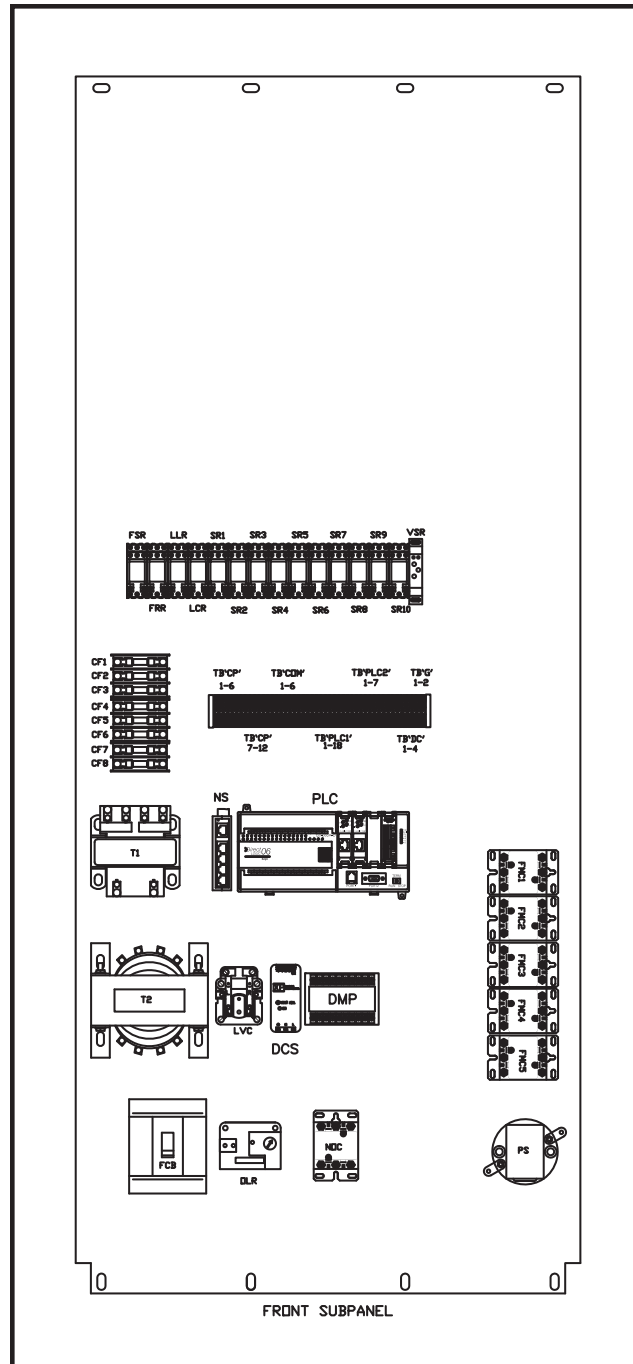

Part of Typical Subpanel Drawing

If any problems are observed during Primary Inspection call the Simplex Service Manager at 217-483-1600 (24hrs.)

LOCATION, SETUP AND CONNECTIONS

Use the casters, eyehooks and forklift channels to position the Load Bank. Location of the Load Bank is of prime importance and should be done by trained personnel. It is one of the most critical factors involved in safe operation. The Load Bank must be positioned and installed according to large airflow requirements, as exhaust temperatures can easily exceed 300° F within 10 feet of the exhaust outlet. Never point the exhaust at a nearby surface or object which may be adversely affected by high temperature. Never operate the Load Bank in a confined space without regard for adequate intake of air and provision for exit of high temperature exhaust.

1. Confirm the test source is properly grounded and ground the Load Bank to its own independent ground.
2. Verify the Fan Circuit Breaker (FCB) is in the "Off" position.
3. *See Control Interconnect Drawing.* Using customer supplied CAT-5, 5E or 6 ethernet cable connect Load Bank(s) to controller(s) as shown for the desired system configuration.
4. *See Controller Wiring Drawing.* Using supplied control power cord connect the controller(s) to the Load Bank convenience receptacle or customer supplied 120V, 1ø, 60Hz source as shown.



WARNING
The Power Receptacle on the Load Bank is not current protected and should only be used for the Fan/Control Power Cord Plug.

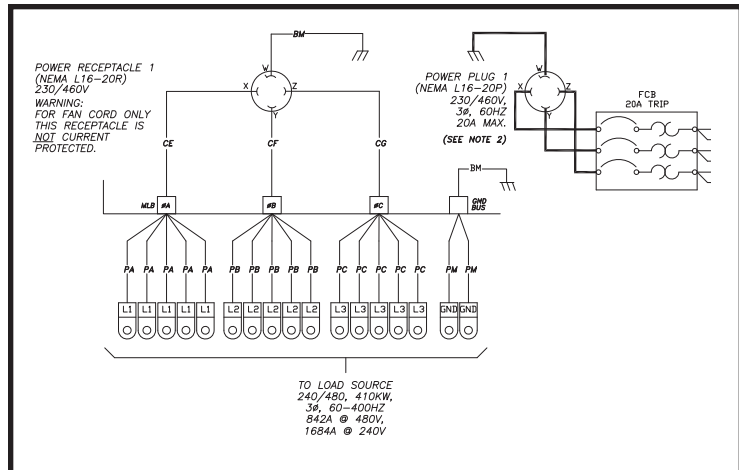

Part of Typical Power Distribution Drawing

5. *See Power Distribution Drawing.* Connect the Fan/Control Power:

Internal Control Power

Plug the Control Power Cord into the receptacle in the rear of the Load Bank.

External Control Power

Plug the Control Power Cord into to a 230/460V, 3ø, 60Hz, 20A receptacle.

6. *See Load Drawing.* Using the cables provide connect the Load Bank to the load source as shown.
7. Place the Fan Circuit Breaker (FCB) is in the "On" position.



WARNING
Connect all load cables to load source or isolate unused cables. Disconnected cables may be energized during load source application.

OPERATION

1. Start-up generator set or bring other test source on line.
2. Press the “Control Power” “On” button on the Main Screen.

If multiple units are connected to form one system the Main Screen is only available via the Master Load Bank.

3. Visually observe correct fan operation, check air intake for obstructions, confirm positive air flow and investigate any unusual fan related noises.
4. Verify normal operation indication in the “System” area of the screen before proceeding.

Total units available and total KW available will be indicated.

System and individual unit status condition will be indicated.

5. Adjust the voltage and frequency of the generator.
6. Press the “KW to Apply” button and enter the desired load.
7. Press the “Apply” button.

Pressing the “Remove” button will remove all load.

8. If desired the operator may access the Metering Line Trends, Single Unit Monitoring or Maintenance Mode screens from the Main Screen.

Data logging is available from the Metering Line Trends Screen by pressing the Data Logging button while a customer supplied USB flash drive is inserted into the USB port.

The Single Unit Monitoring Screen, without a “Previous Screen” button, is the default screen on slave units.

9. Monitor and adjust load steps as needed.

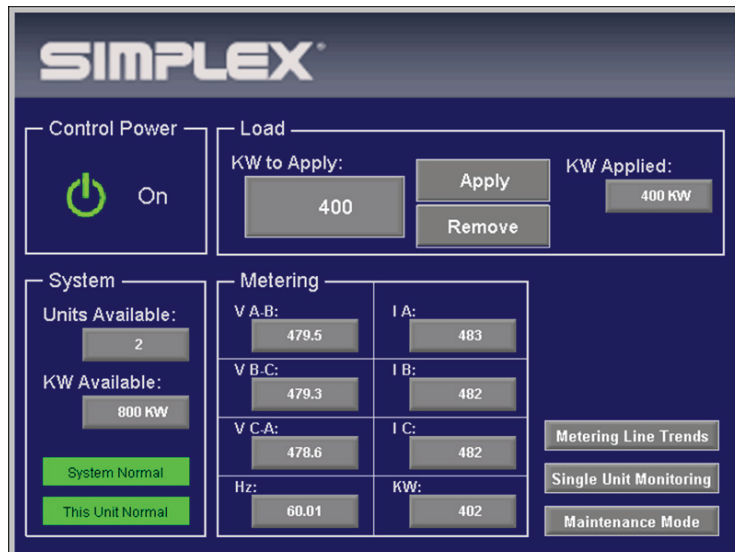

Main Screen

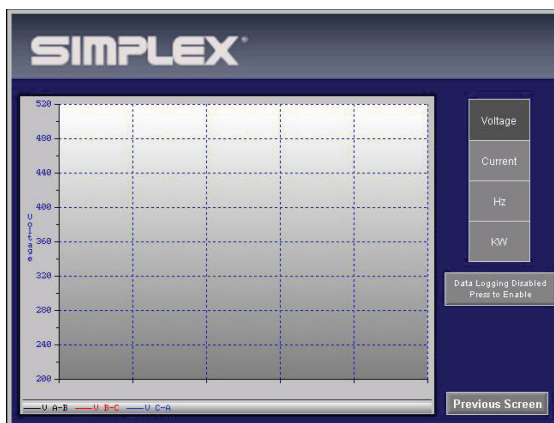

Metering Line Trends Screen

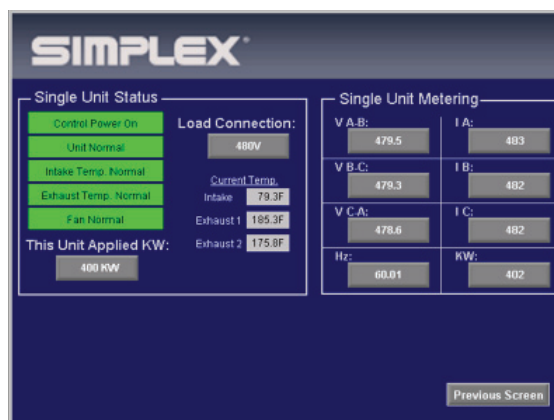

Single Unit Monitoring Screen

SHUTDOWN

1. Remove all load.
2. Allow the cooling fan to run for approximately five minutes to provide a thorough cool down for the entire system.
3. Press the “Fan/Control” button to the “Off” position.
4. Turn off the test source. Disconnect the cables and store them in the cable compartment. Disconnect the controller(s) and ethernet cable(s) and store them appropriately.

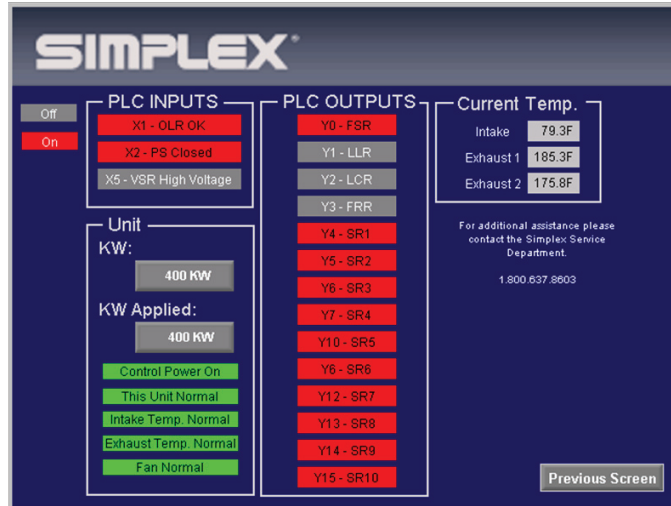

Diagnostics Screen

DIAGNOSTICS SCREEN

The Diagnostic Screen is used to check the status and settings of the Programmable Logic Controller (PLC) along with unit KW, KW applied, status conditions, and temperatures.

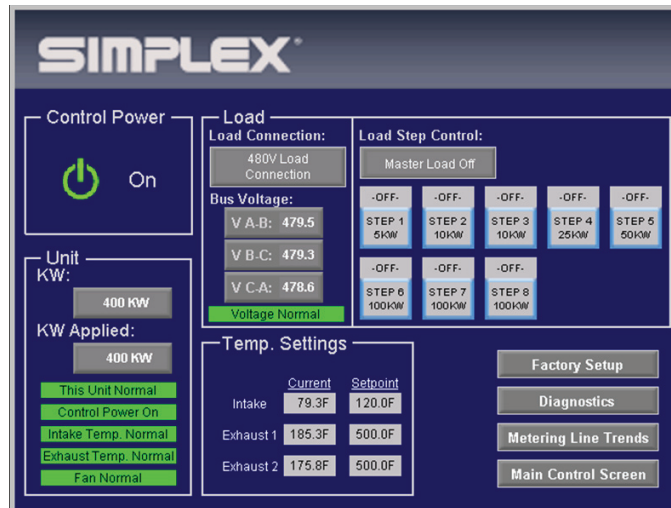

Maintenance Screen

MAINTENANCE SCREEN

The Maintenance Screen is used to check unit KW, KW applied, status conditions, temperatures, individual load steps, and bus voltages. By pressing the “Load Connection” button the operator has the ability to manually select 240V or 480V. If 240V is selected while a high voltage is present on the bus an over voltage will be indicated and the Load Bank will be inoperative. Contact the Simplex Service Department if any factory settings need to be modified.

MAINTENANCE

The Load Bank has been designed to require minimum maintenance. All components have been chosen for a long, reliable life. Two basic intervals of maintenance are required: each operation and every 50 hours or 6 months (whichever comes first).

EACH OPERATION

The air intake screens and louvers, fan and cooling chamber, and exhaust openings must be checked for any obstructions or foreign objects. Check fan blades for stress fractures. Due to the high volume of air circulated, paper and other items can be drawn into the air intakes. During Load Bank operation insure that air is exiting from the exhaust vent.

The load branches should be checked for blown fuses or opened load resistors. To check the fuses or load resistors, operate the Load Bank from a balanced 3-phase source and check the three line currents. The three current readings should be essentially the same. If a sizeable difference is noted one or more load fuses or load resistors may have malfunctioned.

EVERY 50 HOURS OR 6 MONTHS

Check the tightness of the electrical connections. The expansion and contraction caused by Load Bank operation may result in loose connections. The vibrations caused by the cooling fan may also loosen electrical connections. If the Load Bank is transported “over the road”, the electrical connections should be checked for tightness at a shorter-than-normal time interval. See “Primary Inspection”.

MOTOR LUBRICATION

Motors are properly lubricated at the time of manufacture. It is not necessary to lubricate at the time of installation unless the motor has been in storage for a period of 12 months or longer (refer to lubrication procedure that follows).

Inspect the fan motor supplied with your Load Bank for grease fittings. If the motor contains grease fittings you must lubricate the motor. If lubrication instructions are shown on the motor nameplate, they will supersede this general instruction. Belt driven cooling fans have bearings which should be lubricated. Bearings should be lubricated every 50 hours of operation or 6 months whichever comes first.



For continued safety and for maximum equipment protection, always replace fuses with one of equal rating only.



If motor is nameplated for hazardous locations, do not run motor without all of the grease or drain plugs installed.



If lubrication instructions are shown on the motor nameplate, they will supersede this general instruction.

Lubrication Procedure

1. Stop motor. Disconnect and lock out of service.
2. Remove contaminants from grease inlet area.
3. Remove filler and drain plugs.
4. Check filler and drain holes for blockage and clean as necessary.
5. Add property type and amount of grease. See the **Relubrication Time Intervals** table for service schedule and **Relubrication Amounts** table for volume of grease required.

6. Wipe off excess grease and replace filler and drain plugs.

7. Motor is ready for operation.

Warning: If motor is nameplated for hazardous locations, do not run motor without all of the grease or drain plugs installed.

Grease Type

Unless stated otherwise on the motor nameplate, the motors on this Load Bank are pregreased with a polyurea mineral oil NGLI grade 2 type grease. Some compatible brands of polyurea mineral base type grease are:

- Chevron SRI #2
- Rykon Premium #2
- Exxon Polyrex EM
- Texaco Polystar RB

RELUBRICATION TIME INTERVAL for motors with regreasing provisions.						
	NEMA Frame Size					
	140 – 180		210 – 360		400 – 510	
	1800 RPM and less	Over 1800 RPM	1800 RPM and less	Over 1800 RPM	1800 RPM and less	Over 1800 RPM
Standard	3 yrs.	8 mo.	2 yrs.	8 mo.	1 yr.	3 mo.
Severe	1 yr.	3 mo.	1 yr.	3 mo.	6 mo.	1 mo.
Seasonal	See Note 2.					
<p>Standard: Up to 16 hours of operation per day, indoors, 100°F maximum ambient.</p> <p>Severe: Greater than 16 hours of operation per day. Continuous operation under high ambient temperatures (100° to 150°F) and/or any of the following: dirty, moist locations, high vibration (above NEMA standards), heavy shock loading, or where shaft extension end is hot.</p> <p>Seasonal: The motor remains idle for a period of 6 months or more.</p> <p>Note:</p> <ol style="list-style-type: none"> 1. For motors nameplated as “belted duty only” divide the above intervals by 3. 2. Lubricate at the beginning of the season. Then follow service schedule above. 						

RELUBRICATION AMOUNTS for motors with regreasing provisions.	
NEMA Frame Size	Volume cu. in. (fluid oz.)
140	.25 (.14)
180	.50 (.28)
210	.75 (.42)
250	1.00 (.55)
280	1.25 (.69)
320	1.50 (.83)
360	1.75 (.97)
400	2.25 (1.2)
440	2.75 (1.5)
500	3.00 (1.7)

TROUBLESHOOTING

The following section is designed to aid the electrical technician in basic Load Bank system troubleshooting. All of the problems listed can be verified with a basic test meter and/or continuity tester. When troubleshooting a Load Bank system always remove all test source power, fan/control power, anti-condensation heater power, etc.

COOLING FAN MOTOR WILL NOT OPERATE

1. Inoperative Fan Circuit Breaker (FCB)
2. Fan/Control Power not available/incorrect
3. Inoperative Fan Motor (MOT)
4. Fan Motor Contactor (FMC) de-energized
5. Restriction of air (intake or exhaust)
6. Inoperative Voltage Sensing Relay (VSR), Load Voltage Contactor (LVC), and/or Load Contactor Relay (LCR)

COOLING FAILURE INDICATED

Exhaust temp above EXTS setpoint:

1. Over temperature sensor failure
2. Fan failure
3. Air restriction (intake or exhaust)
4. Overvoltage condition present

Exhaust temp below EXTS setpoint:

1. Restriction of air (intake or exhaust)
2. Fan pressure switch inoperative
3. Overtemperature sensor failure

⚠ WARNING ⚠

When troubleshooting Load Bank systems always remove all test source power, fan/control power, anti-condensation heater power, etc.

⚠ WARNING ⚠

If a failure occurs the corresponding status indicator will show a failure and the load will be de-energized. Before reapplying a load, the failure must be corrected and the system must be reset by turning the Load Bank “Off” then “On”.

⚠ WARNING ⚠

Overgreasing is a major cause of bearing and/or motor failure. The amount of grease added should be carefully controlled. Also make sure dirt and contaminants are not introduced when adding grease.

SOME LOAD STEPS CANNOT BE ENERGIZED

1. Open load step resistor(s)
2. Inoperative load step relays
3. Inoperative load step contactors
4. Open load step fuses

LOAD OVER VOLTAGE INDICATED

1. Load Voltage incorrectly selected on the Maintenance Mode Screen

DRAWINGS AND PARTS LIST

The drawings included in this manual are the most accurate source of part numbers for your Load Bank. When ordering replacement parts for Simplex Load Banks, always consult the Parts Legend on the right hand side of the applicable drawing. When contacting the Simplex Service Department always have your work order and drawing number ready for reference. The Load Bank Specifications Sheet in the front of this manual lists all of the drawings included in this manual. The Work Order Number and the Drawing Numbers are also located on each drawing legend. *A typical drawing legend and parts list is illustrated at right.*

SIMPLEX™		SPRINGFIELD, ILLINOIS
SCALE :	APPROVED BY :	DRAWN BY : AMN
DATE : 11/13/10		REVISED :
RESISTIVE LOAD BANK 700KW,240/480V,3 ϕ ,60HZ		ELECTRA-700 POWER DISTRIBUTION
W.O.# 74793-10-41/1-3		DRAWING NUMBER 216331

ITEM	QTY	PART#	DESIG	DESCRIPTION
1	6	DWG215932	LR1-L6	LOAD RESISTORS 833W @ 240V HELICAL COIL
2	12	DWG215932	LR7-LR18	LOAD RESISTORS 1667W @ 240V POWER-WEB
3	6	DWG215932	LR18-LR24	LOAD RESISTORS 4167W @ 240V POWER-WEB
4	156	DWG215932	LR25-LR180	LOAD RESISTORS 4167W @ 120V POWER-WEB
5	14	13011040	C1A-4A, NDC C1B-4B FMC1-5	CONTACTOR, 3-POLE 40A-RESISTIVE, 600VAC 120VAC, 50/60Hz
6	26	13011065	C5A-17A C5B-17B	CONTACTOR, 3-POLE 65A-RESISTIVE, 600VAC 120VAC, 50/60Hz
7	1	13007000	LVC	POWER RELAY, DPDT 40A-300VAC, 5A-600VAC 24VDC COIL, 10VA, 1½ Hp
8	2	14009500	CF1, 2	FUSE, TIME DELAY 1.5A, 600V, 200KAIC
9	4	14014500	CF3, MF1-MF3	FUSE, FAST ACTING 2A, 600V, 200KAIC
10	2	14012000	CF7-8	FUSE, TIME DELAY 2A, 600V, 200KAIC
11	2	14012500	RF	FUSE, TIME DELAY 2A, 250V, 100KAIC
12	2	14026000	CF4, 5	FUSE, TIME DELAY 4A, 600V, 200KAIC
13	1	14044075	CF6	FUSE, FAST ACTING 10A, 600V, 200KAIC
14	12	14074000	F1-12	FUSE, VERY FAST ACTING 35A, 600VAC, 200KAIC
15	78	14087000	F13-90	FUSE, VERY FAST ACTING 70A, 600VAC, 200KAIC
16	1	15012100	[CF7, 8]	FUSEBLOCK 30A, 600V, 2 POLE QUICK-CONNECT

APPENDIX A - ABBREVIATIONS USED IN THIS MANUAL

Listed below are abbreviations of terms found on Simplex Load Bank Systems. When following a load bank drawing utilize this guide to define abbreviated system and component names. As this is a master list, drawings and text pertaining to your equipment may not contain all these terms.

AC-Alternating current

AIC-Ampere interrupting current-maximum short circuit fault current a component can safely interrupt

AM-Ammeter

AMSW- Ammeter selector switch-selects any phase for current reading

CF-Control fuse

CFM-Cubic feet per minute-used to rate fan air flow capacity and load bank cooling requirement

CFR-Cooling failure relay-normally energized relay in cooling failure subsystem

CPC-Control power contactor

CPF-Control power fuse

CT-Current transformer- used in metering circuits

DC-Direct current

EXTS-Exhaust air temperature switch

FCB-Fan circuit breaker-circuit breaker in series with fan control power

FCVR-Fan control voltage relay-normally energized relay on relay sub-panel

FM-Frequency meter-monitors frequency of test source

FMC-Fan motor contactor-controls power to fan motor

FMSW-Frequency meter switch

FPS-Fan power switch-used to energize cooling system

GFB-Ground fault breaker

GBTR-Ground breaker tripped relay

HMI-Operator Interface

HVR-High voltage relay

Hz-Hertz-cycles per second, measurement of frequency

IFCV-Incorrect fan/control voltage

INTS-Intake air temperature switch

K-Relay coil/contact designation

KVA-Kilovolt amperes

KVAR-Kilovolt amperes-reactive

KW-Kilowatts

KWM-Kilowatt meter

KWT-Kilowatt meter transducer

LM-Louver motor

LMC-Louver motor contactor

LR-Load resistive element

LX-Load reactive element

L1-Line 1

L2-Line 2

L3-Line 3

MCB-Main circuit breaker

MDS-Main Disconnect Switch

MF-Meter fuse

MLB-Main Load Bus

MOT-Motor

NEMA-National electrical manufacturer's association

ODP-Open, drip-proof-refers to motor enclosure

OVR-Overvoltage relay-relay used in overvoltage failure system, located on relay sub-panel

OLR-Overload relay-used for motor protection

OTR-Overtemperature relay-used in failure system

PF-Power factor-in resistive only loads expressed as unity (1.0), in inductive loads expressed as lagging, in capacitive loads expressed as leading

PAR-Control power available relay-relay energized when control power is available

PFM-Power factor meter

PS-Pressure switch-switch used to detect fan failure

RR-Reset relay

RTM-Running time meter-keeps time log of equipment use.

TB-Terminal block

TDR-Time delay relay-relay which times out before contacts change state

TEFC-Totally enclosed, fan cooled-refers to motor enclosure

TEAO-Totally enclosed, air-over-refers to motor enclosure

UPS-Uninterruptable power source

V-Voltage

VSR-Voltage sensing relay

XCB-Reactive load controlling circuit breaker

APPENDIX B - CALCULATIONS & FORMULAS

The following calculations are used to determine the actual kilowatt load being applied by the Load Bank, when line voltages and currents are known (at 1.0 power factor).

3 Phase

1. Read all three line currents and find the average reading.
2. Read all three line-to-line voltages and find the average reading.
3. Multiply the average current times the average voltage.
4. Multiply the answer of step #3 times the square root of 3 (1.732).
5. Divide the answer of step #4 by 1000. The answer is the actual kilowatts of load being applied by the Load Bank.

Single Phase

1. Determine the line current.
2. Determine the line-to-line voltage.
3. Multiply the line current times the line-to-line voltage.
4. Divide the answer of step #3 by 1000.
5. The answer of step #4 is the actual kilowatts being applied by the load bank.

EXAMPLES

Using line voltages and currents:

3 Phase

Current Readings	Voltage Readings
A ₁ = 249A	V ₁₋₂ = 481V
A ₂ = 250A	V ₂₋₃ = 479V
A ₃ = 254A	V ₃₋₁ = 483V

$$\begin{aligned} \text{Average Current} &= \frac{A_1 + A_2 + A_3}{3} \\ &= \frac{249 + 250 + 254}{3} \\ &= 251\text{A} \end{aligned}$$

$$\begin{aligned} \text{Average Voltage} &= \frac{V_{1-2} + V_{2-3} + V_{3-1}}{3} \\ &= \frac{481 + 479 + 483}{3} \\ &= 481\text{V} \end{aligned}$$

$$\begin{aligned} \text{Kilowatts} &= \frac{\text{Volts} \times \text{Amps} \times 1.732}{1000} \\ &= \frac{481 \times 251 \times 1.732}{1000} \\ &= 209.1\text{KW} \end{aligned}$$

Single Phase

Current Reading: 150A Voltage Reading: 240V

$$\begin{aligned} \text{Kilowatts} &= \frac{\text{Volts} \times \text{Amps}}{1000} \\ &= \frac{150 \times 240}{1000} \\ &= 36.1\text{KW} \end{aligned}$$

The following calculations are used to determine the amount of current when the desired amount of kilowatts is applied at 1.0 power factor.

3 Phase

1. Multiply the desired amount of kilowatts to be applied by 1000.
2. Multiply the operating voltage times the square root of 3 (1.732)
3. Divide the answer of step #1 by the answer of step #2.
4. The answer of step #3 is the average line current with the desired kilowatts applied at 1.0 power factor.

Single phase

1. Multiply the desired amount of kilowatts to be applied by 1000.
2. Divide the answer of step #1 by the operating voltage.
3. The answer of step #2 is the average line current with the desired amount of kilowatts applied at 1.0 power factor.

The following calculations are used to determine a step kilowatt rating at other than a rated voltage. This is accomplished by referencing the load step to a KW value at a known voltage.

1. Determine the new unrated operating voltage.
2. Divide the new operating voltage by the reference voltage.
3. Square the answer of step #2.
4. Multiply the answer of step #3 times the reference kilowatt value of the load step which the new kilowatt rating is desired.
5. The answer of step #4 is the kilowatt rating of the load step at the new voltage.

EXAMPLES

When desired amount of kilowatts is applied at 1.0 PF:

3 Phase

Applied: 50KW Operating Voltage: 480V

$$\begin{aligned} \text{Amperage} &= \frac{\text{KW} \times 1000}{\text{Volts} \times 1.732} \\ &= \frac{50 \times 1000}{480 \times 1.732} \\ &= \frac{50,000}{831.36} \\ &= 60.1 \end{aligned}$$

Single Phase

Applied: 25KW Operating Voltage: 240V

$$\begin{aligned} \text{Amperage} &= \frac{\text{KW} \times 1000}{\text{Volts}} \\ &= \frac{25 \times 1000}{240} \\ &= \frac{25,000}{240} \\ &= 104.2 \end{aligned}$$

Determining step KW at other than rated voltage:

Applied: 80KW Operating Voltage: 450V
 Rated Voltage: 480V

$$\begin{aligned} \text{Step KW} &= (\text{Oper. Volt.} \div \text{Rated Volt.})^2 \times \text{Applied KW} \\ &= (450 \div 480)^2 \times 80 \\ &= .9375^2 \times 80 \\ &= 70.3 \end{aligned}$$

FORMULAS

		<u>Alternating Current</u>	<u>Direct Current</u>
Kilowatts	1 phase	$\frac{\text{Volts} \times \text{Amps} \times \text{PF}^*}{1000}$	$\frac{\text{Volts} \times \text{Amps}}{1000}$
	3 phase	$\frac{1.732 \times \text{Volts} \times \text{Amps} \times \text{PF}^*}{1000}$	
*Power Factor, expressed as decimal. (Resistive Load Bank PF is 1.0)			
Amperes (KW known)	1 phase	$\frac{\text{KW} \times 1000}{\text{Volts} \times \text{PF}}$	$\frac{\text{KW} \times 1000}{\text{Volts}}$
	3 phase	$\frac{\text{KW} \times 1000}{1.732 \times \text{Volts} \times \text{PF}}$	
KVA	1 phase	$\frac{\text{Volts} \times \text{Amps}}{1000}$	
	3 phase	$\frac{1.732 \times \text{Volts} \times \text{Amps}}{1000}$	
Amperes (KVA known)	1 phase	$\frac{\text{KVA} \times 1000}{\text{Volts}}$	
	3 phase	$\frac{\text{KVA} \times 1000}{1.732 \times \text{Volts}}$	
KVAR	1 phase	$\frac{\text{Volts} \times \text{Amps} \times \sqrt{1-\text{PF}^2}}{1000}$	
	3 phase	$\frac{1.732 \times \text{Volts} \times \text{Amps} \times \sqrt{1-\text{PF}^2}}{1000}$	

APPENDIX C - TORQUE VALUES

FAN BLADES		
FAN PART NO.	BOLT SIZE	TORQUE FT LBS // IN LBS
13820000	SET SCREW	11.7 // 140
13820500	SET SCREW	11.7 // 140
13821000	SET SCREW	8.3 // 100
13822000	1/4 — 20	7.5 // 90
13823000	1/4 — 20	7.5 // 90
13824000	1/4 — 20	7.5 // 90
13825100	1/4 — 20	7.5 // 90
13826000	1/4 — 20	7.5 // 90
13827500	5/16"	13 // 156
13827600	5/16"	13 // 156
13828000	3/8"	24 // 288

MOTORS, BRACKETS, BUS BAR CONNECTIONS		
BOLT/NUT SIZE	GRADE	TORQUE FT LBS // IN LBS
.250 (1/4-20)	Grade 5, dry	8 // 96
.250 (1/4-20)	Grade 2, dry	5.5 // 66
.312 (5/16)	Grade 5, dry	17 // 204
.312 (5/16)	Grade 2, dry	11 // 132
.375 (3/8)	Grade 5, dry	30 // 360
.375 (3/8)	Grade 2, dry	20 // 240
.437 (7/16)	Grade 5, dry	50 // 600
.437 (7/16)	Grade 2, dry	30 // 360
.500 (1/2)	Grade 5, dry	75 // 900
.500 (1/2)	Grade 2, dry	50 // 600
.562 (9/16) & up	Grade 5, dry	110 // 1320
.562 (9/16) & up	Grade 2, dry	70 // 840

CONTACTORS
See torque values on the front of the contactor.

ELEMENTS/TRAYS		
TERM/NUT SIZE		TORQUE INCH LBS
#6	Rod ends	4
#10	Element Conn.	20
1/4-20	High Voltage	Contact Simplex

MAIN LOAD BLOCKS- ALL SIZES		
CONNECTION	WIRE SIZE	TORQUE FT LBS // IN LBS
LOAD SIDE	4-14AWG	2.9 // 35
LINE SIDE	500MCM-4/0	31 // 375
	3/0-4/0	20 // 240
	2/0-6AWG	10 // 120
	8AWG	3.3 // 40

CIRCUIT BREAKERS		
STYLE	WIRE SIZE	TORQUE INCH LBS
Cutler-Hammer 1-Phase	14-10 AWG	20
	8 AWG	25
	6-4 AWG	27
	3-1/0 AWG	45
Merlin Gerin 3-Phase	14-1/0	50

APPENDIX C - TORQUE VALUES CONT'D

FUSEBLOCKS		
MANUF. PART NO.	WIRE SIZE	TORQUE INCH LBS
BM6031SQ, BM6032SQ, BM6033SQ; 600V, 30A	10-18 AWG	20
T60060-2SR 600V, 60A	10-18 AWG	20
T60030-3CR, 600V, 30A T60060-3CR, 600V, 60A 60100-3CR, 600V, 100A	10-14 AWG	35
	8 AWG	40
	4-6 AWG	45
	2-3 AWG	50

TAPER-LOCK BUSHINGS	
BUSHING NUMBER	TORQUE
1008, 1108	55 IN LBS
1210, 1215, 1310, 1610, 1615	15 FT LBS
2012	23 FT LBS
2517, 2525	36 FT LBS
3020, 3030	67 FT LBS
3535	83 FT LBS
4040	142 FT LBS
4545	204 FT LBS
5050	258 FT LBS
6050, 7060, 8065	652 FT LBS
10085, 12010	1142 FT LBS

MISCELLANEOUS-TERMINALS, METERS, SWITCHES, COILS, RELAYS, XFORMERS	
CONNECTION SIZE	TORQUE INCH LBS
4	5
6	10
8	19
10	31
1/4-20"	66

CAM-LOK STUDS	
THREADED STUD	MAXIMUM TORQUE
5/16" – 18	15 FT LBS
1/2" – 13	40 FT LBS

APPENDIX D - TYPICAL LIFT EYE INSTALLATION

TYPICAL LIFT EYE INSTALLATION

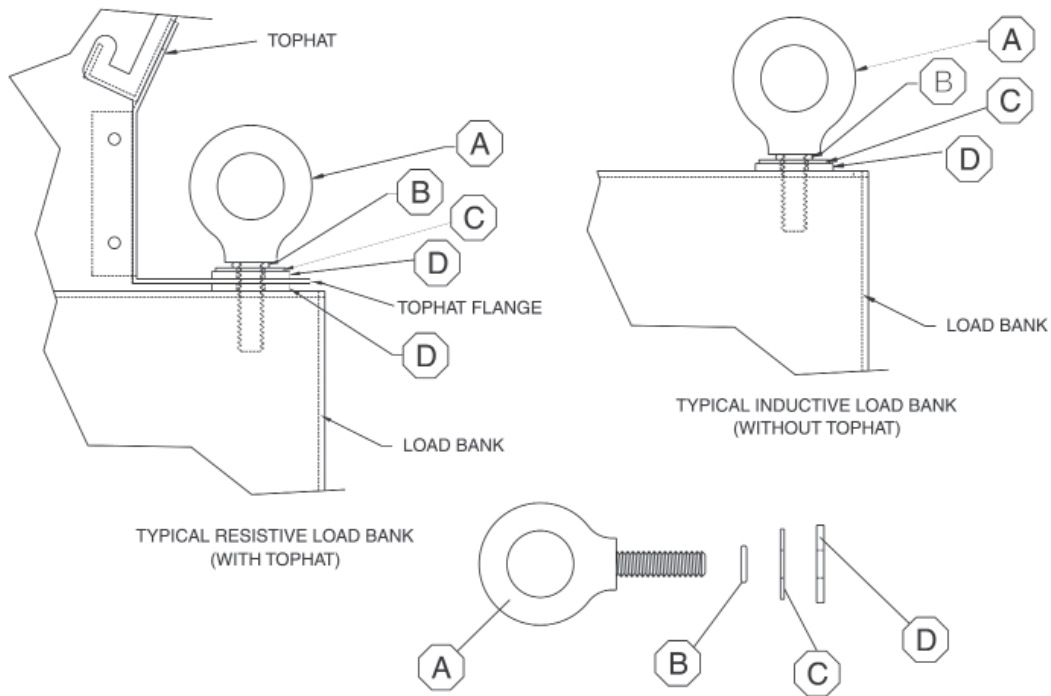

ITEM	DESCRIPTION	1/2"	5/8"	3/4"	7/8"
A	LIFT EYE	15465000	15470000	15471000	15472000
B	O-RING	16750500	16750600	16750610	16750620
C	FLAT WASHER	20424200	20427000	20427100	20427200
D	RUBBER WASHER	20431000	20431001	20431002	20431003