

STATIONARY LOAD BANK TECHNICAL MANUAL

Customer: XXXXXX

Work Order: XXXXX-XX-XX

Model: XXXXX

June 2011

The information herein is the property of Simplex, Inc. and/or its subsidiaries.
Without written permission, any copying, transmitting to others, and other use
except that for which it is loaned, is prohibited.
(File: LBS-TS-110601.indd)

Contents

DESCRIPTION	2
Control System	3
Cooling System.....	4
Load System.....	4
PRIMARY INSPECTION	5
INSTALLATION.....	5
Location	5
Procedure	6
OPERATION.....	7
Manual Operation.....	7
Numeric Load Application	8
Load Dump	8
Diagnostic Screen.....	9
FAILURE DETECTION.....	9
Thermocouples	9
MAINTENANCE	10
Each Operation	10
Every 50 Hours or 6 Months	10
Motor Lubrication	11
TROUBLESHOOTING	12
Cooling Fan Motor Will Not Operate	12
Cooling Failure Indicated	12
Metering System Does Not Operate Properly	13
Some Load Steps Cannot Be Energized.....	13
DRAWINGS AND PARTS LIST	13
APPENDIX A - ABBREVIATIONS USED IN THIS MANUAL.....	14
APPENDIX B - CALCULATIONS & FORMULAS	15
APPENDIX C - TORQUE VALUES.....	18
APPENDIX D - TYPICAL LIFT EYE INSTALLATION	20
APPENDIX E - SATURN BEARINGS	21

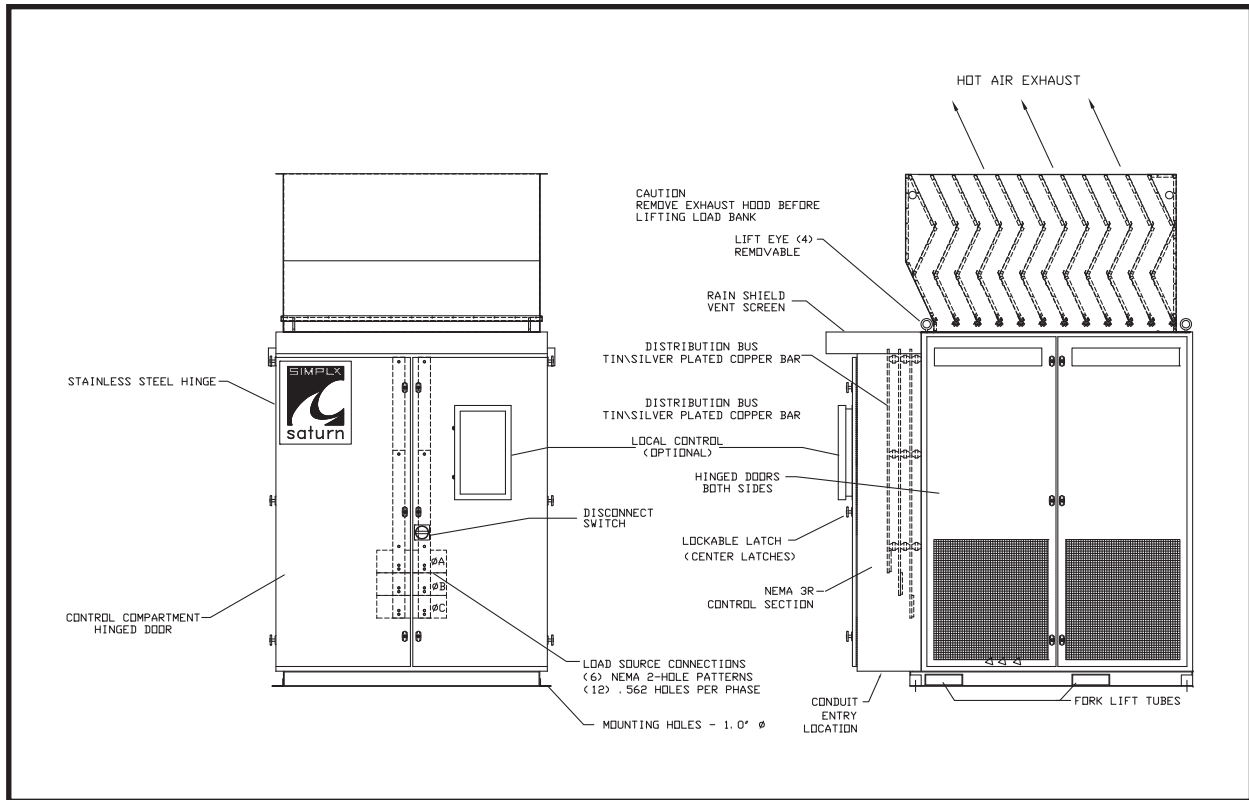

Part of Typical Pictorial Drawing with optional Exhaust Hood

DESCRIPTION

Simplex Stationary Load Banks are precision test instruments specifically designed to apply discrete, selectable electrical load to a power source while measuring the response of the generator to the applied load. They also provide a means for routine maintenance exercise to assure long term reliability and readiness of the standby generator. Exercise Load Banks eliminate the detrimental effects of unloaded operation of diesel engine generators.

Simplex Stationary Load Banks are available in various cabinet designs and capacities. Standard cabinets are rated as Type 3R outdoor weatherproof but are also available as Type 1 indoor. If desired, the Load Bank can be mounted on a trailer.

Power source testing is accomplished by applying resistive load steps at unity (1.0) power factor. See the Load Bank Specifications Sheet in the front of this manual for the rating of your Load Bank.

The illustrations in this manual are examples only and may differ from your Load Bank.

Load application is by magnetic contactor. All load branch circuits are protected by 200,000AIC class-T fuses.



WARNING



Never operate or service a Load Bank that is not properly connected to an earthground.

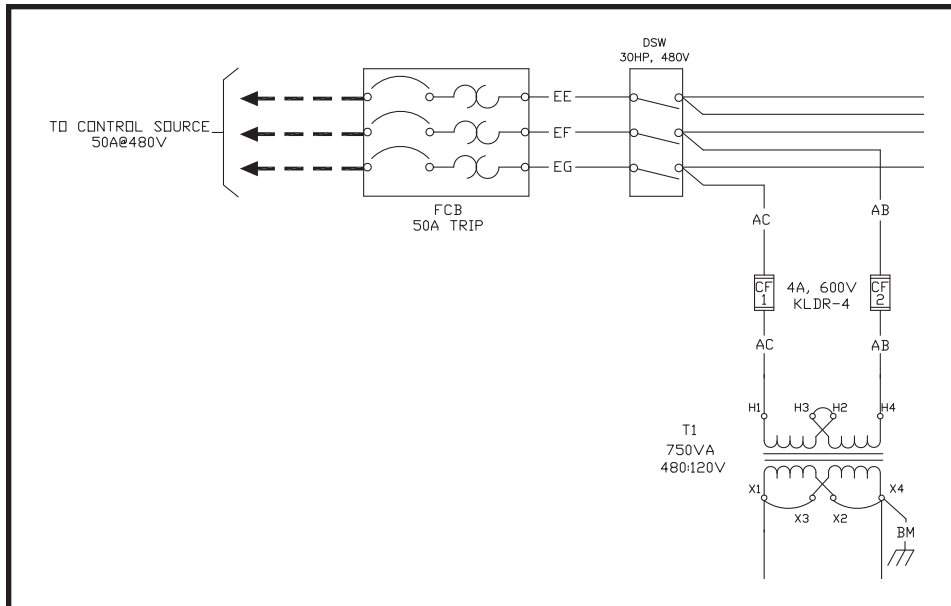

Part of Typical Control Section Drawing

The Load Bank consists of three principal systems:

1. Control System
2. Cooling System
3. Load System

CONTROL SYSTEM

Load Bank operation and status indication is via a Operator Interface (HMI) touchscreen mounted locally on the Load Bank and/or housed in a remote box. The Control System includes a Programmable Logic Controller (PLC) and 120V discrete components. A 24VDC power supply (DCS) located in the Load Bank powers the touchscreen. Common serviceable components include Control Fuses (CF Series) and Power Fuses (F Series). The standard touchscreen is composed of the following screens: Main, Manual Load, Numeric Load, Setup, Metering, and Diagnostic.

The Control System allows the operator to apply a desired load to the test source and measure the response of the test source to the load. This Load Bank is protected against cooling failures (loss of cooling air flow, high intake or exhaust air temperature which could damage the Load Bank or present a safety hazard to the operator). When a cooling failure occurs the automatic safety features immediately remove the load from the load source. The malfunction must be corrected and the Control System must be reset by turning the Load Bank "Off" then "On" before the load can be re-applied.

Control Power (120V) is supplied via the load source and the Control Power Transformer (T1). Control Power is applied to the coil of the Fan Motor Contactor (FMC) through closed Fan Start Relay (FSR) contacts 7-4. Fan power is applied to the Fan Motor (MOT) through the Fan Circuit Breaker (FCB), the Main Disconnect Switch (DSW), the Fan Motor Contactor (FMC) contacts, and an Overload Relay (OLR).

COOLING SYSTEM

Resistive Load Elements are cooled by a forced air system consisting of an aluminum fan blade directly driven or belt driven by a TEFC motor. The fan motor is energized by a 600V, 3 pole contactor and protected by a three pole, 100A frame circuit breaker.

Reactive Load Elements (inductive or capacitive) are convection cooled or cooled by a forced air system.

LOAD SYSTEM

The Load System consists of independently controlled resistive and/or reactive load elements specifically designed for Load Bank systems. They are protected by 200,000AIC, 600VAC fuses.

Simplex Resistive Load Elements conservatively operate at approximately half the maximum temperature rating of the alloy (1080°F vs. 1920°F). For example:

Alloy: FeCrAl

Ratings: 3333W@120V
4170W@139V

Connections: 120V wye (208V),
139V wye (240V, 3 ϕ),
277V wye (480V, 3 ϕ),
240 delta (240V, 3 ϕ), or
480 delta (480V, 3 ϕ).

See Parts Legend Drawing for specific elements used.

These elements are rigidly supported by high-temperature, ceramic-clad, stainless-steel supports. Element-to-element short circuits are virtually eliminated. The elements are assembled in discrete trays which are assembled in a vertical "stack". Each tray is independently serviceable without disturbing adjacent trays.

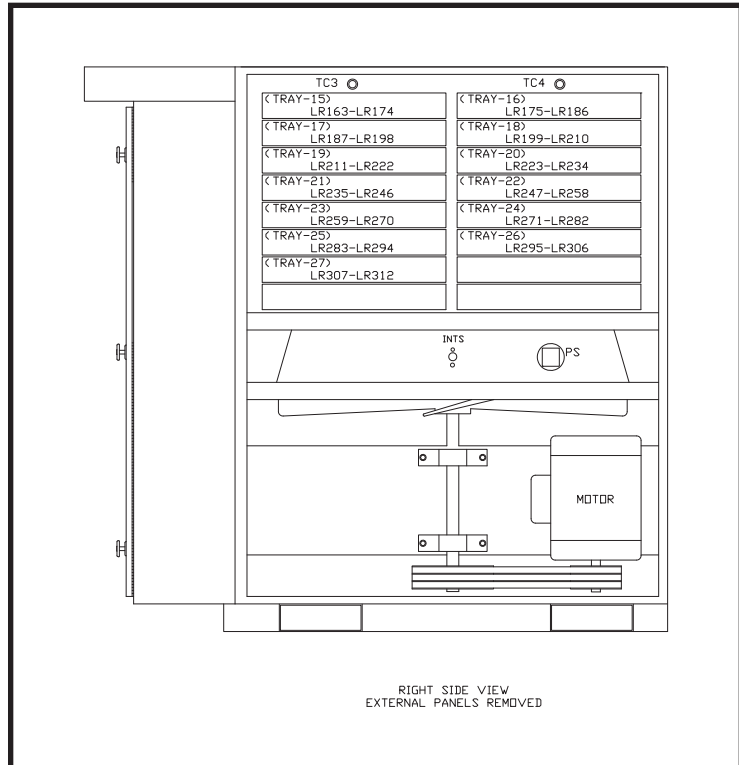

Part of Typical Tray Layout Drawing

Reactive Load Elements are iron-core, non-saturable, air gap calibrated and air cooled. Standard elements are varnish coated. Epoxy coatings are available for severe environments.

WARNING

Always remove all power from the load bus and all fan/control power before servicing the Load Bank. Never operate or service a Load Bank that is not properly connected to an earthground.

WARNING

Do not store or operate in rain or spray unless unit is designed for this service or adequate protection is provided.

PRIMARY INSPECTION

Preventative visual inspections of the shipping crate and Load Bank is advised. Physical or electrical problems due to handling and vibration may occur. Never apply power to a Load Bank before performing this procedure. The following Nine Point/30 Minute Inspection is recommended before installation, as part of the 50 hour / 6 month maintenance schedule and whenever the Load Bank is relocated:

1. If crate shows any signs of damage examine the Load Bank in the corresponding areas for signs of initial problems.
2. Check the entire outside of the cabinet for any visual damage which could cause internal electrical or mechanical problems due to reduced clearance.
3. Inspect all hinged panels and doors for smooth and safe operation, try all latches and knobs.
4. Rotate and push all switches through all positions to ensure smooth operation.
5. Check cooling system by inspecting fan motor and blade. Check fan blades for stress fractures. Slowly rotate blade by hand and note clearance of blade tip through its rotation near the housing. Observe free rotation of motor shaft.
6. Inspect all relays, timers, and control modules by opening all accessible panels. Make sure all components are secure in their bases and safety bails are in place. Spot check electrical connections for tightness. If any loose connections are found inspect and tighten all remaining connections.
7. Examine all accessible internal electrical components such as fuses, contactors and transformers. Check lugged wires at these components.

If any problems are observed during Primary Inspection call the Simplex Service Manager at 217-483-1600 (24hrs.)

8. Inspect bottom of crate/enclosure for any components that may have jarred loose during shipment such as indicator light lenses, switch knobs, etc.
9. Visually inspect element chamber for foreign objects, broken ceramic insulators, mechanical damage.

INSTALLATION

LOCATION

Type 3R Load Banks are intended for outdoor installation. Type 1 Load Banks must be installed indoors. The load elements in this Load Bank are cooled by a forced air system which discharges through the top, sides or the back of the cabinet. This Load Bank will produce a large quantity of exhaust air. Location of the Load Bank is of prime importance and should be done by trained personnel. It is one of the most critical factors involved in safe operation. The Load Bank must be positioned and installed according to large airflow requirements.

- Horizontal airflow Load Banks require a minimum clearance of 25 feet on the discharge side, and 6 feet on all other sides.
- Vertical airflow Load Banks require a minimum clearance of 6 feet on all sides.
- Load Banks installed indoors must be equipped with an exhaust air duct of minimum back pressure (supplied by others) which routes all Load Bank hot exhaust air outdoors.

- Never install any structure or object at any height above the Load Bank.
- Always locate the Load Bank in a secure area accessible by trained personnel only.
- Use the eyehooks and forklift channels provided to position the Load Bank.
- Never move the Load Bank with the exhaust hood attached (if equipped).
- Never point the exhaust at a nearby surface or object which may be adversely affected by high temperature.
- Never operate the Load Bank in a confined space without regard for adequate intake of air and provision for exit of high temperature exhaust.
- Consider that the Load Bank and a nearby generator set may have to compete for cooling air.
- Never bounce hot exhaust air off nearby objects and allow it to recirculate through the cooling system.
- Never operate the Load Bank in proximity to a sprinkler system.

Failure to properly install this Load Bank may result in substantial damage to or the destruction of the Load Bank, adjacent equipment and the building in which the Load Bank is installed.

⚠ WARNING ⚠

Damage to the Load Bank due to improper installation is not covered by the Simplex Warranty.

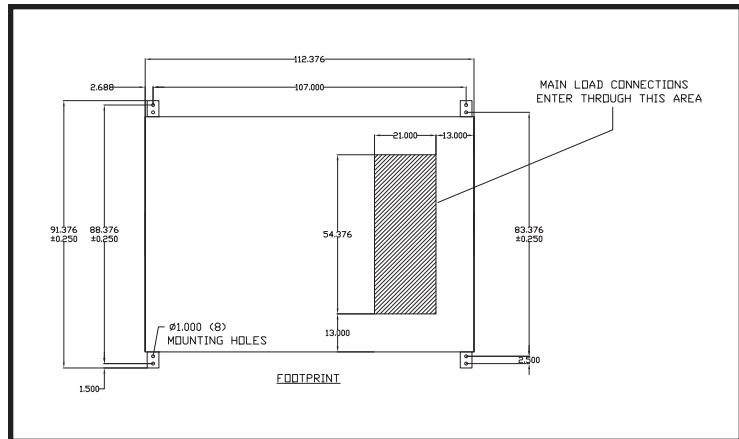

Footprint - Part of Typical Pictorial Drawing

PROCEDURE

Unless specified on the drawing, make all connections in compliance with NEC.

1. Confirm the test source is properly grounded and ground the Load Bank.
2. Confirm the Main Disconnect Switch (DSW) is in the "Off" position.
3. Using the slots and holes provided mount the remote box (if applicable).
4. Per PLC Control drawing connect TB'COM' contacts on the Load Bank to TB'R' contacts on the remote box as shown (if applicable).
5. Per load connection drawings cable the load source to the Load Bank.
6. If the Load Dump feature is desired, remove the factory installed jumper at TB'LD' 1-2 and connect customer supplied Load Dump contacts to TB'LD' 1-2 as shown.
Open contacts to dump load.
Close contacts to enable load.
7. Place the Main Disconnect Switch (DSW) in the "On" position.

OPERATION

The touchscreen is composed of the following screens: Main, Manual Load, Numeric Load, Setup, Metering, and Diagnostic. Pressing the “Status” button when available opens the Main Screen.

MANUAL OPERATION

1. Start-up generator or bring other test source on line.
2. Adjust power source voltage and frequency.
3. Press the “Control Power On” button to energize the cooling fan.

“Control Power is On” will be indicated and Load Bank status indicators will appear.

4. Verify normal operation before proceeding.
5. Visually observe correct fan operation and investigate any unusual fan related noises.
6. Check air intake for obstructions and confirm positive air flow.
7. Press the “Manual Load” button.
8. Select the desired load steps by pressing the appropriate button.

If needed press the “Steps 11-21” button to access the additional steps.

9. Press the “Master Load” button.
This simultaneously applies all of the load steps which are in the “On” position.
Trim is achieved by turning the load steps “On” and “Off” while the “Master Load” is in the “On” position.
10. Adjust source voltage and load. Monitor as needed.

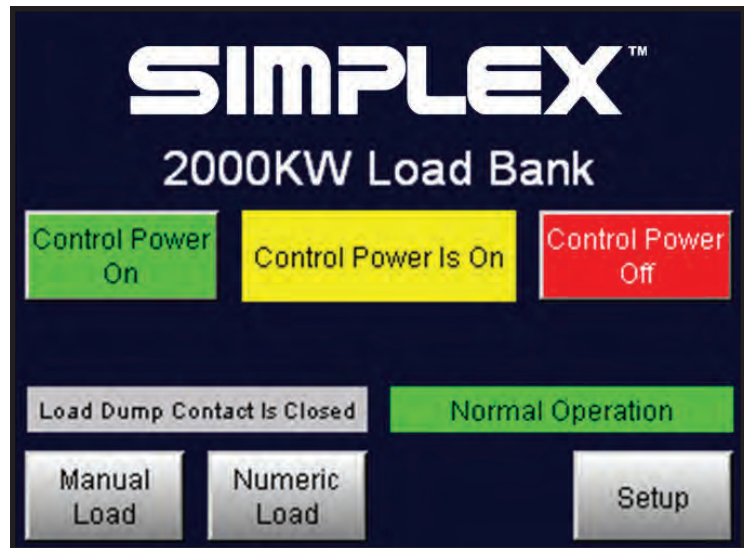

Main Screen

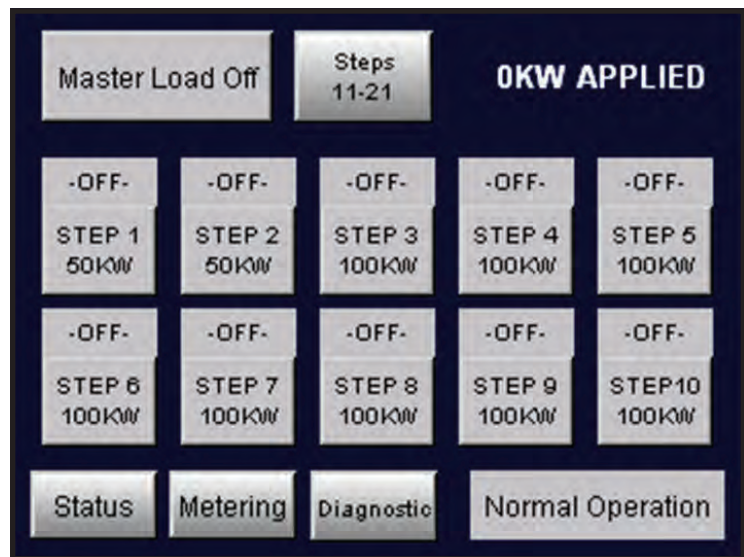

Manual Load Application Screen

Shutdown

1. De-energize the load.
2. Run the cooling fan for 5 minutes to assure a thorough cool down of all load elements (optional).
3. Press the “Control Power Off” button on the Main screen.

NUMERIC LOAD APPLICATION

1. Start-up generator or bring other test source on line.
2. Adjust power source voltage and frequency.
3. Press the “Control Power On” button to energize the cooling fan.
“Control Power is On” will be indicated and Load Bank status indicators will appear.
4. Verify normal operation before proceeding.
5. Visually observe correct fan operation and investigate any unusual fan related noises.
6. Check air intake for obstructions and confirm positive air flow.
7. Press the “Numeric Load” button.
8. Press the “Enter KW Value to Apply” button and enter the desired value in the numeric pop-up screen.
9. Press the “Apply Numeric Load” button.
10. Adjust source voltage and load via the apply and remove buttons. Monitor as needed.

Shutdown

1. De-energize the load.
2. Run the cooling fan for 5 minutes to assure a thorough cool down of all load elements (optional).
3. Press the “Control Power Off” button on the Main screen.

LOAD DUMP

This Load Bank contains a Load Dump feature which de-energizes all applied load when customer supplied contacts open. Normally closed to run, they are rated at 2A @ 24VDC and should be wired to TB‘LD’ 1–2. When these contacts open all applied load will be de-energized and the load section will

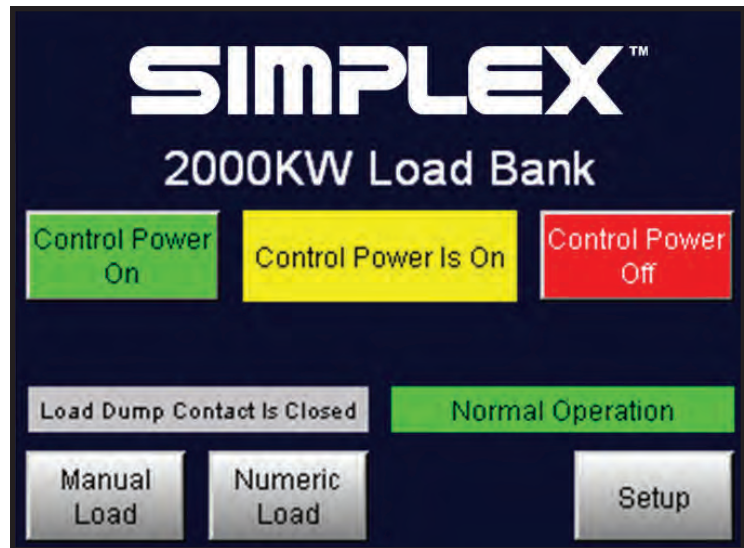

Main Screen

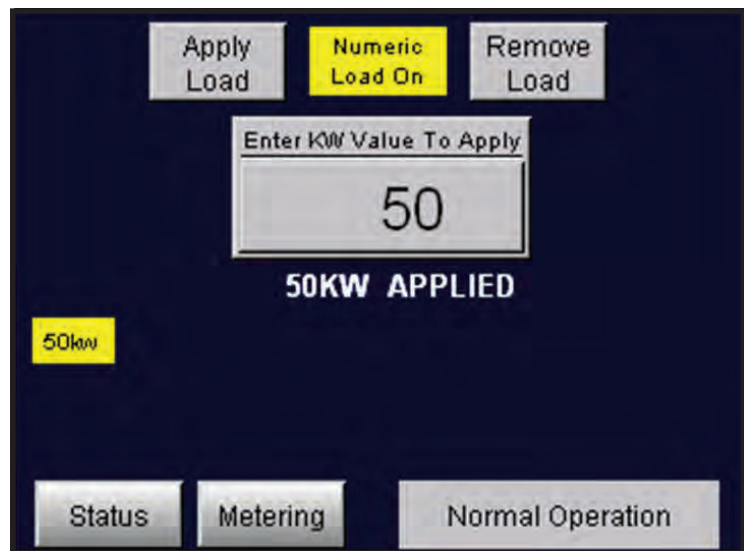

Numeric Load Application Screen

be disabled. If desired, the customer may install automatic transfer switch contacts, a manual pushbutton or circuit breaker for this use. If this feature is used the factory installed jumper at TB‘LD’ 1–2 must be removed (See Installation Procedure).

The operator also has the option of bypassing these contacts and enabling the load section by pressing the “Load Dump Active Press To Bypass” button on the Setup screen.

DIAGNOSTIC SCREEN

The Diagnostic Screen is accessed via the “Diagnostic” button on the Manual Load Screens and Setup Screen. The intake and exhaust setpoints are factory set but may be modified via the Setup Screen (see *Failure Detection* section below).

FAILURE DETECTION

If a failure occurs the corresponding status indicator will be present and the load will be de-energized. Before reapplying a load, the failure must be corrected and the system must be reset by turning the Load Bank “Off” then “On”.

This is a permissive/energize-to-run circuit in which all safety sensors must energize their control relays on normal operation before load can be applied. This system will include the following components:

1. Thermocouples into Programmable Logic Controller (PLC) for intake and exhaust
2. Pressure Switch (PS)

Thermocouples

The thermocouples setpoints have been factory adjusted for precise Load Bank over temperature protection under normal operating conditions. Unusual operating conditions may require field adjustment. The setpoints may be changed via the touch panel. Consult the Simplex Service Department (217-483-1600 24hrs) before changing the temperature switch setpoint.

⚠ WARNING ⚠

Do Not allow the Load Bank to operate unattended for extended periods.

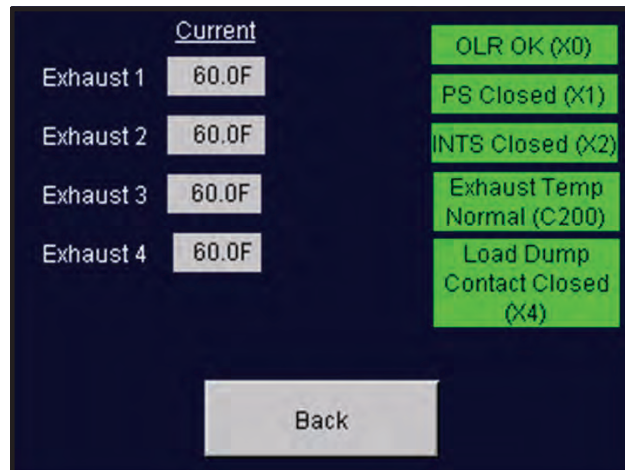

Diagnostic Screen

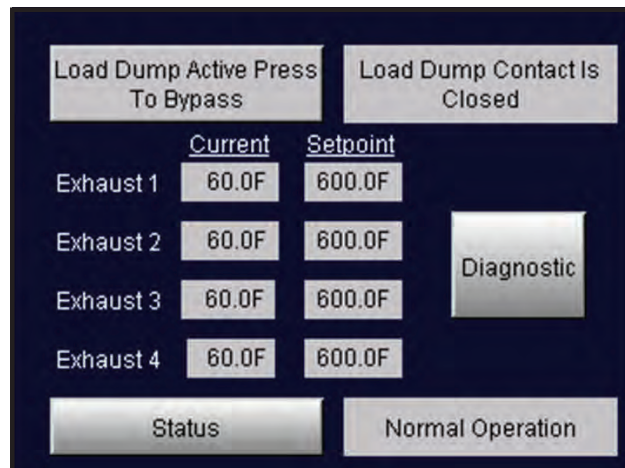

Setup Screen



Metering Screen

MAINTENANCE

The Load Bank has been designed to require minimum maintenance. All components have been chosen for a long, reliable life. Two basic intervals of maintenance are required: each operation and every 50 hours or 6 months (whichever comes first).

EACH OPERATION

The air intake screens and louvers, fan and cooling chamber, and exhaust openings must be checked for any obstructions or foreign objects. Check fan blades for stress fractures. Due to the high volume of air circulated, paper and other items can be drawn into the air intakes. During Load Bank operation insure that air is exiting from the exhaust vent.

The load branches should be checked for blown fuses or opened load resistors. To check the fuses or load resistors, operate the Load Bank from a balanced 3-phase source and check the three line currents. The three current readings should be essentially the same. If a sizeable difference is noted one or more load fuses or load resistors may have malfunctioned.

⚠ WARNING ⚠

If lubrication instructions are shown on the motor nameplate, they will supersede this general instruction.

⚠ WARNING ⚠

The bearings which are used on Saturn Load Banks require special installation and relubrication. See Appendix E - Saturn Bearings for additional information.

EVERY 50 HOURS OR 6 MONTHS

Check the tightness of the electrical connections. The expansion and contraction caused by Load Bank operation may result in loose connections. The vibrations caused by the cooling fan may also loosen electrical connections. If the Load Bank is transported "over the road", the electrical connections should be checked for tightness at a shorter-than-normal time interval. See "Primary Inspection".

⚠ WARNING ⚠

Overgreasing is a major cause of bearing and/or motor failure. The amount of grease added should be carefully controlled. Also make sure dirt and contaminants are not introduced when adding grease.

⚠ WARNING ⚠

If motor is nameplated for hazardous locations, do not run motor without all of the grease or drain plugs installed.

⚠ WARNING ⚠

For continued safety and for maximum equipment protection, always replace fuses with one of equal rating only.

MOTOR LUBRICATION

Motors are properly lubricated at the time of manufacture. It is not necessary to lubricate at the time of installation unless the motor has been in storage for a period of 12 months or longer (refer to lubrication procedure that follows).

Inspect the fan motor supplied with your Load Bank for grease fittings. If the motor contains grease fittings you must lubricate the motor. If lubrication instructions are shown on the motor nameplate, they will supersede this general

instruction. Belt driven cooling fans have bearings which should be lubricated. Bearings should be lubricated every 50 hours of operation or 6 months whichever comes first.

Lubrication Procedure

1. Stop motor. Disconnect and lock out of service.
2. Remove contaminants from grease inlet area.
3. Remove filler and drain plugs.
4. Check filler and drain holes for blockage and clean as necessary.
5. Add proper type and amount of grease. See the **Relubrication Time Intervals** table for service schedule and **Relubrication Amounts** table for volume of grease required.
6. Wipe off excess grease and replace filler and drain plugs.

RELUBRICATION TIME INTERVAL for motors with regreasing provisions.						
	NEMA Frame Size					
	140 – 180		210 – 360		400 – 510	
	1800 RPM and less	Over 1800 RPM	1800 RPM and less	Over 1800 RPM	1800 RPM and less	Over 1800 RPM
Standard	3 yrs.	8 mo.	2 yrs.	8 mo.	1 yr.	3 mo.
Severe	1 yr.	3 mo.	1 yr.	3 mo.	6 mo.	1 mo.
Seasonal	See Note 2.					
<p>Standard: Up to 16 hours of operation per day, indoors, 100°F maximum ambient.</p> <p>Severe: Greater than 16 hours of operation per day. Continuous operation under high ambient temperatures (100° to 150°F) and/or any of the following: dirty, moist locations, high vibration (above NEMA standards), heavy shock loading, or where shaft extension end is hot.</p> <p>Seasonal: The motor remains idle for a period of 6 months or more.</p> <p>Note:</p> <ol style="list-style-type: none"> 1. For motors nameplated as “belted duty only” divide the above intervals by 3. 2. Lubricate at the beginning of the season. Then follow service schedule above. 						

RELUBRICATION AMOUNTS for motors with regreasing provisions.	
NEMA Frame Size	Volume cu. in. (fluid oz.)
140	.25 (.14)
180	.50 (.28)
210	.75 (.42)
250	1.00 (.55)
280	1.25 (.69)
320	1.50 (.83)
360	1.75 (.97)
400	2.25 (1.2)
440	2.75 (1.5)
500	3.00 (1.7)

7. Motor is ready for operation.

Warning: If motor is nameplated for hazardous locations, do not run motor without all of the grease or drain plugs installed.

Grease Type

Unless stated otherwise on the motor nameplate, the motors on this Load Bank are pregreased with a polyurea mineral oil NGLI grade 2 type grease. Some compatible brands of polyurea mineral base type grease are:

- Chevron SRI #2
- Rykon Premium #2
- Exxon Polyrex EM
- Texaco Polystar RB

TROUBLESHOOTING

This section is designed to aid the electrical technician in basic Load Bank system troubleshooting. All of the problems listed can be verified with a basic test meter and/or continuity tester. For safety reasons, when troubleshooting Load Bank systems always remove all test source power, fan/control power, anti-condensation heater power, etc.

COOLING FAN MOTOR WILL NOT OPERATE

1. Inoperative Fan Circuit Breaker (FCB)
2. Fan/Control Power not available/incorrect
3. Inoperative Fan Motor (MOT)
4. Fan Motor Contactor (FMC) de-energized
5. Restriction of air (intake or exhaust)

WARNING

When troubleshooting Load Bank systems always remove all test source power, fan/control power, anti-condensation heater power, etc.

WARNING

If a failure occurs the corresponding status indicator will be present and the load will be de-energized. Before reapplying a load, the failure must be corrected and the system must be reset by turning the Load Bank “Off” then “On”.

COOLING FAILURE INDICATED

Exhaust temp above EXTS setpoint:

1. Over temperature sensor failure
2. Fan failure
3. Air restriction (intake or exhaust)
4. Overvoltage condition present

Exhaust temp below EXTS setpoint:

1. Restriction of air (intake or exhaust)
2. Fan pressure switch inoperative
3. Overtemperature sensor failure

METERING SYSTEM DOES NOT OPERATE PROPERLY

1. Meter voltage switch failure
2. Improper positioning of meter voltage selector switch
3. Current transformer or current transformer wiring failure
4. Test meter failure
5. Meter fuses open

SOME LOAD STEPS CANNOT BE ENERGIZED

1. Open load step resistor(s)
2. Inoperative load step relays
3. Inoperative load step contactors
4. Open load step fuses

DRAWINGS AND PARTS LIST

The drawings included in this manual are the most accurate source of part numbers for your Load Bank. When ordering replacement parts for Simplex Load Banks, always consult the Parts Drawing. When contacting the Simplex Service Department always have your work order and drawing number ready for reference. The Load Bank Specifications Sheet in the front of this manual lists all of the drawings included in this manual. The Work Order Number and the Drawing Numbers are also located on each drawing legend. A typical drawing legend and parts list is illustrated at right.

SIMPLEX™		SPRINGFIELD, ILLINOIS
SCALE :	APPROVED BY :	DRAWN BY : LT
DATE : 9/21/10		REVISED :
RESISTIVE LOAD BANK 2000KW,480V,3 ϕ ,60HZ		SATURN 2000 UL POWER DISTRIBUTION
W.O.# 74332-10-43		DRAWING NUMBER 214103B

ITEM	QTY.	PART #	DESIG.	DESCRIPTION
1	246	DWG206941	LR1-LR246	LOAD ELEMENTS 8333W @ 240V POWER-WEB
2	41	13011065	C1-C40 FMC	CONTACTOR 65A, 600V, 3POLE 120VAC COIL
3	4	14026000	CF1-CF4	FUSE 4A, 600V, 200KAIC
4	1	14012000	CF5	FUSE 2A, 600V, 200KAIC
5	2	14016000	CF6 RF1	FUSE 2A, 600V, 100KAIC
6	120	14087000	F1-F120	FUSE 70A, 600V, 200KAIC
7	3	15012000	[CF1-CF6]	FUSEBLOCK 30A, 600V, 2 POLE
8	1	15011000	[RF1]	FUSEBLOCK 30A, 600V, 3 POLE
9	1	12046330	FCB	FAN CIRCUIT BREAKER 100A FRAME, 40A TRIP 3 POLE, 600V
10	1	24827796	DLR	OVERLOAD RELAY 3 POLE, 600V 15-45A ADJUSTABLE
11	1	24829000	DLRX	DLR AUXILIARY CONTACT
12	2	25457670	T1-T2	TRANSFORMER, 750VA 480/240: 240/120V
13	1	25256500	PS	PRESSURE SWITCH, SPDT DIFFERENTIAL SENSING
14	4	25512400	TC1-4	THERMOCOUPLE, TYPE J (FOR EXTS)
15	1	25309650	INTS	INTAKE TEMP SWITCH SPST, OPENS @ 120 DEG F
16	2	25457850A	DCS1-2	DC SUPPLY, 120VAC INPUT 24VDC OUTPUT 60W
17	52	25678500	TB' LD' TB' PLC2' TB' PLC1 TB' R1', TB' DC1-2' TB' CP', TB' CFR'	TERMINAL BLOCK TERMINAL SEGMENTS,

APPENDIX A - ABBREVIATIONS USED IN THIS MANUAL

Listed below are abbreviations of terms found on Simplex Load Bank Systems. When following a load bank drawing utilize this guide to define abbreviated system and component names. As this is a master list, drawings and text pertaining to your equipment may not contain all these terms.

AC-Alternating current

AIC-Ampere interrupting current-maximum short circuit fault current a component can safely interrupt

AM-Ammeter

AMSW- Ammeter selector switch-selects any phase for current reading

CF-Control fuse

CFM-Cubic feet per minute-used to rate fan air flow capacity and load bank cooling requirement

CFR-Cooling failure relay-normally energized relay in cooling failure subsystem

CPC-Control power contactor

CPF-Control power fuse

CT-Current transformer- used in metering circuits

DC-Direct current

EXTS-Exhaust air temperature switch

FCB-Fan circuit breaker-circuit breaker in series with fan control power

FCVR-Fan control voltage relay-normally energized relay on relay sub-panel

FM-Frequency meter-monitors frequency of test source

FMC-Fan motor contactor-controls power to fan motor

FMSW-Frequency meter switch

FPS-Fan power switch-used to energize cooling system

GFB-Ground fault breaker

GBTR-Ground breaker tripped relay

HMI-Operator Interface

HVR-High voltage relay

Hz-Hertz-cycles per second, measurement of frequency

IFCV-Incorrect fan/control voltage

INTS-Intake air temperature switch

K-Relay coil/contact designation

KVA-Kilovolt amperes

KVAR-Kilovolt amperes-reactive

KW-Kilowatts

KWM-Kilowatt meter

KWT-Kilowatt meter transducer

LM-Louver motor

LMC-Louver motor contactor

LR-Load resistive element

LX-Load reactive element

L1-Line 1

L2-Line 2

L3-Line 3

MCB-Main circuit breaker

MDS-Main Disconnect Switch

MF-Meter fuse

MLB-Main Load Bus

MOT-Motor

NEMA-National electrical manufacturer's association

ODP-Open, drip-proof-refers to motor enclosure

OVR-Overvoltage relay-relay used in overvoltage failure system, located on relay sub-panel

OLR-Overload relay-used for motor protection

OTR-Overtemperature relay-used in failure system

PF-Power factor-in resistive only loads expressed as unity (1.0), in inductive loads expressed as lagging, in capacitive loads expressed as leading

PAR-Control power available relay-relay energized when control power is available

PFM-Power factor meter

PS-Pressure switch-switch used to detect fan failure

RR-Reset relay

RTM-Running time meter-keeps time log of equipment use.

TB-Terminal block

TDR-Time delay relay-relay which times out before contacts change state

TEFC-Totally enclosed, fan cooled-refers to motor enclosure

TEAO-Totally enclosed, air-over-refers to motor enclosure

UPS-Uninterruptable power source

V-Voltage

VSR-Voltage sensing relay

XCB-Reactive load controlling circuit breaker

APPENDIX B - CALCULATIONS & FORMULAS

The following calculations are used to determine the actual kilowatt load being applied by the Load Bank, when line voltages and currents are known (at 1.0 power factor).

3 Phase

1. Read all three line currents and find the average reading.
2. Read all three line-to-line voltages and find the average reading.
3. Multiply the average current times the average voltage.
4. Multiply the answer of step #3 times the square root of 3 (1.732).
5. Divide the answer of step #4 by 1000. The answer is the actual kilowatts of load being applied by the Load Bank.

Single Phase

1. Determine the line current.
2. Determine the line-to-line voltage.
3. Multiply the line current times the line-to-line voltage.
4. Divide the answer of step #3 by 1000.
5. The answer of step #4 is the actual kilowatts being applied by the load bank.

EXAMPLES

Using line voltages and currents:

3 Phase

Current Readings	Voltage Readings
A ₁ = 249A	V ₁₋₂ = 481V
A ₂ = 250A	V ₂₋₃ = 479V
A ₃ = 254A	V ₃₋₁ = 483V

$$\begin{aligned} \text{Average Current} &= \frac{A_1 + A_2 + A_3}{3} \\ &= \frac{249 + 250 + 254}{3} \\ &= 251\text{A} \end{aligned}$$

$$\begin{aligned} \text{Average Voltage} &= \frac{V_{1-2} + V_{2-3} + V_{3-1}}{3} \\ &= \frac{481 + 479 + 483}{3} \\ &= 481\text{V} \end{aligned}$$

$$\begin{aligned} \text{Kilowatts} &= \frac{\text{Volts} \times \text{Amps} \times 1.732}{1000} \\ &= \frac{481 \times 251 \times 1.732}{1000} \\ &= 209.1\text{KW} \end{aligned}$$

Single Phase

Current Reading: 150A Voltage Reading: 240V

$$\begin{aligned} \text{Kilowatts} &= \frac{\text{Volts} \times \text{Amps}}{1000} \\ &= \frac{150 \times 240}{1000} \\ &= 36.1\text{KW} \end{aligned}$$

The following calculations are used to determine the amount of current when the desired amount of kilowatts is applied at 1.0 power factor.

3 Phase

1. Multiply the desired amount of kilowatts to be applied by 1000.
2. Multiply the operating voltage times the square root of 3 (1.732)
3. Divide the answer of step #1 by the answer of step #2.
4. The answer of step #3 is the average line current with the desired kilowatts applied at 1.0 power factor.

Single phase

1. Multiply the desired amount of kilowatts to be applied by 1000.
2. Divide the answer of step #1 by the operating voltage.
3. The answer of step #2 is the average line current with the desired amount of kilowatts applied at 1.0 power factor.

The following calculations are used to determine a step kilowatt rating at other than a rated voltage. This is accomplished by referencing the load step to a KW value at a known voltage.

1. Determine the new unrated operating voltage.
2. Divide the new operating voltage by the reference voltage.
3. Square the answer of step #2.
4. Multiply the answer of step #3 times the reference kilowatt value of the load step which the new kilowatt rating is desired.
5. The answer of step #4 is the kilowatt rating of the load step at the new voltage.

EXAMPLES

When desired amount of kilowatts is applied at 1.0 PF:

3 Phase

Applied: 50KW Operating Voltage: 480V

$$\begin{aligned} \text{Amperage} &= \frac{\text{KW} \times 1000}{\text{Volts} \times 1.732} \\ &= \frac{50 \times 1000}{480 \times 1.732} \\ &= \frac{50,000}{831.36} \\ &= 60.1 \end{aligned}$$

Single Phase

Applied: 25KW Operating Voltage: 240V

$$\begin{aligned} \text{Amperage} &= \frac{\text{KW} \times 1000}{\text{Volts}} \\ &= \frac{25 \times 1000}{240} \\ &= \frac{25,000}{240} \\ &= 104.2 \end{aligned}$$

Determining step KW at other than rated voltage:

Applied: 80KW Operating Voltage: 450V
 Rated Voltage: 480V

$$\begin{aligned} \text{Step KW} &= (\text{Oper. Volt.} \div \text{Rated Volt.})^2 \times \text{Applied KW} \\ &= (450 \div 480)^2 \times 80 \\ &= .9375^2 \times 80 \\ &= 70.3 \end{aligned}$$

FORMULAS

		<u>Alternating Current</u>	<u>Direct Current</u>
Kilowatts	1 phase	$\frac{\text{Volts} \times \text{Amps} \times \text{PF}^*}{1000}$	$\frac{\text{Volts} \times \text{Amps}}{1000}$
	3 phase	$\frac{1.732 \times \text{Volts} \times \text{Amps} \times \text{PF}^*}{1000}$	
*Power Factor, expressed as decimal. (Resistive Load Bank PF is 1.0)			
Amperes (KW known)	1 phase	$\frac{\text{KW} \times 1000}{\text{Volts} \times \text{PF}}$	$\frac{\text{KW} \times 1000}{\text{Volts}}$
	3 phase	$\frac{\text{KW} \times 1000}{1.732 \times \text{Volts} \times \text{PF}}$	
KVA	1 phase	$\frac{\text{Volts} \times \text{Amps}}{1000}$	
	3 phase	$\frac{1.732 \times \text{Volts} \times \text{Amps}}{1000}$	
Amperes (KVA known)	1 phase	$\frac{\text{KVA} \times 1000}{\text{Volts}}$	
	3 phase	$\frac{\text{KVA} \times 1000}{1.732 \times \text{Volts}}$	
KVAR	1 phase	$\frac{\text{Volts} \times \text{Amps} \times \sqrt{1-\text{PF}^2}}{1000}$	
	3 phase	$\frac{1.732 \times \text{Volts} \times \text{Amps} \times \sqrt{1-\text{PF}^2}}{1000}$	

APPENDIX C - TORQUE VALUES

FAN BLADES		
FAN PART NO.	BOLT SIZE	TORQUE FT LBS // IN LBS
13820000	SET SCREW	11.7 // 140
13820500	SET SCREW	11.7 // 140
13821000	SET SCREW	8.3 // 100
13822000	1/4 — 20	7.5 // 90
13823000	1/4 — 20	7.5 // 90
13824000	1/4 — 20	7.5 // 90
13825100	1/4 — 20	7.5 // 90
13826000	1/4 — 20	7.5 // 90
13827500	5/16"	13 // 156
13827600	5/16"	13 // 156
13828000	3/8"	24 // 288

MOTORS, BRACKETS, BUS BAR CONNECTIONS		
BOLT/NUT SIZE	GRADE	TORQUE FT LBS // IN LBS
.250 (1/4-20)	Grade 5, dry	8 // 96
.250 (1/4-20)	Grade 2, dry	5.5 // 66
.312 (5/16)	Grade 5, dry	17 // 204
.312 (5/16)	Grade 2, dry	11 // 132
.375 (3/8)	Grade 5, dry	30 // 360
.375 (3/8)	Grade 2, dry	20 // 240
.437 (7/16)	Grade 5, dry	50 // 600
.437 (7/16)	Grade 2, dry	30 // 360
.500 (1/2)	Grade 5, dry	75 // 900
.500 (1/2)	Grade 2, dry	50 // 600
.562 (9/16) & up	Grade 5, dry	110 // 1320
.562 (9/16) & up	Grade 2, dry	70 // 840

CONTACTORS
See torque values on the front of the contactor.

ELEMENTS/TRAYS		
TERM/NUT SIZE		TORQUE INCH LBS
#6	Rod ends	4
#10	Element Conn.	20
1/4-20	High Voltage	Contact Simplex

MAIN LOAD BLOCKS- ALL SIZES		
CONNECTION	WIRE SIZE	TORQUE FT LBS // IN LBS
LOAD SIDE	4-14AWG	2.9 // 35
LINE SIDE	500MCM-4/0	31 // 375
	3/0-4/0	20 // 240
	2/0-6AWG	10 // 120
	8AWG	3.3 // 40

CIRCUIT BREAKERS		
STYLE	WIRE SIZE	TORQUE INCH LBS
Cutler-Hammer 1-Phase	14-10 AWG	20
	8 AWG	25
	6-4 AWG	27
	3-1/0 AWG	45
Merlin Gerin 3-Phase	14-1/0	50

APPENDIX C - TORQUE VALUES CONT'D

FUSEBLOCKS		
MANUF. PART NO.	WIRE SIZE	TORQUE INCH LBS
BM6031SQ, BM6032SQ, BM6033SQ; 600V, 30A	10-18 AWG	20
T60060-2SR 600V, 60A	10-18 AWG	20
T60030-3CR, 600V, 30A T60060-3CR, 600V, 60A 60100-3CR, 600V, 100A	10-14 AWG	35
	8 AWG	40
	4-6 AWG	45
	2-3 AWG	50

MISCELLANEOUS-TERMINALS, METERS, SWITCHES, COILS, RELAYS, XFORMERS	
CONNECTION SIZE	TORQUE INCH LBS
4	5
6	10
8	19
10	31
1/4-20"	66

TAPER-LOCK BUSHINGS	
BUSHING NUMBER	TORQUE
1008, 1108	55 IN LBS
1210, 1215, 1310, 1610, 1615	15 FT LBS
2012	23 FT LBS
2517, 2525	36 FT LBS
3020, 3030	67 FT LBS
3535	83 FT LBS
4040	142 FT LBS
4545	204 FT LBS
5050	258 FT LBS
6050, 7060, 8065	652 FT LBS
10085, 12010	1142 FT LBS

CAM-LOK STUDS	
THREADED STUD	MAXIMUM TORQUE
5/16" – 18	15 FT LBS
1/2" – 13	40 FT LBS

APPENDIX D - TYPICAL LIFT EYE INSTALLATION

TYPICAL LIFT EYE INSTALLATION

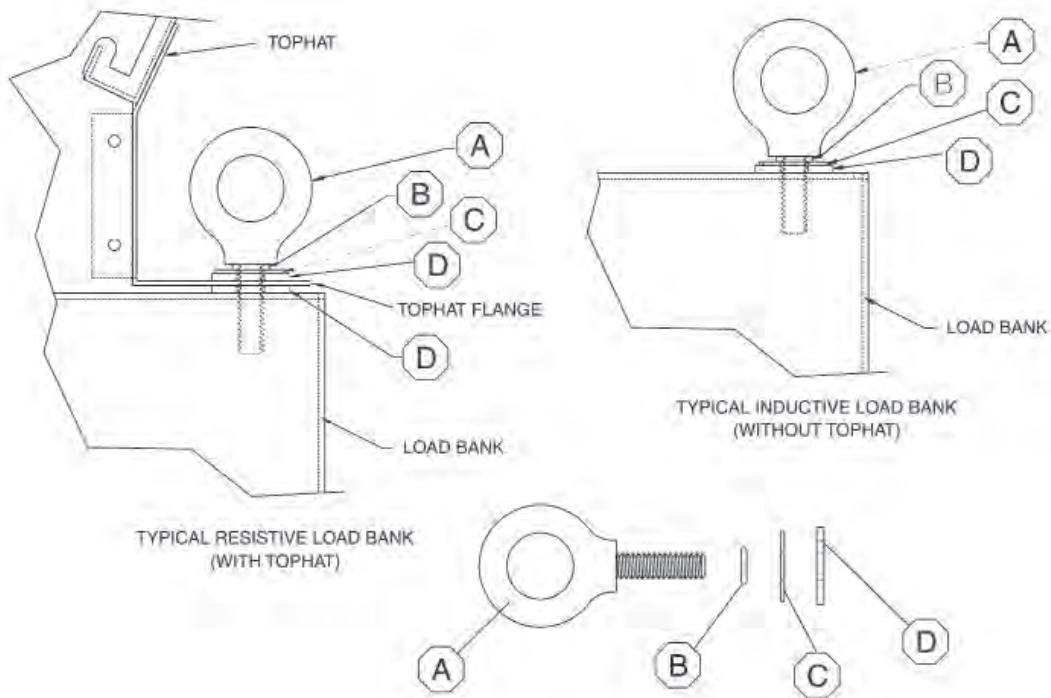

ITEM	DESCRIPTION	1/2"	5/8"	3/4"	7/8"
A	LIFT EYE	15465000	15470000	15471000	15472000
B	O-RING	16750500	16750600	16750610	16750620
C	FLAT WASHER	20424200	20427000	20427100	20427200
D	RUBBER WASHER	20431000	20431001	20431002	20431003

APPENDIX E - SATURN BEARINGS

These instructions pertain to the bearings used on Saturn Load Banks. See Parts Legend Drawing for the specific bearing used for your unit. It is important that these instructions are read in their entirety before attempting installation and removal. The procedures indicated should be carefully followed. Failure to do so can result in improper installation which could cause bearing performance problems as well as serious personal injury.

Bearings In Bolt-On Housings (Units)

1. Check Area - Clean and organize bearing installation area, keep well lighted. Be sure mounting surfaces are clean and flat.
2. Check Shaft - Shaft should be within tolerance range shown in **Table #1**, clean and free of nicks and burrs. Mount bearing on unused section of shaft or repair/replace shafting as required.
3. Install Unit - Slide unit onto shaft. If it is difficult to mount bearing on shaft, use a piece of emery cloth to reduce any high spots on the shaft. Do not hammer on any component of the bearing.
4. Fasten Unit In Place - Install housing mounting bolts, check and align bearing and tighten mounting bolts to recommended fastener torques. Exercising extreme caution and safety, rotate shaft slowly to center bearing.
5. Skwezloc Inserts
 - a) Be sure that the Skwezloc® collar is fitted square and snug against the shoulder on the inner ring.
 - b) Torque the Skwezloc® collar cap screw to torque recommended in **Table #2**.
6. Monitor Installed Bearing* - After bearing has been run for several minutes, and again after several hours, check bearing for excessive noise or vibration. Shutdown machine and check housing temperature: typical applications operate at 100°F – 150°F (38°C – 66°C) (Similar feel to household hot tap water temperature). Tighten all locking devices after 500 hours or 3 months, whichever ever comes first.

TABLE #1 - SHAFTING

Shaft Diameter	Shaft Tolerance
2–3 3/16 in. (50–80 mm)	+0 to -0.0010 in. (+0 to -.25 mm)

TABLE #2 - SKWEZLOC® COLLAR TIGHTENING

English Screw Size	Hex Size	Torque	
		(in-lbs.)	(N-m)
#8-32	T-25	65 – 70	7 – 8
#10-24	T-27	90 – 100	10 – 11
1/4-20	T-30	220 – 240	25 – 27
5/16-18	T-45	450 – 495	51 – 56

APPENDIX E - SATURN BEARINGS CONT'D

Relubrication Instructions

Sealmaster® GoldPlex™-HP has been developed based on the performance characteristics of Sealmaster® brand bearings. Sealmaster® brand bearings are factory filled with GoldPlex™-HP and do not need to be greased upon initial installation. GoldPlex™-HP lithium complex base, petroleum oil, NLGI grade 2 consistency. If not using GoldPlex™-HP grease, **Table #3** is given as a very general recommendation for typical lithium or lithium complex, petroleum oil, NLGI#2 greases. Contact the grease supplier for a more specific lubrication schedule.

Relubricatable SealMaster® brand bearings are supplied with grease fittings or zerks for ease of lubrication with hand or automatic grease guns. Always wipe the fitting and grease nozzle clean. For safety stop rotating equipment. Add one half the recommended amount shown in **Table #4**. Start bearing, and run a few minutes. Stop bearing and add the second half of the recommended amount. A temperature rise, sometimes 30°F, after relubrication is normal. Bearing temperatures should not exceed 250°F (121°C). For any applications that are not in the ranges of the table, contact Sealmaster® for suffix modified bearings that can handle temperatures up to 400°F (204°C).

Note: The tables on this page state general lubrication recommendations based on our experience and are intended as suggested or starting points only. For best results, specific applications should be monitored regularly and lubrication intervals and amounts adjusted accordingly.

TABLE #3 - LUBRICATION SCHEDULE FOR SEALMASTER® GOLDPLEX™-HP

Contamination Level - Clean to Light	
Bearing Temperature	500 RPM to 1000 RPM
-50°F to -30°F	12-24 Months
-30°F to 120°F	12-24 Months
120°F to 180°F	6-12 Months
180°F to 250°F	3-6 Months
Contamination Level - Medium	
Bearing Temperature	500 RPM to 1000 RPM
-50°F to 120°F	1 Week - 1 Month
120°F to 250°F	Daily - 2 Weeks
Contamination Level - Heavy	
Bearing Temperature	500 RPM to 1000 RPM
-50°F to 250°F	Daily - 2 Weeks

TABLE #4 - RECOMMENDED RELUBRICATION GREASE CHARGE

Shaft Size (in.)	Oz.	Shaft Size	Grams
2 to 2 7/16	0.30	55-60	8.51

Compatibility of grease is critical, therefore, if not using Sealmaster® GoldPlex™-HP, consult your grease supplier to ensure compatibility. GoldPlex™-HP is a lithium complex base grease, petroleum oil, NLGI grade 2 consistency.

APPENDIX E - SATURN BEARINGS CONT'D

Application Assistance:

Please contact Application Engineering at:

Phone: (219) 465-2211

Fax: (219) 465-2263

Email: sealmaster.engineering@emerson-ept.com

Sealmaster® brand ball bearings now incorporate a unique, color-coding system to help identify the type of grease in the bearings. Each relubricatable Sealmaster® brand bearing features colored fitting cap to help indicate the type of grease used in the individual bearings. Below is a list of the colored fitting caps and the type of grease they represent.

Yellow - Yellow grease fitting caps indicate that bearings are filled with Sealmaster® GoldPlex™-HP high performance mounted bearing grease.

Red - Red grease fitting caps indicate that bearings are filled with factory standard high-temperature grease. (Lithium complex base with synthetic hydrocarbon oil)

White - White grease fitting caps indicate that bearings are filled with factory standard good grade grease. (Aluminum complex with synthetic oil)

Black - Black grease fitting caps indicate that bearings are filled with a non-standard grease.

AUTOMATIC LOAD APPLICATION

Warning: When Load Bank is in Automatic Mode the fan may start and stop without notice.

1. Start-up generator or bring other test source on line.
2. Adjust power source voltage and frequency.
3. Press the “Automatic Load” button.
4. Press the “Automatic Setup” button to open the Automatic Load Application Setup screen.
5. Enter the desired values and press the “Back” button.
6. Press the “Start” button to initiate automatic operation.



WARNING

When Load Bank is in Automatic Mode the fan may start and stop without notice.

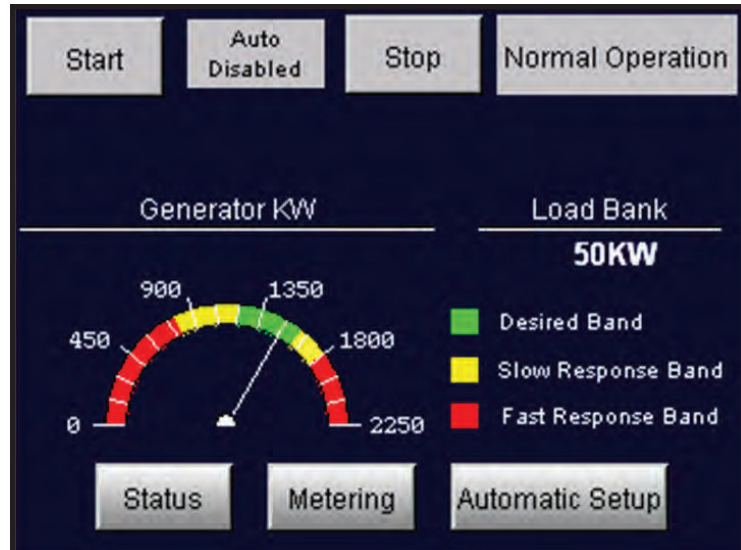

Automatic Load Application Screen

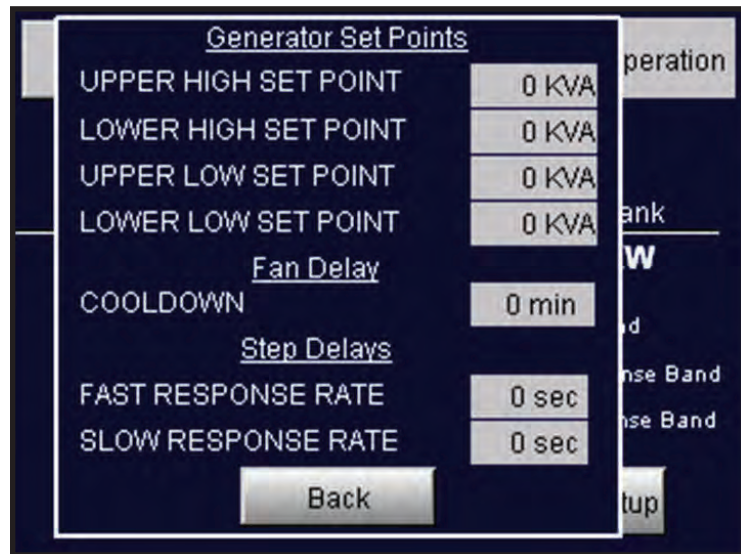

Automatic Setup Screen