

Reliant Series Fuel Tanks

Day Tanks • Filtration Tanks • Specialty Tanks



The Simplex Reliant Series is the latest design expression of a seventy year history of innovation and reliability from the originator of the factory packaged day tank. Today, operating from a new and modern production facility, and with a staff of experienced, capable engineers, service technicians, and production team members, Simplex continues as the standard for design, product and service excellence.



Overview

- High reliability design systems fuel tanks for use as day tanks, main supply tanks, transfer tanks, return tanks
- Integrated, packaged design including tank, gauging, controllers, pumps
- Network compatible with Simplex Fuel Supply System products and with building management systems
- UL142 double-wall secondary containment tanks
- UL2080 double-wall, fire-rated designs
- UL2085 double-wall fire rated, protected designs
- Filtration tank designs
- 10-3000 gallons
- UL508 digital and analog controllers
- Hazardous location constructions available

Description

The Simplex Reliant Series comprises a standard line of Systems Fuel Tanks finding application as day tanks and other tank applications featuring integration of intelligent control with pumping and gauging systems. The Reliant Series is a progressive design evolution of the iconic Simplex Packaged Day Tank Line realizing the latest technology in tank design and construction and use of advanced digital and analog control systems. The Reliant Series is fully compatible for network integration with the full line of Simplex Fuel Supply Systems, including packaged pump systems, tank filling systems, filtration systems, digital fuel and tank management systems and digital monitoring and data systems. The Reliant Series, when supplied with a Simplex digital controller, is MODBUS and Ethernet compatible with most tank gauging systems including Pneumercator, Veeder-Root and Omntec as well as with most Building Management Systems.

Fuel tanks used with the Reliant Series are UL labeled, double-wall secondary containment design, suitable for indoor or outdoor use. Normal duty, rectangular construction tanks are UL142, double-wall secondary containment construction. Cylindrical designs are UL142 double-wall construction. Fire-rated designs are available with UL2080 or UL2085 listings.

Normal duty products are UL508 listed, NEMA1 indoor, NEMA3R, 4, 12 indoor/outdoor. Hazardous location controllers are available.

As a progressive, evolutionary design of the Simplex Packaged Day Tank product line, the Reliant Series finds its core application as a generator day tank. In this traditional application, the Reliant Day Tank integrates a tank of required capacity with a level controller and fill control. On-board fill pumps and return pumps are typical. Remote pumping systems are available for filling of multiple tanks, management of multiple source tanks or when required by pipe run or pump size conditions.

Both digital and analog controllers are available. Digital controllers are PLC based and network compatible. Digital controllers utilize both a point-sensing float switch input and a 4-20mA analog-to-digital input which displays on a panel indicator and provides a 4-20mA output. Analog controllers are based upon the time-proven Simplex SST Controller.

Other applications of the Reliant Series include:

1. Bulk fuel source tanks with pumping systems to transfer fuel to Reliant Day Tanks or to Generator Base Tanks
2. Transfer tanks
3. Return tanks to receive fuel from Reliant Day Tanks or base tanks and pump back to source tanks

In every case, the Simplex Reliant Series achieves a new level of reliability.

1. Double-wall secondary containment tank construction represents the latest in conservative, space saving design
2. Comprehensive hazardous location and fire rated designs integrate tanks with control, pumping and valving systems suitable for the special use intended
3. Purpose built systems integration and network compatibility addresses today's needs for building and systems automation in a developed, standardized design
4. Advanced digital control systems feature system redundancy and self-checking
5. Traditional analog control systems feature time-proven, conservative design

Features

- Double-wall secondary containment tank construction, UL listed
- Digital or analog controllers, UL listed
- Local or remote pumping options, 2-50GPM, 0.33 – 5.0HP
- Single or duplex, fill or return pumping configurations
- Large option and accessory list
- Highly standardized and time proven design
- Design-build project customization
- Digital controllers network compatible
- Fully compatible with complete Simplex Fuel Supply Systems product line, including pump sets, tank filling systems, tank filtration systems, digital fuel management systems, digital controllers

Tank Construction

All tanks are UL listed as noted, all-welded steel, atmospheric design, suitable for outdoor or indoor installation. Tank finish to 150 gallons is powder-coat white, above 150 gallons white industrial enamel

Standard duty tanks:

- 10-400 gallons, UL142 secondary containment construction, rectangular design,
- 400-5000 gallons, UL142, double-wall construction, cylindrical design,

Fire rated duty tanks

- 10-400 gallons, UL2080 or UL2085 protected design, double wall construction, rectangular design

Digital Controller

- DRS Digital Controller
- UL508 listed
- NEMA 1 or NEMA3R enclosed
- PLC based
- 6-inch touch-panel operator interface, monochromatic standard, color optional
- Dual level sensor input:
 - 4-20mA continuous sensor, analog-to-digital input
 - Point sensing float switches: low, refill start, refill stop, high, plus checkpoint for automatic cross check of sensors
- Leak sensor
- Spare I/O for options and design-build features MODBUS and Ethernet network compatible 4-20mA loop output for tank level
- Operator touch-panel interface functions:
 - HOA switch
 - Test
 - Reset
 - Alarm silence
 - Numeric display of tank level in gallons (liters)
 - Graphic condition display of tank level and pump/status/alarm condition
 - Message indicators for status and alarm, including:
 - Normal operation
 - Pump running (fill, return, single or multiple pumps)
 - Tank filling
 - Low
 - Critical low
 - High
 - Critical high
 - Leak
 - Not in auto
 - Controller failure with specific message
 - Other messages as determined by design build option configuration
- Relay dry contact outputs for the following (10A, SPDT):
 - Low alarms
 - High alarms
 - Leak
 - Not in auto
 - Other alarms as determined by design-build option configuration

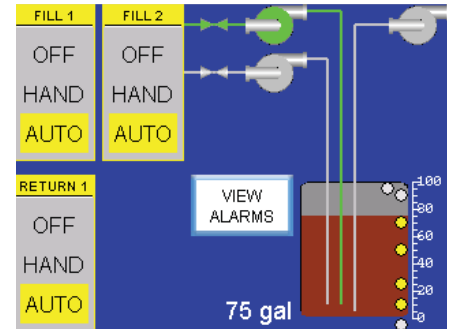

MAIN	NO FLOW ON FILL 1 NO FLOW ON FILL 2 NO FLOW ON RETURN 1 NO FLOW ON RETURN 2 FILL PUMP 1 FAILED FILL PUMP 2 FAILED RETURN PUMP 1 FAILED RETURN PUMP 2 FAILED LEAK DETECTED EMERGENCY STOP FLOAT SWITCH ERROR LOW TANK LEVEL CRITICAL LOW TANK LEVEL CRITICAL HIGH TANK LEVEL ANALOG LEVEL 1 NOT CALIBRATED ANALOG LEVEL 2 NOT CALIBRATED
RESET ALARMS	

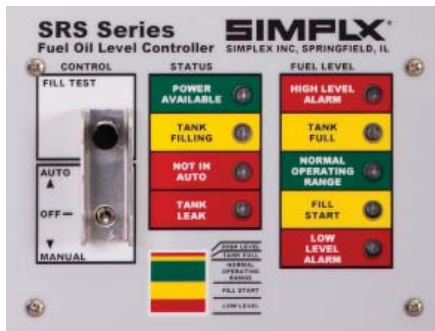

Analog Level Controller

Multifunction liquid level controller:

- Usable with any tank construction
- Versatile mounting
- Accessories to suit a multitude of tank level applications
- Leak detection capability
- UL 508A Listed

The **Simplex Analog Level Controller** is a relay based design, float switch activated, multifunction liquid level controller. SST applications include:

- Single fill pump control
- Duplex fill pump control, level switch activated
- Duplex fill pump control, pressure switch activated
- Single drain pump control
- Duplex drain pump control
- Pump-in, pump-out control

The SST Controller is UL 508A Listed.

The controller is activated by level point sensing float switches.

The standard level transmitter is suitable for use with class-II flammable liquids or water. Optional level transmitters are available:

- Intrinsically safe transmitters for use with Class I liquids
- Alloy or plastic materials for use with corrosive liquids

Consult Simplex for compatibility of materials.



Pumps

Reliant, SRS Series Fuel Tank Systems are available with on-board fill and/or return pumps in single or duplex configuration

Capacity range: 2-50gpm, 0.33 – 5.0HP, single or 3-phase

Simplex SPS OR SKS Series Packaged Pump Sets are used remotely when required by system complexity or pipe-run constraints or where multiple-tank systems are supplied by common pumps

Standard pumps are Parker-Hannifin, advanced technology, hydraulic gear pumps with self-prime maintenance, high-lift capability, linear pressure versus flow output. Construction features machined steel gears, dynamic pressure loaded internal seals, stainless steel shaft, mechanical shaft seal, cast-aluminum housing

Optional pumps are heavy-duty cast iron construction with mechanical shaft seals.

Motors are industrial NEMA size, conservatively rated. All commercial voltage ratings available

Model Numbers

CAPACITY	RATING	DAY TANKS	FILTRATION DAY TANKS	SPECIALTY TANKS
50 Gallons	UL142	SRS-50	SRFT-50	SRX-50
	UL2080	SRS-50 FR	SRFT-50 FR	SRX-50 FR
	UL2085	SRS-50 PT	SRFT-50 PT	SRX-50 PT
75 Gallons	UL142	SRS-75	SRFT-75	SRX-75
	UL2080	SRS-75 FR	SRFT-75 FR	SRX-75 FR
	UL2085	SRS-75 PT	SRFT-75 PT	SRX-75 PT
100 Gallons	UL142	SRS-100	SRFT-100	SRX-100
	UL2080	SRS-100 FR	SRFT-100 FR	SRX-100 FR
	UL2085	SRS-100 PT	SRFT-100 PT	SRX-100 PT
150 Gallons	UL142	SRS-150	SRFT-150	SRX-150
	UL2080	SRS-150 FR	SRFT-150 FR	SRX-150 FR
	UL2085	SRS-150 PT	SRFT-150 PT	SRX-150 PT
200 Gallons	UL142	SRS-200	SRFT-200	SRX-200
	UL2080	SRS-200 FR	SRFT-200 FR	SRX-200 FR
	UL2085	SRS-200 PT	SRFT-200 PT	SRX-200 PT
275 Gallons	UL142	SRS-275	SRFT-275	SRX-275
	UL2080	SRS-275 FR	SRFT-275 FR	SRX-275 FR
	UL2085	SRS-275 PT	SRFT-275 PT	SRX-275 PT
325 Gallons	UL142	SRS-325	SRFT-325	SRX-325
	UL2080	SRS-325 FR	SRFT-325 FR	SRX-325 FR
	UL2085	SRS-325 PT	SRFT-325 PT	SRX-325 PT
400 Gallons	UL142	SRS-400	SRFT-400	SRX-400
	UL2080	SRS-400 FR	SRFT-400 FR	SRX-400 FR
	UL2085	SRS-400 PT	SRFT-400 PT	SRX-400 PT

UL142 Secondary Containment

UL2080 Fire-Rated

UL2085 Fire Protected

Greater than 400 gallons contact Simplex.

Reliant Series

Day Tanks • Filtration Tanks • Specialty Tanks • Page 6

SIMPLEX®

Standard UL142 Day Tank Dimensions

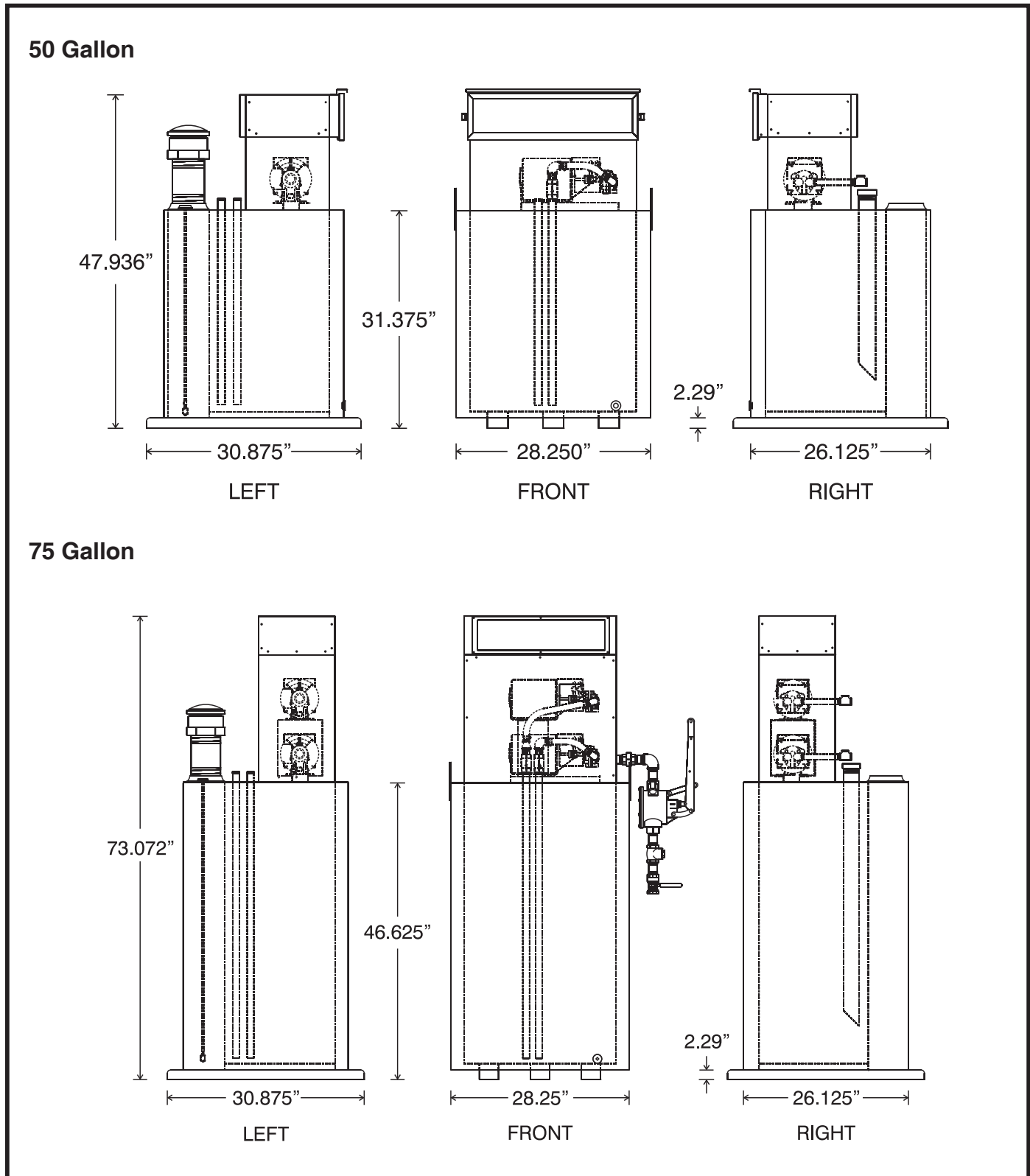

Standard UL142 Day Tank Dimensions

100 Gallon

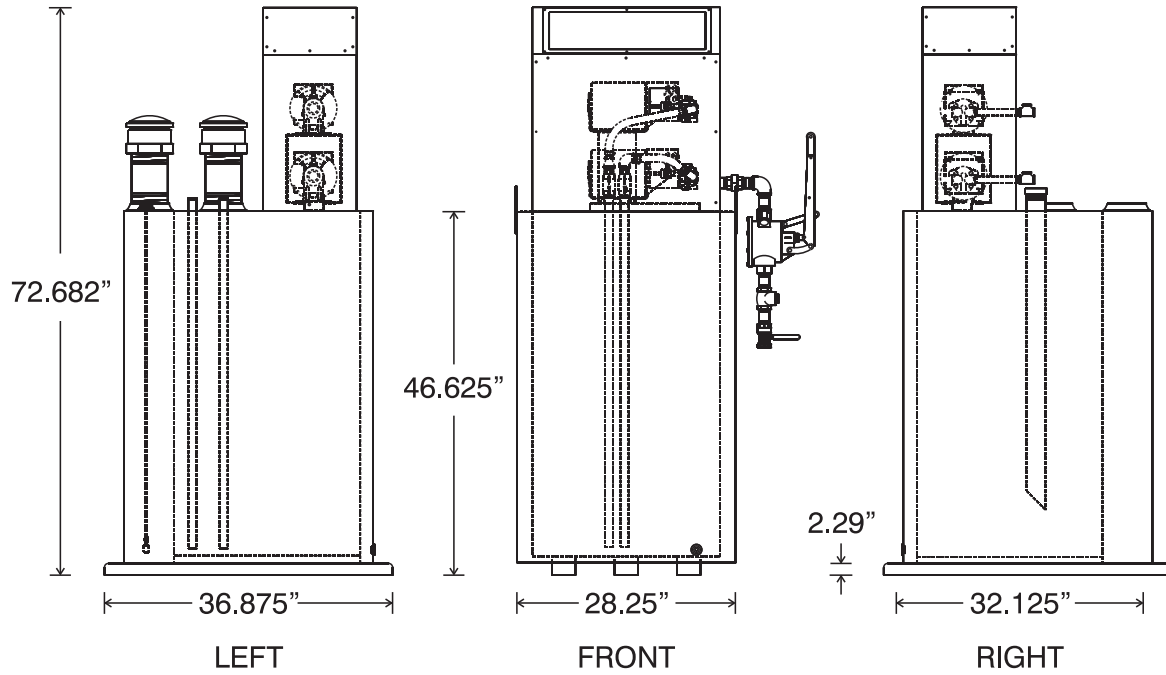

150 Gallon

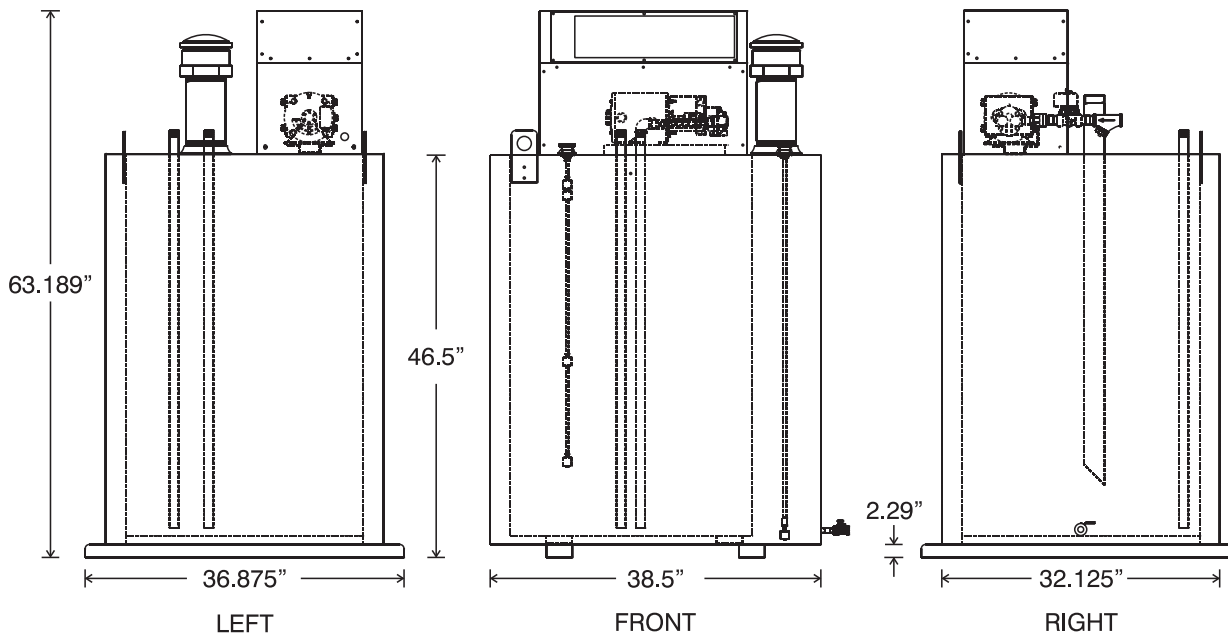

Standard UL142 Day Tank Dimensions

200 Gallon

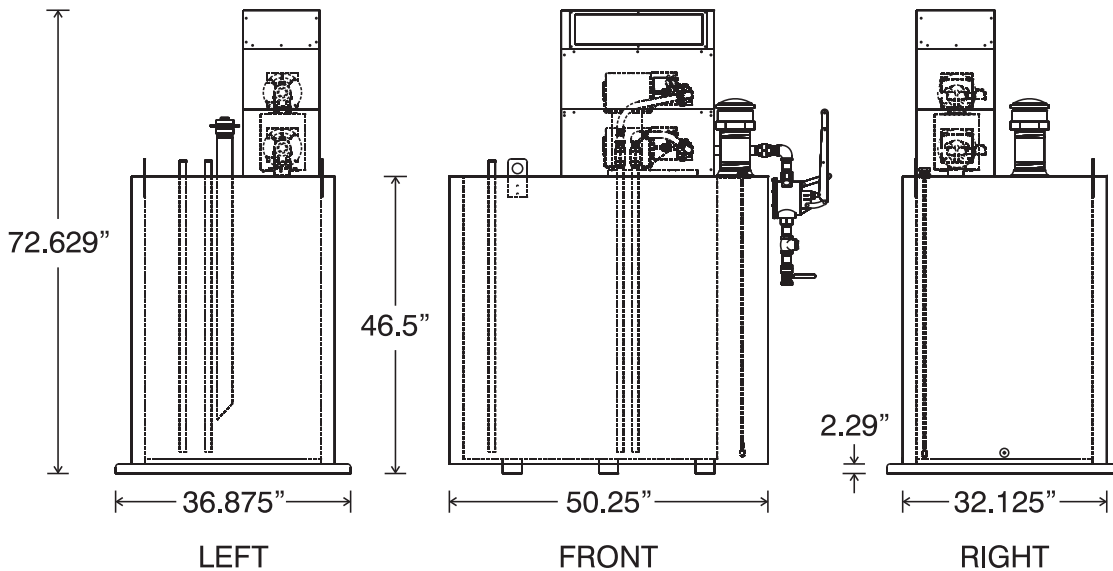

275, 325 & 400 Gallon

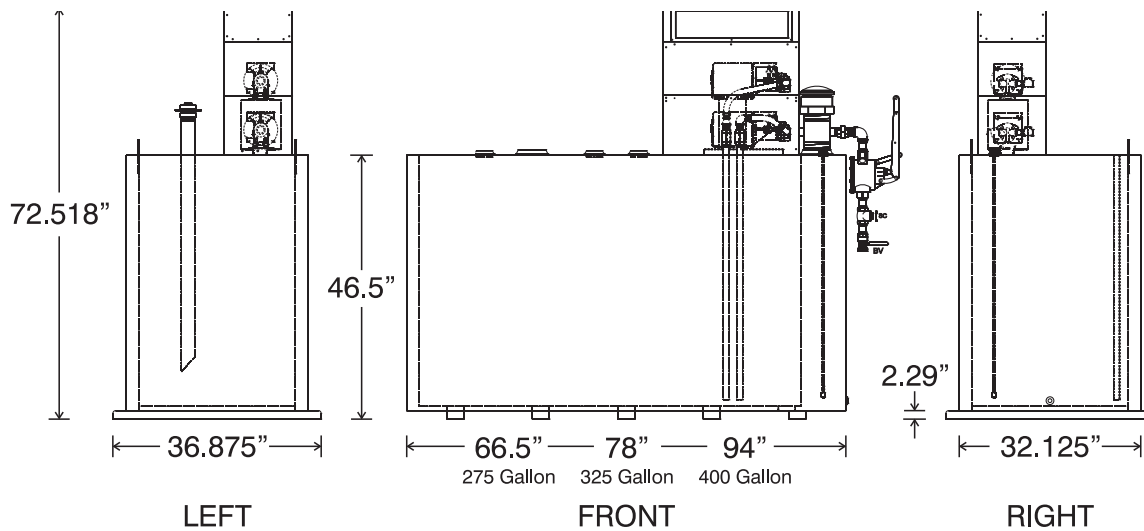

Tank Fittings

Typical Layout

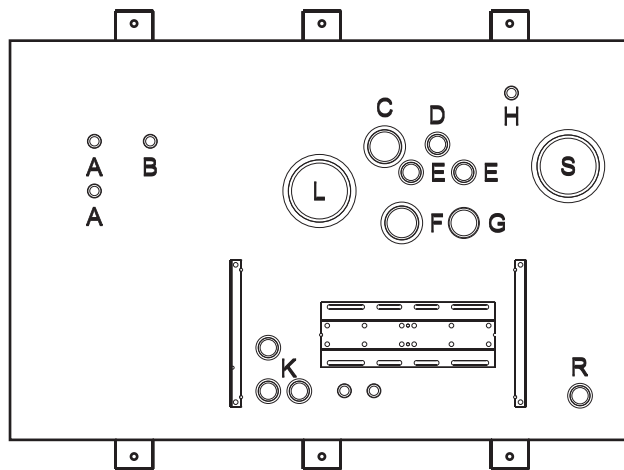

Typical Standard Fittings

Port	Description	Size
A	Engine Supply Drop Tube	0.75" NPT, Male
B	Siphon Drain Drop Tube	0.75" NPT, Male
C	Overflow Port	2.00" NPT, Female
D	Engine Return Port	1.00" NPT, Female
E	Extra Pipe Flange	1.00" NPT, Female
F	Tank Vent Port	2.00" NPT, Female
G	Manual Fill Drop Tube	2.00" NPT, Male
H	Hand Pump Mounting Drop Tube	0.75" NPT, Male
J	Pump Connection To Tank Drop Tube	0.75" NPT, Female
K	Floatswitch MTG/Inspection Port	1.00" NPT, Female
L	Emergency Tank Vent	4.00" NPT, Female
M	Containment Basin Drain	0.50" NPT, Female
R	Containment Basin Leak Sensor Port	1.00" NPT, Female
S	Emergency Containment Vent	4.00" NPT, Female

OPTIONS

MECHANICAL

- 010 Auxiliary hand pump
- 015 Auxiliary hand pump
- 025 Locking manual fuel fill cap
- 040 Wall-mounting brackets
- 050 Pipe stand adapter
- 060 Fuel strainer
- 062 Duplex strainer
- 063 Vent cap
- 064 Emergency vent
- 065 Drain hand valve
- 070 Check valve/priming tee assembly
- 080 Solenoid valve
- 083 DC Solenoid Valve
- 087 Manual fuel shut-off valve, bronze
- 088 Manual fuel shut-off valve, fire-rated
- 090 Foot valve
- 093 Fusible link valve
- 095 Pressure relief valve
- 100 Pressure gauge
- 101 Vacuum gauge
- 102 Compound gauge
- 103 Flow gauge
- 104 Flow indicator sight glass
- 105 Temperature gauge
- 120 Extra 1" pipe connection
- 125 Extra engine suction standpipe
- 130 Oversize pipe connections, 1 1/4" to 2 1/2" NPT
- 131 Oversize pipe connections, 3" to 6" NPT
- 140 Special paint colors
- 141 Epoxy primer, centurian finish
- 180 Weatherproof modification

CONTROL DEVICES & ALARMS

- 191 Float switch in rupture basin w/ alarm
- 260 Disconnect switch
- 261 System circuit breaker
- 262 Control power transformer
- 265 Tank heater
- 270 Power available green pilot light
- 280 Operation mode selector
- 285 Loss of flow alarm
- 295 Remote low fuel level alarm
- 297 Remote high fuel level alarm
- 299 Auxiliary relay
- 311 Local/remote low fuel level alarm
- 312 Local/remote high fuel level alarm
- 325 High fuel level emergency pump stop switch

- 326 High level cut-out
- 329 Low fuel level red light
- 333 Critical low fuel alarm
- 334 Alarm horn
- 340 Running Pump amber light

DUPLEX PUMP SYSTEMS

- 345 Duplex pump controller
- 346 Two running time meters
- 347 Manual duplex pump selector switch

GRAVITY FED DAY TANKS

- 376 Manual reset, normally open solenoid valve
- 377 Siphon-break solenoid valve
- 378 Anti-siphon valve, 2"
- 383 Automatic pump-out conversion
- 390 Fuel rise pump-out control

FUEL OIL COOLERS

- 396 Radiator, fan, flow switch

PUMPS & MOTORS

- 400 7 GPM cast aluminum pump
- 410 10 GPM cast aluminum pump
- 415 17 GPM cast aluminum pump
- 417 25 GPM cast aluminum pump
- 501 1 GPM cast iron pump
- 503 2 GPM cast iron pump
- 505 3 GPM cast iron pump
- 510 10 GPM cast iron pump
- 520 17 GPM cast iron pump
- 530 25 GPM cast iron pump
- 540 35 GPM cast iron pump
- 605 1/3 HP, 230V AC, 1ø, 60Hz motor, ODP
- 615 1/3 HP, 110V AC, 1ø, 50Hz motor, ODP
- 616 1/3 HP, 220V AC, 1ø, 50Hz motor, ODP
- 621 1/3 HP, 230/460V AC, 3ø motor, ODP, w/starter
- 622 1/3 HP, 230/460V AC, 3ø motor, TEFC, w/starter
- 630 1/3 HP, 12V DC motor
- 635 1 1/3 HP, 24V DC motor
- 645 1/3 HP, 115V AC, 1ø, 60Hz, motor, TEFC
- 700 1/2 HP, 115V AC, 1ø, 60Hz motor, ODP
- 705 1/2 HP, 230V AC, 1ø, 60Hz motor, ODP
- 715 1/2 HP, 110V AC, 1ø, 50Hz motor, ODP

- 716 1/2 HP, 220V AC, 1ø, 50Hz motor, ODP
- 721 1/2 HP, 230/460V AC, 3ø motor, ODP
- 722 1/2 HP, 230/460V AC, 3ø motor, TEFC, w/starter
- 730 1/2 HP, 12V DC motor
- 735 1/2 HP, 24V DC motor
- 745 1/2 HP, 230/115V AC, 1ø, 60Hz motor, TEFC
- 768 Single phase magnetic motor starter
- 770 3-phase magnetic motor starter
- 800 3/4 HP, 115V AC, 1ø, 60Hz motor, ODP
- 805 3/4 HP, 230V AC, 1ø, 60Hz motor, ODP
- 825 3/4 HP, 230/460V AC, 3ø, 60Hz motor, ODP, w/starter
- 900 1 HP, 115V AC, 1ø, 60Hz motor, ODP
- 905 1 HP, 230V AC, 1ø, 60Hz motor, ODP
- 925 1 HP, 230/460V AC, 3ø, 60Hz motor, ODP, w/starter

Optional motors requiring SPS/SKS Pump Set when used with 10 through 400 gallon models

- 1000 1 1/2 HP, 115V AC, 1ø, 60Hz motor, ODP
- 1005 1 1/2 HP, 230V AC, 1ø, 60Hz motor, ODP
- 1025 1 1/2 HP, 230/460V AC, 3ø, 60Hz motor, ODP, w/starter
- 1100 2 HP, 115V AC, 1ø, 60Hz motor, ODP
- 1105 2 HP, 230V AC, 1ø, 60Hz motor, ODP
- 1125 2 HP, 230/460V AC, 3ø, 60Hz motor, ODP, w/starter
- 1200 3 HP, 115V AC, 1ø, 60Hz motor, ODP
- 1205 3 HP, 230V AC, 1ø, 60Hz motor, ODP
- 1225 3 HP, 230/460V AC, 3ø, 60Hz motor, ODP, w/starter
- 1305 5 HP, 230V AC, 1ø, 60Hz motor, ODP
- 1322 5 HP, 230V AC, 3ø, 60Hz motor, TEFC
- 1325 5 HP, 230/460V AC, 3ø, 60Hz motor, ODP, w/starter
- 1405 7 1/2 HP, 230V AC, 1ø, 60Hz motor, ODP
- 1422 7 1/2 HP, 208V AC, 3ø, 60Hz motor, ODP
- 1425 7 1/2 HP, 230/460V AC, 3ø, 60Hz motor, ODP, w/starter

ENGINEER'S SPECIFICATION

Sample specification for UL-142 double-wall secondary containment construction day tank with on-board supply duplex pumps drawing from a remote main source tank.

The following defines a day tank with a duplex pump system designed for delivery of fuel from a source storage tank to a day tank, approximately 200-foot horizontal and within 18-feet of vertical lift from the lowest point via a pump set installed on the day tank. At this site, consideration must be given to suction lift characteristics of pumps: this system will operate in the suction lift capability curve of the pumps. Therefore, pipe size of both supply and return lines is paramount to both reduce friction in the supply line and allow for free flow return of fuel in the return line. A foot valve is required in this system if source tank is below day tank. If source tank is below day tank, manual priming is required. Once primed, the system remains so from the foot-valve on the supply line in the main source tank to the inlet of the day tank mounted supply pumps.

A full flow overflow return pipe from each day tank back to the bulk source tank must be provided. Working vents to outdoors must be provided as well as an emergency vent for tanks 100 gallons and larger. If source tank is located above the level of the day tank, an overflow return pump and inlet solenoid is required. See below.

Fuel Oil Day Tank

1.0 General: Provide a packaged design fuel oil day tank for each prime mover. Day tank shall be complete in all respects in order to provide the prime mover with a reliable, local source of fuel. Day tank shall be for use with main tank and fuel delivery system described above in order to provide an automatic, self-refilling fuel supply system.

1.1 The day tank shall be designed and supplied as an engineered system by the manufacturer. Each tank shall be of packaged design to include all inlet flow control devices, other valves, level controls, pump control, indicators, alarms and all other devices as required to form an integrated, functional system such that field installation is restricted largely to external piping, wiring and such intermediate devices that are required by code and/or good engineering practice to interconnect the bulk source of supply to the day tank, the day tank to the prime mover and to provide for external vents as per local codes and UL142, NFPA31 and NFPA37.

1.1.1 The system shall be for use with fuel oil as described by NFPA321, "Basic Classification of Flammable and Combustible Liquids". As defined by this standard, the fuel supply system shall be for use with "combustible liquids", those having a flash point at or above 100°F and further defined as class II or class III liquids. In no case shall a liquid defined as "flammable", or as "class I" or as having a flash point less than 100°F be used. In every case, the system shall not be used or applied at a temperature in excess of the flash point of the contents. Electrical equipment used in the system shall be in accordance with NFPA30, section 5-7, wherein it states "For areas where class II or class III liquids only are stored or handled at a temperature below their flash points, the electrical equipment may be installed in accordance with provisions of NFPA70, National Electric Code, for ordinary locations..."

1.1.2 The system shall be designed and installed in accordance with applicable sections of NFPA30, NFPA31, NFPA37, UL80 and UL142. The day tank shall bear the label of Underwriters Laboratories standard 142 and UL508.

1.2 Installation General: The day tank shall be installed adjacent to the prime mover, on the same grade. Install (as shown on the plan drawings, [as detailed herein]) on a housekeeping pad adjacent to the prime mover. Anchor tank to the pad.

1.2.3 Provide schedule 40, ASTM A 53, black iron pipe connections to the day tank as shown. Make all connections to fixed installed pipe with pipe unions to facilitate tank service/removal.

- (1) Supply to day tank, inlet to day tank pump
- (2) Day tank overflow to bulk supply
- (3) Supply and return to prime mover, as recommended by manufacturer.
- (4) Vent sizes shall be as shown and as required by local codes and by UL 142, NFPA31 and NFPA37 as well as project specification requirements.

1.3 Day tank ratings

1.3.1 Capacity: () gallons

1.3.2 Power requirements: ()V AC, single-phase, 60Hertz, 15A dedicated branch circuit

1.3.3 Day tank construction

1.3.3.1 All welded steel atmospheric tank of rectangular, double-wall secondary containment, welded construction built in accordance with codes and standards noted above for indoor use with fuel oil

1.3.3.2 Pipe thread connections shall be provided for fuel oil supply from remote pump set, supply to prime mover, return from prime mover, overflow to main tank, vents, and drain with fire rated ball valve. A weatherproof, screened vent cap shall be provided as a loose item for field installation at the outdoor vent termination. A weighted type emergency vent cap shall be supplied installed on the primary tank and secondary containment emergency vent ports (100 gallon and larger).

1.3.3.3 The tank shall be equipped with a welded steel channel base suitable for bolt attachment to a concrete pad

1.3.3.4 The tank shall have interior corrosion inhibitor to deter corrosion prior to installation and use

1.3.3.5 The exterior of the day tank shall receive a heavy-duty industrial anti-corrosion coating and be finish painted

1.3.3.6 All day tank system components shall be protected by a removable or hinged steel equipment cover.

- 1.3.3.7** Day tank shall be factory leak tested at 3PSI.
- 1.3.3.8** The tank shall be steel double-wall secondary containment construction bearing the UL 142 label. The containment shall be equipped with a leak detector that shall activate the "leak" alarm described below. A drain with fire rated ball valve is to be supplied. The containment shall be equipped with a separate e-vent as required by UL 142.
- 1.3.3.9** Supply fire rated ball valves as follows:
1. Day tank drain
 2. Secondary containment drain
- 1.4** Fuel delivery system: Provide installed upon the day tank, a duplex fuel oil pump and duplex pump controller with automatic alternator for supply of fuel from the main tank to the day tank. This is a suction-lift application: adequate pipe sizes must be used in the system and a foot valve must be installed in the main tank if main is below level of day tank. Manual priming of the system is required.
- 1.4.1** Duplex pumps: (Specify GPM, up to 25GPM) at 1725 rpm, when operating with fuel oil having a viscosity of 32SSU.
- 1.4.2** Direct drive, motor driven pumps coupled via flexible coupling.
- 1.4.3** Motors to be TEFC construction, HP as required for pump at 50 PSI NEMA type B, continuous duty at 40°C, 1725 RPM, 120V AC, 60 hertz, 1.15 service factor
- 1.4.4** Pumps to be directly driven, positive displacement, internal gear type with mechanical shaft seal and cast iron body, machined steel gears.
- 1.4.5** Fire rated shutoff ball valves on pump inlets
- 1.4.6** Pump check valve, spring-type, cast iron construction
- 1.4.7** Flowswitch each pump
- 1.4.8** Suction strainer, cast iron wye type fuel oil strainer on each pump suction
- 1.4.9** Provide a piston type, 0.1 gallon per stroke hand pump installed and piped and equipped with fire-rated shutoff valves.
- 1.4.10** (If source tank is above day tank) Inlet flow control solenoid valve each pump. Stainless steel construction, with fire-rated bypass valve.
- 1.4.11** (If source tank is above day tank) Supply an overflow return pump at 150% minimum capacity, of supply pump and of identical construction. Add overflow return pump controller to paragraph 1.5 below.
- 1.5** Day tank level controller. A UL Listed, integrated design, digital level controller shall be supplied which provides differential level control for activation of pumps, duplex pump alternator, tank level indication, system alarms and manual operating controls. Level controller shall be self-contained as a unit within a NEMA4 enclosure integral with the day tank assembly.
- 1.5.1** PLC based with 6-inch, color, touch-panel operator interface
- 1.5.2** Dual level sensor input:
- 4-20mA continuous sensor, analog-to-digital input
 - Point sensing float switches: low, refill start, refill stop, high, checkpoint for automatic cross check of sensors
- 1.5.3** Leak sensor
- 1.5.4** Spare I/O for options and design-build features
- 1.5.5** MODBUS and Ethernet network compatible
- 1.5.6** 4-20mA loop output for tank level
- 1.5.7** Operator touch-panel interface functions:
- HOA switch
 - Test
 - Reset
 - Alarm silence
 - Numeric display of tank level in gallons (liters)
 - Graphic condition display of tank level and pump/status/alarm condition
 - Message indicators for status and alarm, including:
 - Normal operation
 - Pump running (fill, return, single or multiple pumps)
 - Tank filling
 - Loss of flow
 - Low
 - Critical low
 - High
 - Critical high
 - Leak
 - Not in auto
 - Controller failure with specific message
 - Other messages as determined by design-build option configuration
- 1.5.8** Relay dry contact outputs for the following (5A, SPDT):
- Low alarms
 - High alarms
 - Leak
 - Not in auto
 - Other alarms as determined by design-build option configuration
- 1.6** Day tank testing
- 1.6.1** The day tank shall be supplied with manufacturers test certificates as below Tank test: pressure test, leak proof test and structural integrity/appearance test
- 1.6.1.2** Level controller: operational test of level sensors, level indicator, level control, alarms, backup devices
- 1.6.1.3** Pump: vacuum test, flow test, pressure test, leak proof test, ampere/voltage test, load test, overload test.
- 1.7** Day tank manual
- 1.7.1** The day tank shall be supplied with an illustrated manufacturers manual that includes the following:
- 1.7.1.1** Registration certificate
 - 1.7.1.2** Glossary
 - 1.7.1.3** Equipment list
 - 1.7.1.4** Detailed description of operation
 - 1.7.1.5** Pump specifications
 - 1.7.1.6** Installation instructions
 - 1.7.1.7** Troubleshooting instructions
 - 1.7.1.8** Maintenance instructions
 - 1.7.1.9** Piping diagram
 - 1.7.1.10** Electrical drawing
 - 1.7.1.11** Exploded view parts drawing/parts list
 - 1.7.1.12** Dimensional drawing
 - 1.7.1.13** Warranty card
- 1.8** Supply a manufacturer's 2-year field service warranty which covers all parts and all labor for guarantee of parts and workmanship as specified herein.
- 1.9** The day tank system, shall be designed and manufactured by a single supplier and be a standard product in serial production. The manufacturer shall have at least 10 years experience in the design and manufacture of these products. This system shall be a Model SRS Packaged Design Fuel Oil Day Tank as manufactured by Simplex, Inc., Springfield, Illinois.