

THE INFORMATION HEREON IS THE PROPERTY OF SIMPLEX, INC., AND/OR ITS SUBSIDIARIES. WITHOUT WRITTEN PERMISSION ANY COPYING, TRANSMITTAL TO OTHERS AND USE EXCEPT THAT FOR WHICH IT IS LOANED IS PROHIBITED.
 © 2016 SIMPLEX, INC. ALL RIGHTS RESERVED

PORT	DESCRIPTION	SIZE
A	ENGINE SUPPLY DROP TUBE - (QTY. 2) (1.000 CLEARANCE TO BOTTOM)	0.75" NPT, MALE
B	SECONDARY TANK E-VENT PORT	3.00" NPT, FEMALE
C	OVERFLOW PORT	2.00" NPT, FEMALE
D	ENGINE RETURN PORT	1.00" NPT, FEMALE
E	EXTRA PIPE FLANGE (QTY. 2)	1.00" NPT, FEMALE
F	TANK VENT PORT	2.00" NPT, FEMALE
G	MANUAL FILL PORT W/ BLEED HOLE (6.000 CLEARANCE TO BOTTOM)	2.00" NPT, MALE
H	HAND PUMP DROP TUBE (1.000 CLEARANCE TO BOTTOM)	0.75" NPT, MALE
J	PUMP CONNECTION TO TANK (QTY. 3) (1.000 CLEARANCE TO BOTTOM)	0.75" NPT, MALE
K	FLOATSWITCH MOUNTING PORT (QTY. 3)	1.00" NPT, FEMALE
L	PRIMARY TANK EMERGENCY VENT	3.00" NPT, FEMALE
M	SECONDARY TANK DRAIN PORT	0.50" NPT, FEMALE
N	PRIMARY TANK DRAIN PORT	0.50" NPT, FEMALE
R	LEAK SENSOR PORT	1.50" NPT, FEMALE
S	EXTRA PORT	1.50" NPT, FEMALE

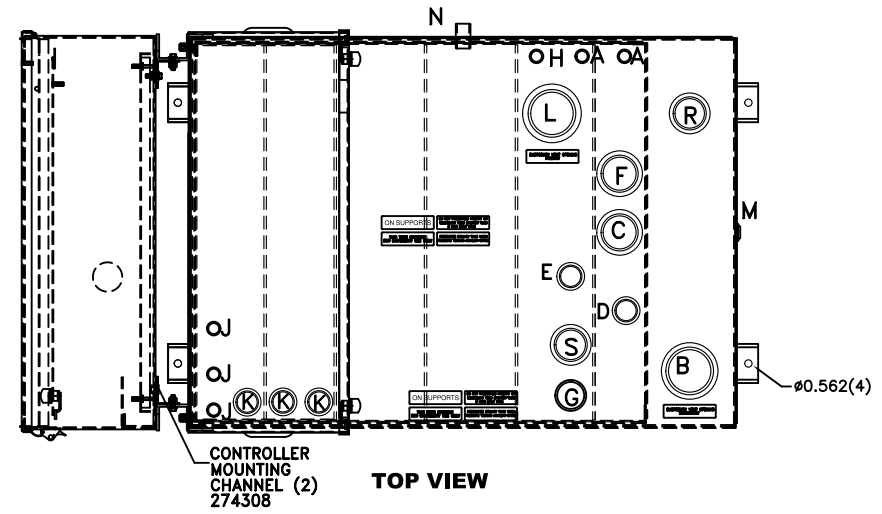

MOTOR MOUNT PLATE (QTY. 3)
273493A

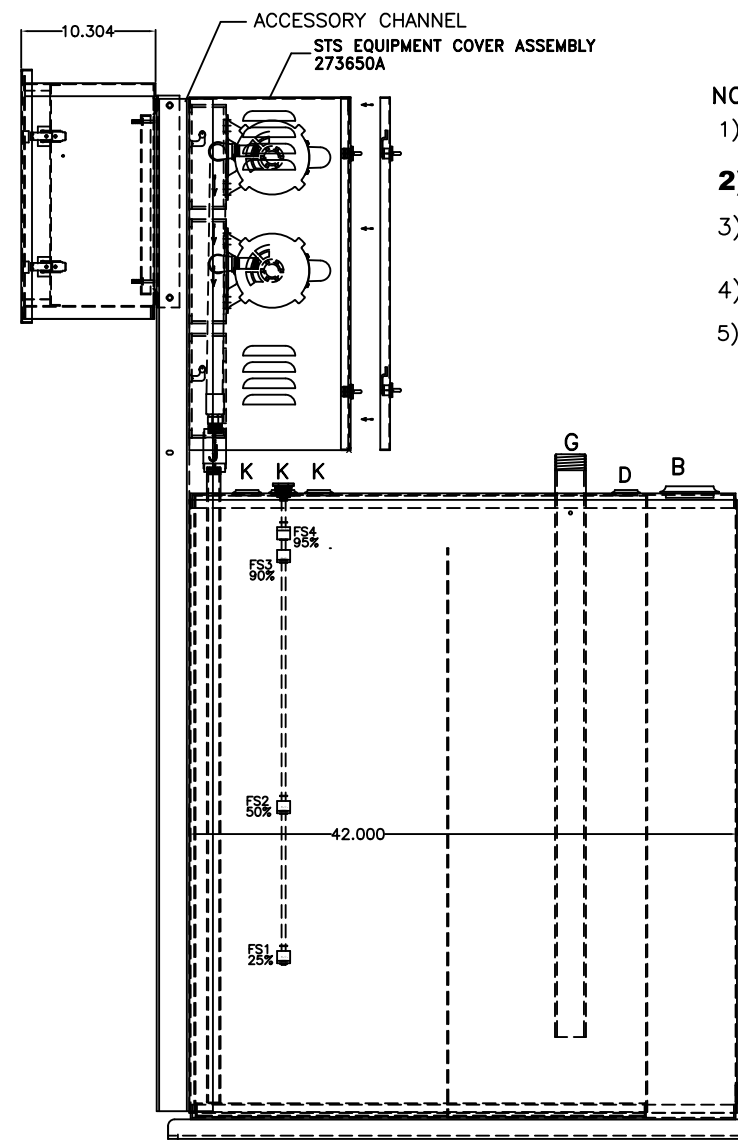
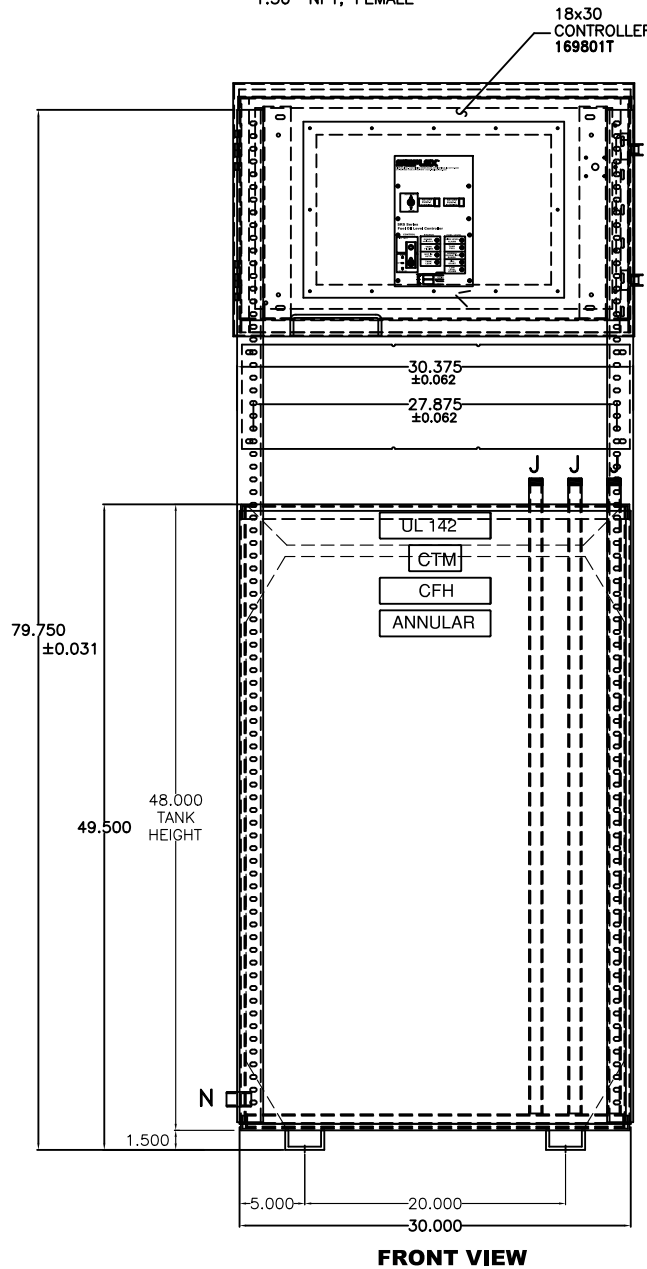
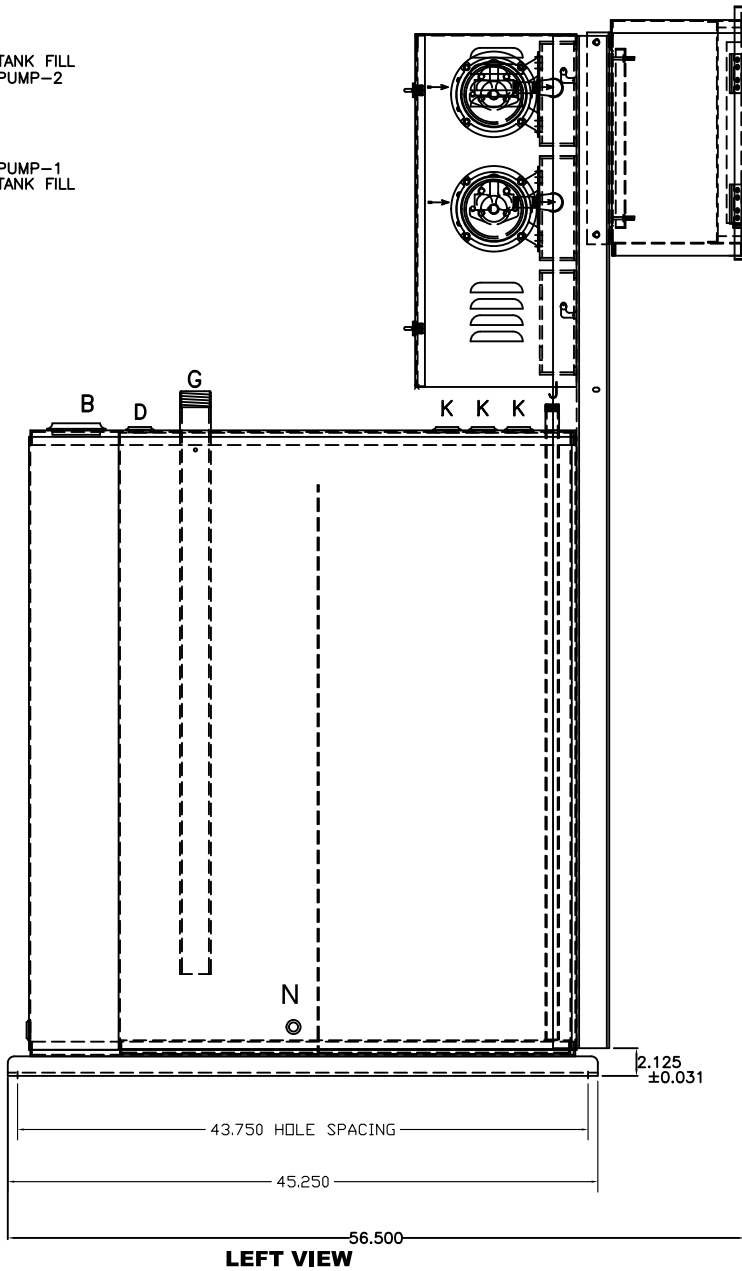
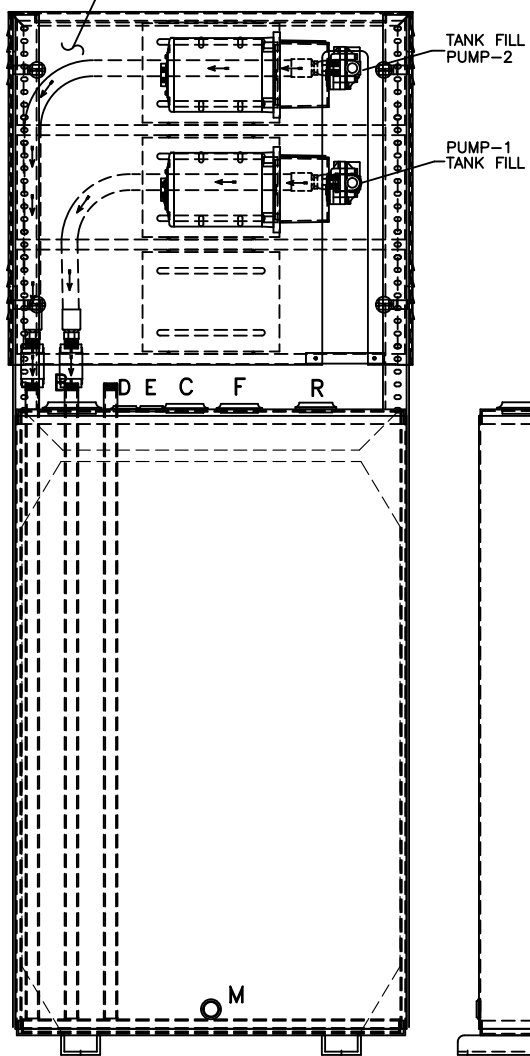

- NOTES:
- 1) CONSTRUCTION: 12 GA. H.R.S.
TANK TOP: 10 GA. H.R.S.
 - 2) LISTING: UL 142
 - 3) RATING: ATMOSPHERIC TANK
TESTED TO 3 PSI
 - 4) ALL DIMENSIONS ±.125"
 - 5) TANK COLOR = SIMPLEX CAROLINA VERMILLION
CONTROLLER COLOR = SIMPLEX COASTAL HAZE

SIMPLEX		SPRINGFIELD, ILLINOIS
SCALE : ~	APPROVED BY :	DRAWN BY : JDS
DATE : 06/29/16		REVISED :
SIMPLEX TECHNOLOGY SERIES		STS 200 GALLON
FUEL OIL DAY TANK		274653