



600V

UL US LISTED

NorthStar

150KW, 600VAC Digital Load Bank with Network Capability

Description

The Simplex NorthStar Portable Digital Load Bank is specifically designed for the Canadian Market by providing 600v capability in an ultra-compact, lightweight, versatile test instrument WHICH CAN BE NETWORKED FOR HIGH AGGREGATE KW. The NorthStar is rated 150kw in steps of 5kw. It is suitable for testing engine generators, wind generators, UPS systems, ground power units, auxiliary power units, static inverters or virtually any other AC power source on the production line, in the service shop or in the field.

The NorthStar is a digitally controlled load bank with network capability. All control is via a hand-held touchscreen controller connected to the load bank via a supplied RS-232 network cable. The load bank includes a digital power transducer with meter displays on the touchscreen. Load is applied via a screen keypad. Any number of NorthStar Load Banks can be networked together via RS-232 cables connected from the "out" connector on the first unit to the "in" connector on the next, and then "out-to-in" in succession until the desired number of units are connected. All control and metering is provided from a single hand-held controller. All instrumentation values for the total network are summed and displayed on the master controller.

The NorthStar is highly portable and easily transported to the job site. The Load Bank includes casters, lifting and moving handles. Power connections are plug-in to Cam-Lok connectors. Control and cooling fan power is obtained from a common 115v, 15A outlet via the included connection cord.

Features

-  Designed for Canada Use: 600VAC, 3-phase, 60Hz
- UL Listed, United States and Canada
- Lightweight and compact
- Portable, self-contained
- "Powr-Web" elements
- Branch circuit fuse protection of load elements
- Magnetic contactor control of load
- Digital load control



1800KW, 600V NorthStar Load Bank system formed by networking 12 NorthStar Units to a single Master Controller.

- Digital Power Transducer, standard: Volts, Amps, Frequency, KW
- 150°C XLP insulated power wiring
- Cam-Lok power connectors
- Operate fan and control circuits from a common 120V wall outlet, 15' cord provided
- Forced air cooled, integral cooling fans
- Fan motors protected by fuses
- Control circuits fused
- Comprehensive malfunction detection system:
 - Overtemperature and fan failure protection
 - Overvoltage protection
- Continuous duty
- NEMA-1 enclosure
- Casters and handles provided

Dimensions and Key Features

1. Control Compartment Cooling Fans (2)
2. Load Element Compartment Cooling Fans (4)
3. Load Source Connections
4. Storage Compartment for handheld controller
5. Handles (2)
6. RS-232 and 120V connectors
7. Swivel Casters (4)

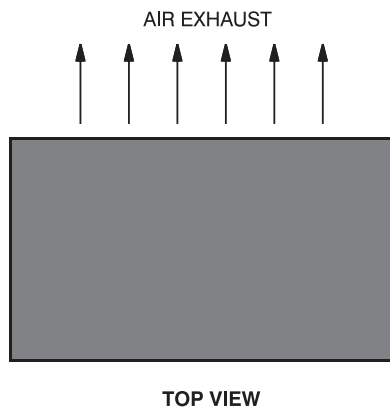

Master Controller

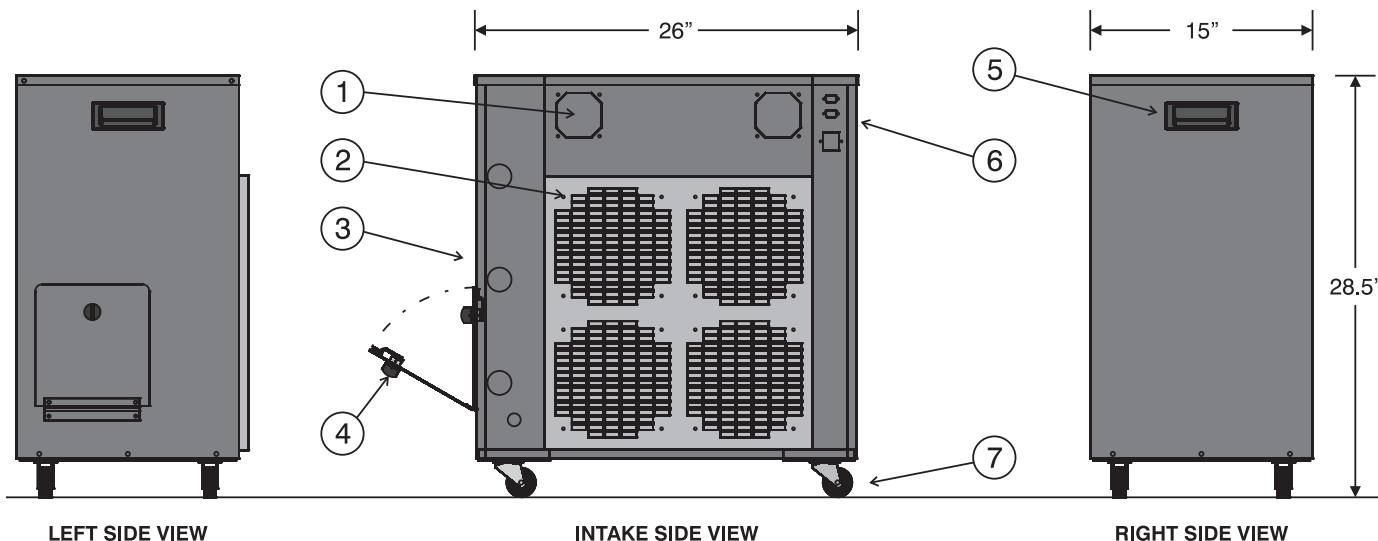

Capacity

150KW; 144FLA

Fan/Control Power

External, 115V, 1-ph., 60Hz, 15A service, 15' cord with plug provided

Voltage

600VAC, 3-phase, 60Hz

Load Steps

Digital load control, 5kw resolution

Frequency

60Hz

Duty Cycle

Continuous
Temp Rating
125° F max intake air temp
Nominal 110°F rise

Weight

125 lbs.

Options

- Vinyl Cover

Network Options

- Junction Boxes to Parallel Multiple Units
- RS-232 Network Cables
- Data Acquisition Recording System

