

*** * WARNING * ***

1. THIS EQUIPMENT IS SUITABLE FOR USE IN CLASS 1 DIVISION 1, GROUP D, HAZARDOUS LOCATIONS OR NON-HAZARDOUS LOCATIONS ONLY.
2. WARNING - EXPLOSION HAZARD - SUBSTITUTION OF COMPONENTS MAY IMPAIR SUITABILITY FOR DIVISION 1, GROUP D, HAZARDOUS LOCATIONS.
3. WARNING - EXPLOSION HAZARD - DO NOT SERVICE THIS EQUIPMENT UNLESS POWER HAS BEEN TURNED OFF OR THE AREA IS KNOWN TO BE NON-HAZARDOUS
4. EXPLOSION PROOF WIRING, CONDUITS, AND VAPOR SEALING BARRIERS REQUIRED. INSTALL PER APPLICABLE NEC & NFPA REQUIREMENTS FOR HAZARDOUS LOCATIONS

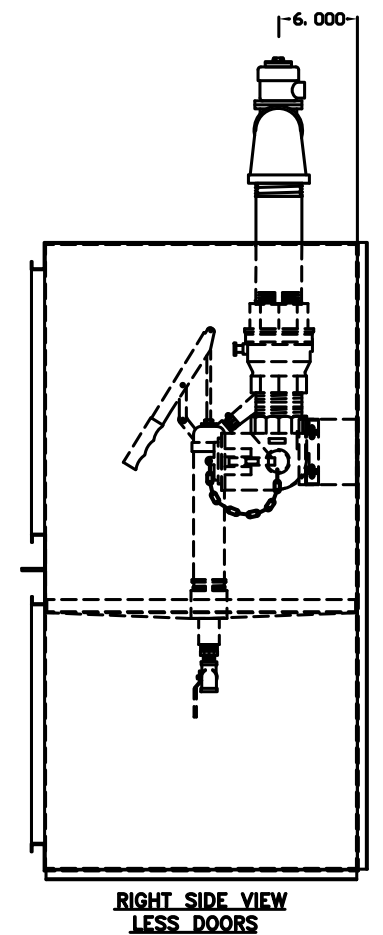
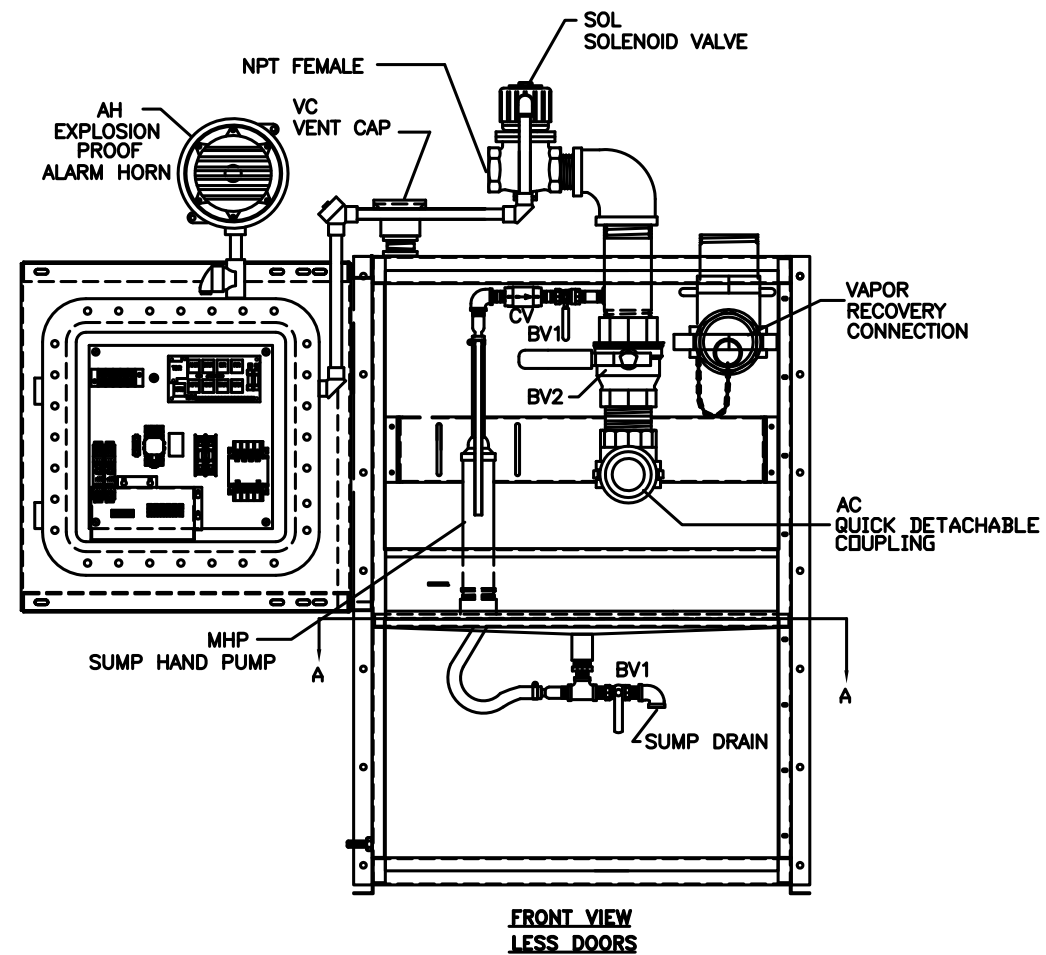
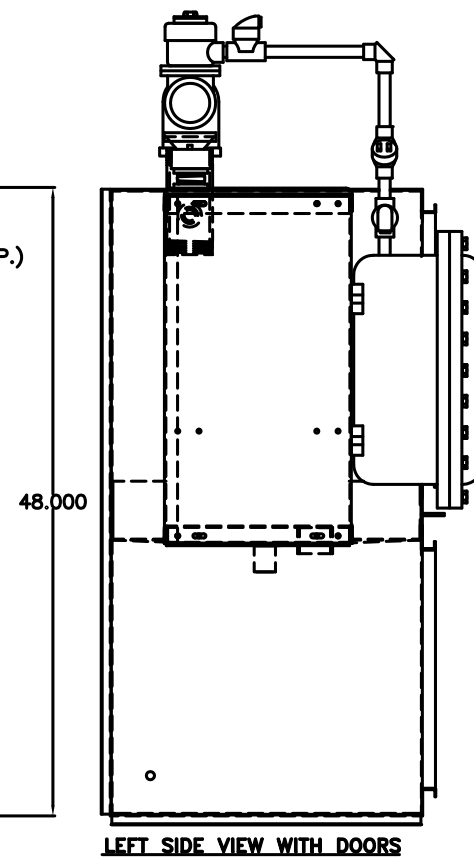
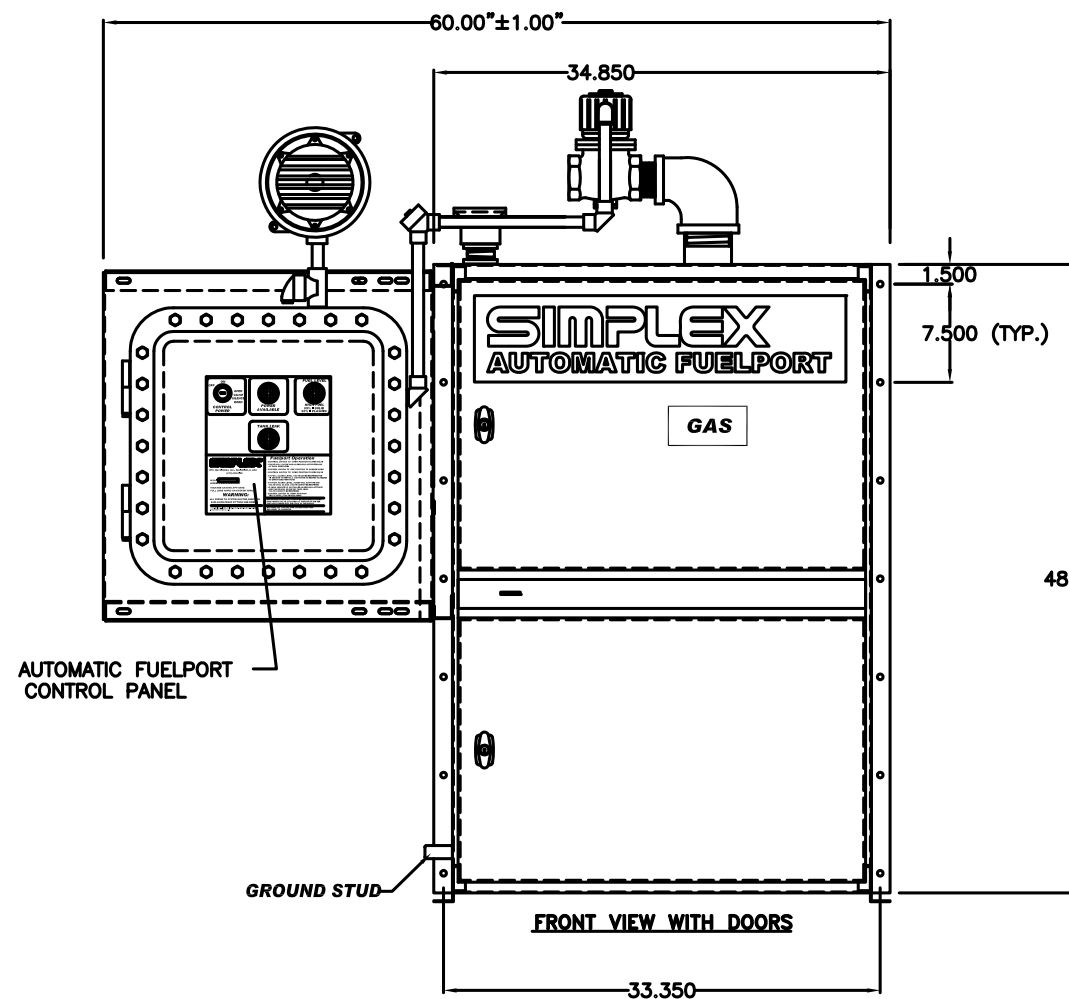

NOTES:

1. CONSTRUCTION: FORMED AND WELDED HOT ROLLED STEEL
2. ALL PARTS CLEANED
3. PAINT: POWDER COAT BONE WHITE
4. ALL ALL DIMENSIONS ± .125"
5. FITTING SIZE: 2", 3" OR 4"

THE INFORMATION HEREON IS THE PROPERTY OF SIMPLEX, INC., AND/OR ITS SUBSIDIARIES. WITHOUT WRITTEN PERMISSION ANY COPYING, TRANSMITTAL TO OTHERS AND USE EXCEPT THAT FOR WHICH IT IS LOANED IS PROHIBITED. DESIGN SUBJECT TO CHANGE WITHOUT NOTICE.
©2010 SIMPLEX, INC. ALL RIGHTS RESERVED.

SIMPLEX		SPRINGFIELD, ILLINOIS
SCALE :	APPROVED BY :	DRAWN BY : RER
DATE : 08-10-10		REVISED :
AUTOMATIC FUELPORT - GASOLINE WITH VAPOR RECOVERY PICTORIAL		
STANDARD		DRAWING NUMBER 211984