

SIMPLEX[®]



Polaris
Resistive Load Bank

This manual was last revised:

June 8, 2021

For up-to-date information on this product or others,
please contact Simplex at 800-637-8603 or
on the web at www.simplexdirect.com.

Table of Contents

I. Polaris Resistive Load Bank	5
I-A. OVERVIEW	5
I-B. WARNINGS AND CAUTIONS	6
I-C. LOAD BANK STRUCTURE	8
I-D. SAFETY	9
I-E. UNPACKING	9
I-F. PRIMARY INSPECTION	9
I-G. INSTALLATION	10
I-G-1. INSTALLATION - PLACEMENT	10
I-G-2. INSTALLATION - PROCEDURE	12
I-G-3. INSTALLATION - INPUT SIGNALS	13
I-G-4. INSTALLATION - CURRENT TRANSFORMERS	13
I-G-5. INSTALLATION - MODBUS COMMUNICATION	14
I-G-6. INSTALLATION - ANTI-CONDENSATION HEATERS	14
I-G-7. INSTALLATION - BMS/BAS SIGNAL CONTACTS	14
II. SIMPLEX LOAD MARSHAL™ CONTROL SYSTEM	15
II-A Navigation	15
II-B. Specific Unit’s Capabilities	16
II-C. User Settings	16
II-C-1. General Settings	16
II-C-2. Auto Load Leveling Settings	17
II-C-3. Backpressure Monitoring (BPM) Settings	18
II-C-4. Miscellaneous Settings	19
II-D. Load Control Modes	20
II-D-1. Control Screens	21
II-D-2. Manual Control	22
II-D-3. Numeric Load	23
II-D-4. Automatic Load Modes	23
II-D-5. Auto Load Leveling	24
II-D-5-a. Auto Load Leveling Operation	25
II-D-5-b. Backpressure Monitoring Option	25
II-D-5-c. Regen (Reverse Power Prevention) Option	26
II-D-6. Auto Trigger Input	26
II-D-7. Auto Exercise	26
II-D-8. Fixed Load	27
II-D-9. Auto Sequence Load	27
II-D-10. Sequence Loading	28
II-E. Data Logging	29
II-F. Options Screen	30

II-G. Step Quarantine	30
II-H. Self-Diagnosis	31
II-I. System Status	31
II-J. Alarms and Warnings	32
II-K. Modbus or 2nd Screen Control/Monitoring.....	33
III. Troubleshooting	37
III-A. Cooling Fan Will Not Start/Operate.....	37
III-B. Fan Failure Indicated.....	37
III-D. High Exhaust Temp Indicated.....	38
III-G. HMI/PLC Comm Errors	38
III-H. Other HMI Issues	38
III-I. Reduced kW Output or Phase Imbalance.....	39
III-J. Meter Comm Error Indicated	39
III-K. Metering Issues.....	39
III-L. Automatic Load Leveling Issues.....	40
IV. Maintenance.....	41
IV-A. Each Operation:.....	41
IV-B. Every 50 Hours or 6 Months, or after transportation:	41
Appendix A - Rated Resistance and Current.....	42
Appendix B- Single Phase Configuration	43
Appendix C - Torque Values	44

I. Polaris Resistive Load Bank

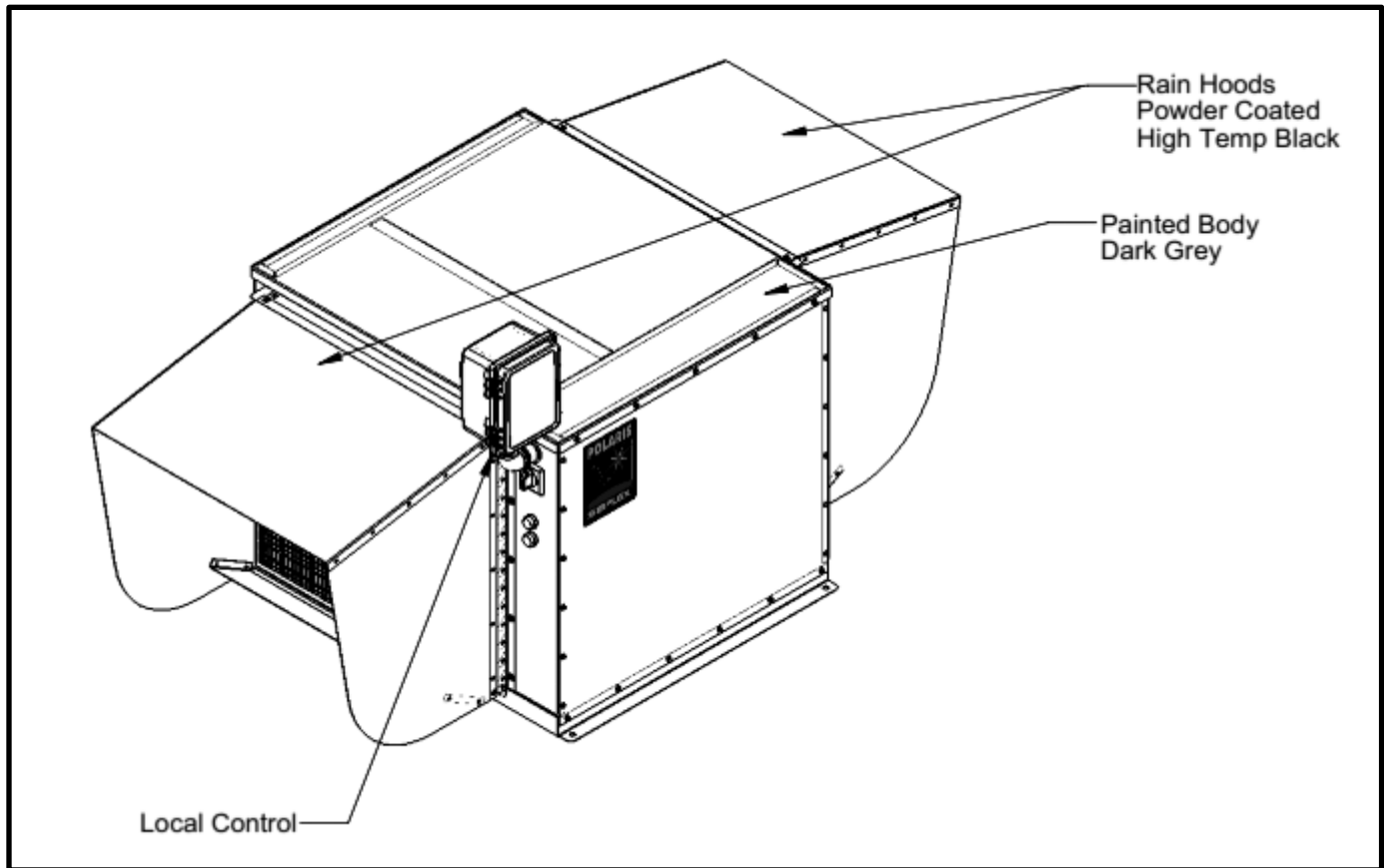

Polaris Load Bank with Optional Local Control Box

I-A. OVERVIEW

Simplex Stationary Load Banks are precision test instruments specifically designed to apply discrete, selectable electrical load to a power source while measuring the source's response. They also provide a means for routine maintenance and exercise of standby power systems to assure long term reliability and readiness of the power system.

Load Banks can also help eliminate the detrimental effects of unloaded operation on diesel engine generators and are often used to balance load and prevent reverse power generation.

Simplex Stationary Load Banks are available in various cabinet designs and capacities. Standard cabinets are rated as Type 3R (outdoor weatherproof) but are also available as Type 1 (indoor rated). If desired, the Load Bank can be mounted on a trailer.

Standard Polaris units are designed to operate in ambient temperatures between 32° and 125°F (0° - 52°C). Units specified and built as Arctic Duty models add features such as cold weather rated wire and motor grease as well as additional heaters to facilitate use in low temperature environments.

The illustrations in this manual are examples only and may differ from any given load bank. For details on specific units, see the drawing package provided with the unit.

I-B. WARNINGS AND CAUTIONS



The **GENERAL** warning symbol points out important information that, if not followed, could endanger personal safety and/or property.



The **EXPLOSION** warning symbol points out potential explosion hazards.



The **FIRE** warning symbol points out potential fire hazards.



The **ELECTRICAL** warning symbol points out potential electrical shock hazards.

The load bank is a high-powered, technical, industrial piece of equipment operating at dangerous voltages and temperatures. It is not a consumer product. It can damage itself, property, and/or personnel if improperly used.

It must be installed, connected, and operated by personnel properly trained and experienced in its use. An operator's manual is supplied with each load bank and available online at www.simplexdirect.com. The operator must be familiar with its contents and have access to it during operation.



HIGH VOLTAGE: Turn off and disconnect power source before opening this equipment.

HIGH TEMPERATURE: Allow hardware to cool before servicing or opening this equipment.



ROTATING EQUIPMENT: Ensure that the fans have stopped before opening this unit.

FOR OPERATOR SAFETY: Make sure this equipment is properly grounded when in use.

The following cautions should be observed before and during operation:



Check intake and exhaust screens as well as fan and load elements for foreign objects. Position and install the load bank with consideration given to large cubic airflow requirements, exhaust temperature, and velocity. Do not point exhaust at any nearby surface or object that may be adversely affected by high temperature. This includes but is not limited to painted surfaces, tar paper, asphalt roofs, water sprinkler heads, fire alarms, and volatile material.



Do not use in confined spaces. The load bank may have to compete with cooling air requirements of a nearby running engine generator set where cooling air intake to a confined space may not be adequate for both engine and load bank. Be especially careful not to bounce hot exhaust air off nearby obstructions for re-circulation through the load bank.



Verify that all control switch positions are set correctly for your intended use before connecting the load bank to the source to be tested.

The load cables carry high amperage. Be constantly aware of the possibility of inductively heating adjacent ferrous objects to temperatures sufficient to damage cable insulation.



Always connect the safety ground cable to a proper ground. Do not rely on a possible grounded neutral somewhere else in the system.

Do not let the load bank run unattended for long periods of time.

Do not store or operate in rain unless adequate protection is provided.

I-B. WARNINGS AND CAUTIONS CONT'D



Routinely inspect all components and electrical connections for tightness and integrity. Repair any damaged or degraded components and wiring without delay.

If technical assistance, service, or parts are needed, please call 800-837-8603 (24 hours).

All hardware covered by this manual has dangerous electrical voltages and can cause fatal electrical shock. Avoid contact with bare wires, terminals, connections, etc.

Ensure all appropriate covers, guards, grounds, and barriers are in place before operating the equipment. If work must be done around an operating unit, stand on an insulated dry surface to reduce the risk of electrocution.

Do not handle any kind of electrical device while standing in water, while barefoot, or while your hands or feet are wet.

If people must stand on metal or concrete while installing, servicing, adjusting, or repairing this equipment, place insulative mats over a dry wooden platform. Work on the equipment only while standing on such insulative mats.

The National Electrical Code (NEC), Article 250, requires the frame to be connected to an approved earth ground and/or grounding rods. This grounding will help prevent dangerous electrical shock that might be caused by a ground fault condition or by static electricity. Never disconnect the ground wire while the load bank is in use.



Wire gauge sizes of electrical wiring, cables, and cord sets must be adequate to handle the maximum electrical current (ampacity) to which they will be subjected.

Before installing or servicing this (and related) equipment, ensure that all power voltage supplies are completely turned off at their source. Failure to do so can result in hazardous and possibly fatal electrical shock.



In case of accident caused by electric shock, immediately shut down the source of electrical power. If this is not possible, attempt to free the victim from the live conductor. **AVOID DIRECT CONTACT WITH THE VICTIM.** Use a non-conducting implement, such as a dry rope or board to free the victim from the live conductor. If the victim is unconscious, render first aid and seek immediate medical attention.

Never wear jewelry when working on this equipment. Jewelry can conduct electricity resulting in electric shock or may get caught in moving components, causing injury.

Always keep a fire extinguisher near the hardware. **DO NOT** use any carbon tetra-chloride type extinguisher as the fumes are toxic and the liquid can deteriorate wiring insulation. Keep the extinguisher properly charged and be familiar with its use. If there are any questions pertaining to fire extinguishers, please consult the local fire department.

The illustrations in this manual are examples only and may differ from your load bank.

Main Disconnect to be provided by installer, rated at 600V maximum, and sized 150% maximum of rated current.



Load Bank warranty is void if incorrectly cooled.

I-C. LOAD BANK STRUCTURE

The Load Bank comprises three principal systems:

1. Control System
2. Cooling System
3. Load System

Control System

Polaris load banks feature a Human-Machine Interface (HMI) touch screen which, in conjunction with a Programmable Logic Controller (PLC), controls the load bank operation and displays the unit's status. With the HMI, the operator can apply a desired load and measure the response of the test source.

Fan/Control Power is supplied to the load bank in one of two ways. An "Internally" powered unit takes its control power from the load bus, while an "Externally" powered unit takes its control power from a separate source. In either case, the voltage is stepped down to 120V control power by a Control Power Transformer and fused with Control Fuses for protection. See the unit's drawing package for more details regarding control power.

The Polaris load bank can be equipped with optional automatic modes, which can extend a power source's life. For more information refer to Section II-D, Load Control Modes.

Simplex load banks can also be integrated into a facility's Building Management/Building Automation System (BMS/BAS) via standard Modbus RS485 or optional Modbus TCP/IP protocol, as well as by a set of dry contacts reporting various unit status points. For more information refer to Section II-K, Modbus Controls.

Cooling System

Polaris load banks are cooled by forced air, delivered by an aluminum fan blade driven by a *TEFC* motor. The motor is energized through a contactor and protected by a circuit breaker and Motor Disconnect Switch.

Air flows horizontally through the Load Bank, through screened intake and exhaust vents.

Optional equipment allows the exhaust to be driven through a customer-installed duct, providing for indoor installation.

Load System

The load system comprises independently controlled Simplex Power-Web resistors, which have been designed specifically for use in load bank systems. The load elements are supported by high-temperature, ceramic-clad, stainless steel rods across their entire length, virtually eliminating element-to-element short circuits. The elements are arrayed in discrete, independently serviceable trays.

Groups of resistors comprise discrete Load Steps of various values. These steps are applied to the load bus via PLC-controlled contactors and overcurrent protection is provided by Load Fuses.

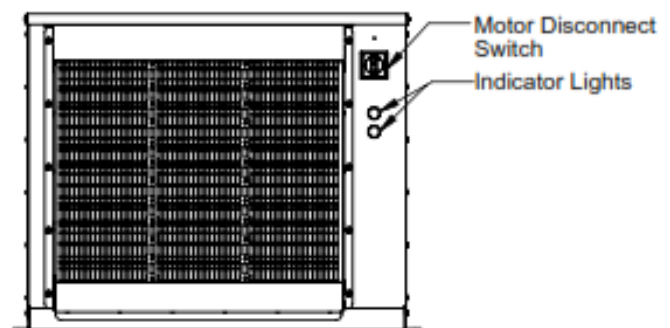

End view of a Polaris, showing air intake screen, Motor Disconnect Switch, and Indicator Lights.

I-D. SAFETY

The Polaris load bank is protected by various sensors (temperature switches, pressure switches, etc.) to ensure that the load bank is sufficiently cooled and that the exhaust does not exceed a safe temperature, which could damage the load bank or present safety hazards to personnel. Any unsafe condition detected by the Control System and its sensors will result in a drop of all load electrically disconnecting the load bank elements from the test source. For more details on safety monitoring points, refer to Section II-J, Alarms and Warnings.

I-E. UNPACKING

The following items are included with a newly shipped load bank. If any of the following are not included, please contact Simplex at 800-637-8603.

1. Controller (remote or local)
2. Operations manual
3. Drawing package

In addition, depending on the unit's specifications, certain optional equipment may be included:

1. Additional controllers
2. Current transformers
3. Other optional equipment. see drawing package for details on specific unit.

I-F. PRIMARY INSPECTION

Before installing a new unit, inspect the shipping crate and load bank. Physical or electrical problems could arise from handling and vibration. The following six-point inspection is recommended before installation and as part of a six-month maintenance schedule, or after any load bank relocation. Never apply power to a load bank before performing this procedure.

1. If the crate shows any signs of damage, examine the load bank in the corresponding areas for signs of initial problems.
2. Check the entire outside of the cabinet for any visual damage, which could cause internal electrical or mechanical problems due to reduced clearance. Inspect and operate Motor Disconnect Switch.
3. Open the control panel by removing the load bank's side (see drawings for details) and inspect all relays and control modules. Make sure all components are secure in their bases and safety bails are in place. Spot-check electrical connections for tightness. If any loose connections are found, inspect and tighten all remaining connections. Refer to Appendix E for torque specifications
4. Examine all accessible internal electrical components such as fuses, contactors, transformers. Spot check the tightness/torque of lugged wires at these components. If any loose connections are found, inspect and tighten all remaining connections. Refer to Appendix E for torque specifications.
5. Check cooling system by inspecting the fan motor and blade. Check fan blades for stress fractures. Slowly rotate blade by hand and note clearance of the blade tip through its rotation near the housing. Observe free rotation of the motor shaft.
6. Check the load element chamber for foreign objects, broken ceramic insulators, and mechanical damage.

If any problems are observed during the primary inspection, call Simplex at 800-637-8603, 24 hours a day.

I-G-1. INSTALLATION - PLACEMENT

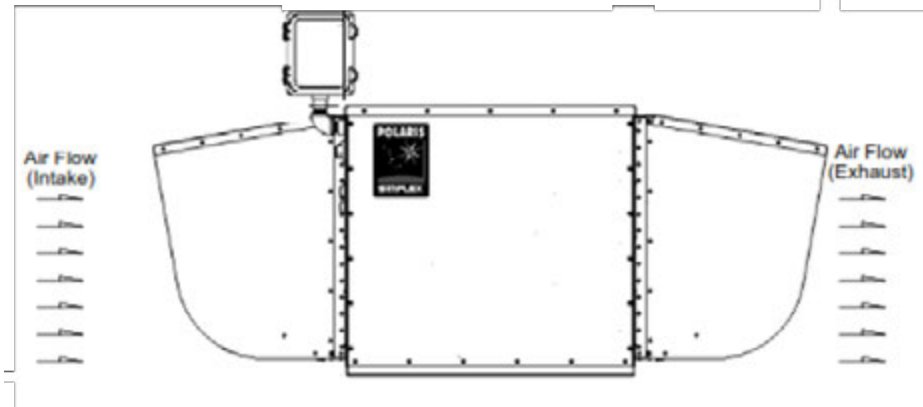

Type 3R load banks are intended for outdoor installation. Type 1 load banks must be installed indoors. The load elements in a Polaris load bank are cooled by a forced air system which discharges through the top of the cabinet. The load bank will produce a large quantity of heated exhaust air.

Placement of the load bank is one of the most critical

factors for safe operation of the load bank and should be overseen by trained personnel. The load bank must be installed and positioned according to its large airflow requirements.

- The load bank requires a minimum of 7.5 feet of clearance around the front and rear, and 3 feet of clearance on the sides. See clearance diagrams, next page.
- Never install any structure or object at any height above a load bank.
- Load banks installed indoors must be equipped with an exhaust air duct of minimum back pressure (supplied by others) which routes all load bank hot exhaust air outdoors.
- The load bank should be in a secure area accessible only by trained personnel.
- Never operate the load bank in a confined space without regard for adequate intake of air and provision for egress of high temperature exhaust.
- Consider that the load bank and any nearby equipment may have to compete for cooling air.
- Never allow hot exhaust air to be channeled by nearby objects in such a way that it recirculates through the cooling system.
- Load banks can exhaust air as hot as 650°F. Never operate the unit in the proximity of a fire suppression sprinkler system.



Damage to the load bank due to improper installation is not covered by the Simplex Warranty.



Improper installation of the load bank may result in damage to or destruction of the load bank, adjacent equipment, and the facility housing the unit.

I-G-1. INSTALLATION - PLACEMENT CONT'D

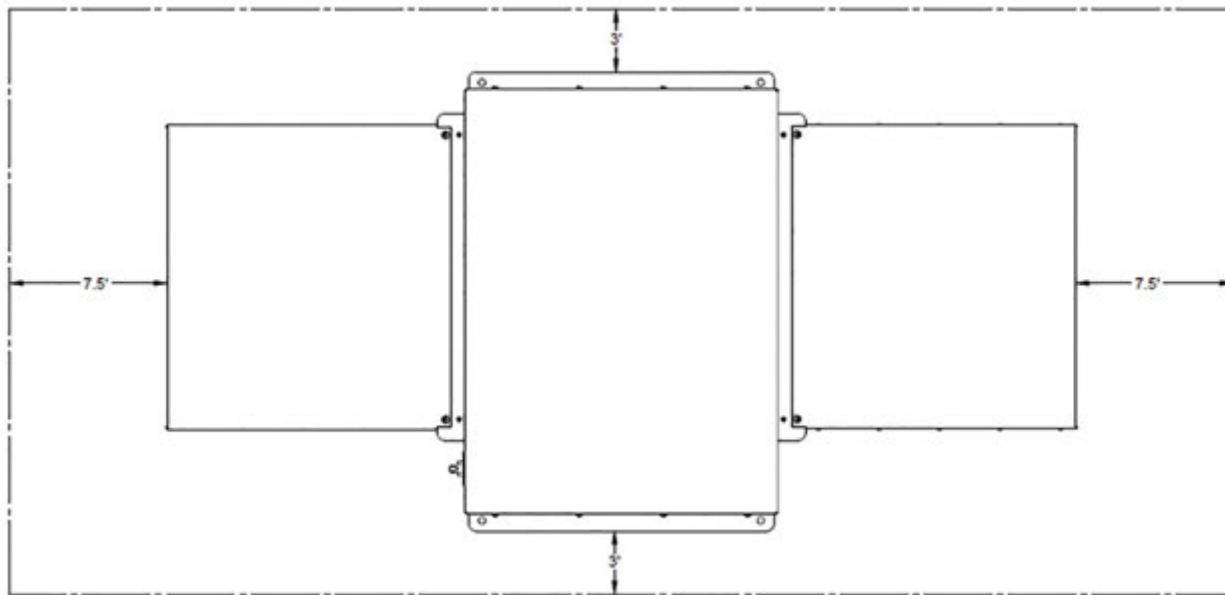

Top view of a Polaris, showing clearance requirements.

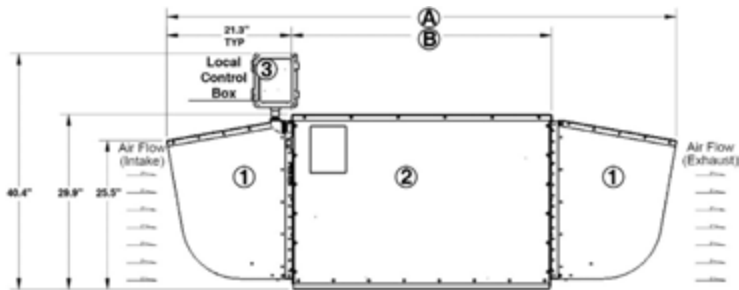

Side View

Polaris load banks are manufactured in three frame sizes, depending on the specified capacity.

Small - 27.5 kW

Medium - 50 kW

Large - 75 - 150 kW

Consult unit's drawing package for details on capacity and size.

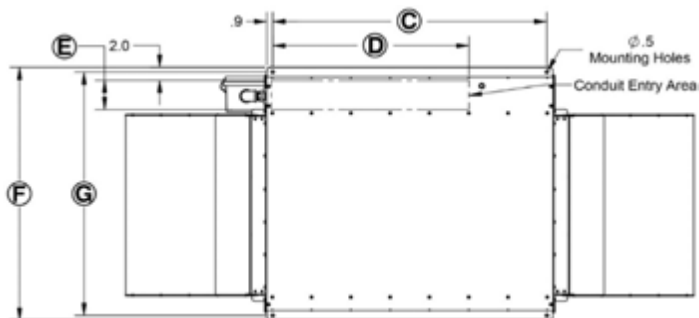

Bottom View

Dimension	Small	Medium	Large
A	64.9"	74.9"	86.9"
B	22.3"	32.3"	44.3"
C	19.9"	29.9"	41.9"
D	11.0"	19.0"	30.0"
E	4.5"	4.0"	4.5"
F	32.8"	38.8"	38.8"
G	31.3"	37.3"	37.3"

I-G-2. INSTALLATION - PROCEDURE

- Unless specified on the drawing, make all connections in compliance with the National Electrical Code (NEC) and all local codes or ordinances.
- Ground the load bank by connecting the grounding block to an earth ground or grounding rod.
- To route and connect the power source cables to the unit, remove the plate in the bottom of the control compartment (see diagram above). Cut holes in the best location, properly install the conduit, route appropriately sized cables and reinstall the bottom plate.
- Connect the source’s power output to the load bank via the Main Load Block.
- Wire the remote contacts for Load Dump, Load Ramp Down and Auto Trigger (if applicable) as described below and as shown in the unit’s drawing package.
- If applicable, install the Remote HMI as described below.
- If applicable, wire the sensor contacts for Backpressure Monitoring as shown in the unit’s drawing package.

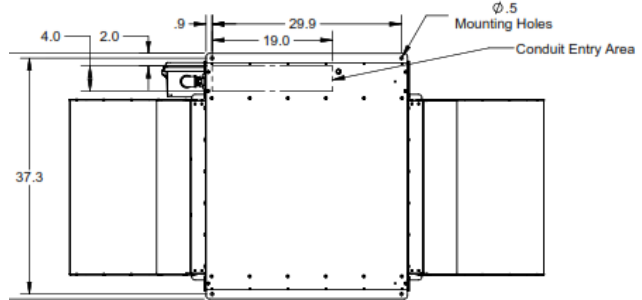

Bottom view of a Polaris, showing removable plate for cable connections.

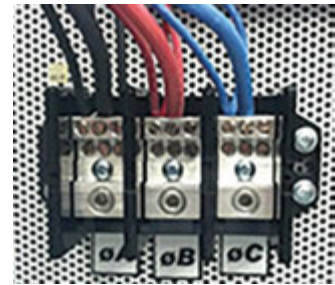

Installation - Remote HMI

If the HMI is installed directly on the load bank, and there is no remote controller, skip to the next section.

- Using holes and slots provided, mount the remote box where desired.
- Open the remote box to find the terminal block TB-H.
- Connect DC power as shown in the unit’s drawing package.
- Connect Communication wiring as shown in the unit’s drawing package, using Belkin 9841 or equivalent

Main Load Block (top) and Ground Block

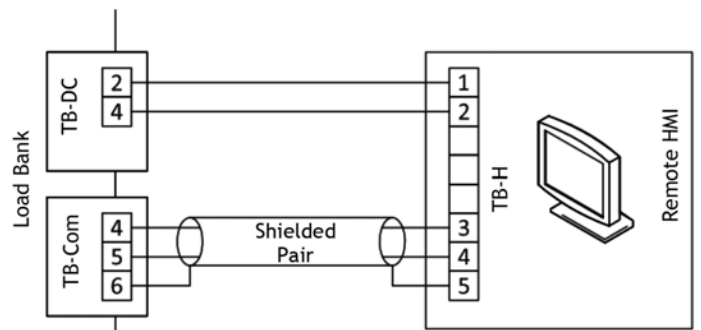

Example Remote HMI connection

I-G-3. INSTALLATION - INPUT SIGNALS

Load Dump: If the Load Dump feature is desired, remove the factory-installed jumper at TB-R 1-2 and connect customer-supplied Load Dump contacts to TB-R 1-2 (see drawing package). To dump the load, open the customer-supplied contact. To enable the load, close the contact.

Load Ramp Down: If the Load Ramp Down feature is desired, connect customer-supplied Load Ramp Down contacts per drawing package. To trigger a Load Ramp Down, close the customer-supplied contact. To resume normal operation, open the contact.

Auto Trigger: For the Auto Exercise, Fixed Load, and Auto Sequencing features, a customer-supplied external contact is necessary to start operation in these modes. See unit's drawing package for connection details. To trigger the selected Auto function, close the customer supplied contact. To stop the function, open the contact. See Section II-D, Load Control Modes, for more details.

Back Pressure Monitoring Sensors: Units equipped with the Back-Pressure Monitoring option use inputs from two customer-supplied pressure sensors. See unit's drawing package for connection details. For more details on Back Pressure Monitoring, see Section II-D-5-b.

I-G-4. INSTALLATION - CURRENT TRANSFORMERS

Load banks equipped with digital metering packages must have current transformers (CTs) installed. Units with only local metering are likely to arrive with CTs factory installed, but units equipped with the Auto Load Leveling feature will require onsite installation of system CTs either instead of or in addition to the local metering CTs.

- The CTs must be placed and oriented correctly to ensure that they accurately detect the current. The first CT must be installed on the phase A cable(s), the second on phase C.
- Orient the CTs so that the H1 on each ring is facing the power source.
- When the CTs are installed, connect them to the load bank per the drawing package.
- Each set of CTs must have its winding ratio entered in the unit's Settings under the User Settings section. See Section II-C, User Settings, for more details.
- If the system comprises multiple parallel generators, ensure that the CT placement will capture totalized power.

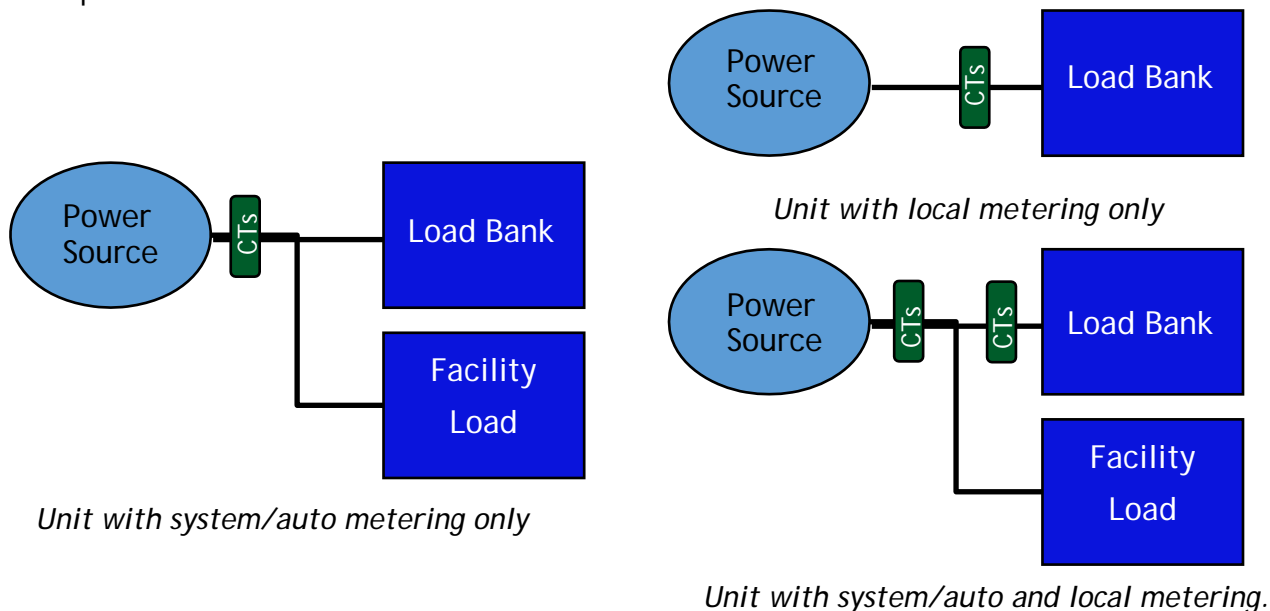

I-G-5. INSTALLATION - MODBUS COMMUNICATION

Simplex stationary load banks support monitoring/control by third party systems using the Modbus protocol, over either RS485 or TCP/IP communication, depending on which was specified for the unit.

To implement Modbus control and monitoring, connect the load bank to the control component per the unit's drawing package.

For more detail on Modbus control, see Section II-K, Modbus Controls.

I-G-6. INSTALLATION - ANTI-CONDENSATION HEATERS

Simplex load banks are equipped with space heaters, which require a dedicated power source independent of Control Power to prevent component damage from condensation and startup failure in cold environments.

Connect heater power per the unit's drawing package.

The heaters are thermostatically controlled and are set at the factory to come on below 50°F. When the load bank is installed, the thermostat should be set appropriately for the locale.



Heater Connection

I-G-7. INSTALLATION - BMS/BAS SIGNAL CONTACTS

The load bank provides a set of remote signal dry contacts that may be integrated into a facility's Building Management System or Building Automation System. The dry contacts provide basic information about load bank status. See the unit's drawing package for more details.

II. SIMPLEX LOAD MARSHAL™ CONTROL SYSTEM

II-A Navigation

From the Main Screen, the user may navigate to all the major sections of the controls program.

Common Features

The Main Screen introduces two features that are common to most other screens in the program.

- **Help/Information button:** The blue question mark button at the top right of the screen calls the appropriate section of the onscreen manual. Note that help screens are available only when there is no load applied.
- **System Status button:** This button to the left of the Help button calls the System Status screen, which displays all important system parameters.

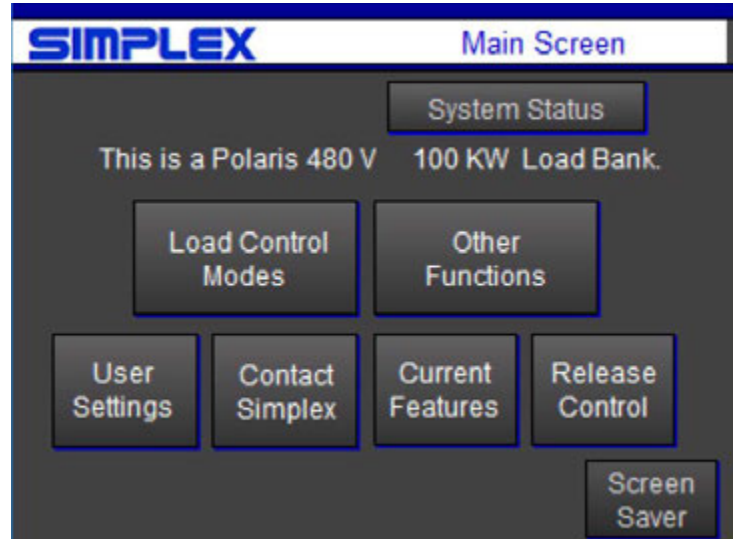

Navigation and Control Buttons

Load Control Modes: Calls the Control Mode Selection screen, where user selects the load bank's mode of operation. See Section II-D, Load Control Modes, for more details.

Other Functions: Calls the Options screen, where user selects other functions such as Step Quarantine, Self-Diagnosis, and various optional features. See Section II-F, Options Screen, for more details.

User Settings: Calls the User Settings screens, where all user-definable setpoints and parameters are entered. All setpoints should be entered before the load bank is operated. The User Settings screens are password protected. When this button is touched, the User Password must be entered before the User Settings screens will be called. See Section II-C, User Settings, for more details.

The default User Password is **4831600**.

For units equipped with a 6" HMI, this may be changed to a user-defined password.

See Section II-F, Options Screen, for more details.

Contact Simplex: Calls a Simplex contact list and important load bank information.

Current Features: Calls a list of all the load bank's options and capabilities.

Take/Release Control: Allows the load bank to be controlled from an alternate control platform, be it a 2nd Simplex HMI or a customer-supplied PC communicating via Modbus. See Section II-K, Modbus Controls, for more details.

Screen Saver: Blanks the control screen.

II-B. Specific Unit's Capabilities

The following section contains information on all functions and capabilities available on Simplex stationary load banks. **Not all load banks will be equipped with these functions.** For a list of your load bank's specific capabilities, select the Current Features screen accessible from the Main Screen - see Section II-A, Navigation, for more details. Contact Simplex for more information on available features and the possibility of adding functionality to a load bank.

II-C. User Settings

Before the load bank can be operated properly, the user-defined system settings must be entered.

Access the settings screens from the Main Screen using the User Settings button. A password is required to call the User Settings screens.

The default User Password is **4831600**.

For units equipped with a 6" HMI, a user-defined password is also available.

See Section II-F, Options Screen, for more details.

II-C-1. General Settings

The General Settings screen contains entries that define the power source and load bank system.

No. of Sources: Units that are equipped with Auto Load Leveling and that have been specified to do so are capable of paralleling with up to 3 sources. See Section II-D-5, Auto Load Leveling, for more details.

Select the number of sources and for each, enter its kW capacity.

System Voltage: Enter the system's rated voltage. The load bank PLC will compare this with the load bank's designed voltage to calculate derated capacities. A non-zero number must be entered before the load bank may be operated.

Ramp Down Step: A Load Ramp Down may be triggered during Auto operations by a user-supplied input signal (See Input Signals section for more

details) and will also occur upon termination of automatic mode operations. The Ramp Down steps load down to zero at a set interval. The Ramp Down Step defines the amount of load to be dropped with each step.

Meter CT Ratios: For units equipped with electrical metering packages, a current transformer (CT) ratio must be provided for each set of CTs. For Simplex-provided CTs, the ratio will have been entered at the factory.

Default Settings: Resets all User Settings to factory recommended default values.

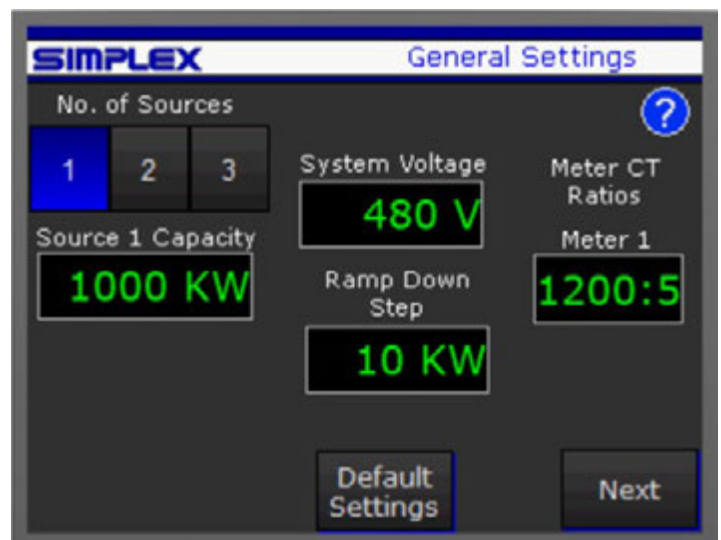

II-C-2. Auto Load Leveling Settings

Connected in parallel with another load, a load bank equipped with Auto Load Leveling will act to maintain the total system load within a user-specified “Window,” or power level range. If the system power level is above or below the window, the load bank will add or remove load in steps toward the window. The steps occur at user-defined intervals. All settings defining the Auto Load Leveling function are entered on the Auto Settings screen.

Window Low % and High %: These entries define the desired window, or range, of operation. Note that the setpoints are entered as % of total source capacity.

Emergency High %: Should the system power level reach this setpoint, the load bank will instantly drop a block of load calculated to return the power level to within the defined window.

Emergency Low %: This setpoint only comes into play on units equipped with Regenerative Power Protection (Regen). When the Emergency Low setpoint is reached, the load bank will instantly apply a block of load calculated to return the power level to within the defined window. See Section II-D-5-c, Reverse Power Prevention Operation, for details.

Auto Start Delay: Defines the amount of time after the load bank starts up before the Automatic functions begin to regulate the load bank load.

Step Delays: Defines the amount of time between each step up or down as the load bank regulates its load.

Example Settings – Auto Load Leveling Window shown in green:

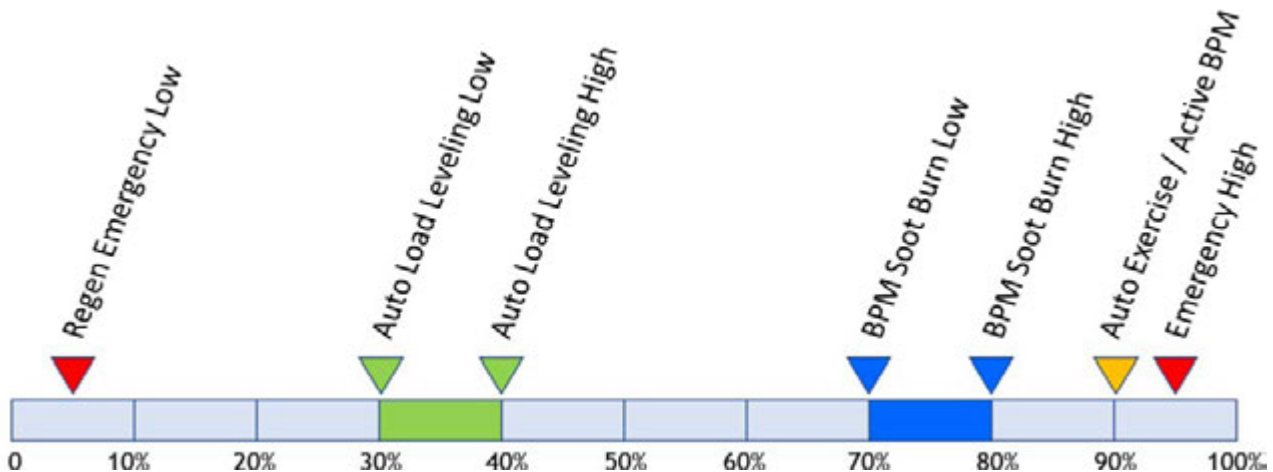
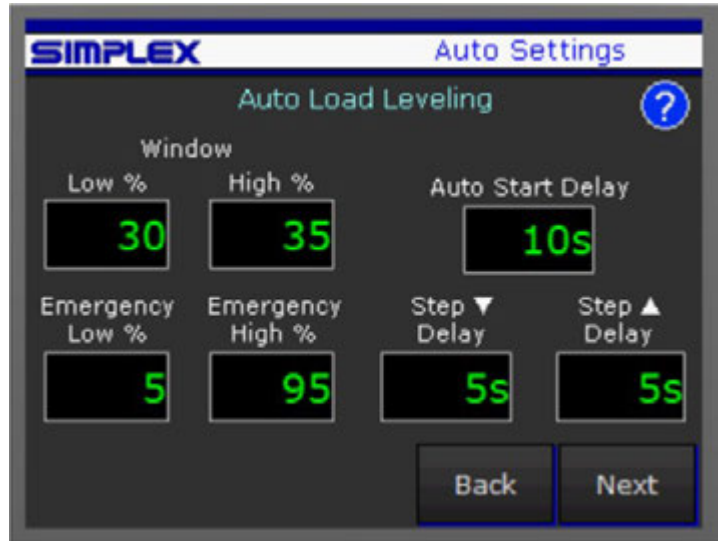

II-C-3. Backpressure Monitoring (BPM) Settings

Monitoring two user-supplied pressure sensors located in a generator’s exhaust stack, a load bank equipped with Auto Load Leveling and the BPM option will react to high pressure conditions by increasing the load to within a user-defined elevated “Soot Burn Window” of operation.

Soot Burn Window Low % and High %: These entries define the desired window of operation when attempting to clear a backpressure condition by raising exhaust temperature. Note that the setpoints are entered as % of total source capacity.

Active BPM Check Target: Upon startup or after clearing a fault/alarm, a load bank with the BPM option enabled will step up to a BPM Check power level, actively checking for a high-pressure condition. Note that this setpoint is entered as a % of total source capacity. Also, the BPM Check

power level is the same as the Auto Exercise/Fixed Load power level.

Emergency Low %: This setpoint only comes into play on units equipped with Regenerative Power Protection (Regen). When the Emergency Low setpoint is reached, the load bank will instantly apply a block of load calculated to return the power level to within the defined window. See Section II-D-5-c, Regenerative Power Protection Operation, for details on Regen operation.

Soot Burn Duration Minutes: When a high backpressure condition is triggered, the load bank will step up into the Soot Burn Window of operation. After the condition clears, it will remain in that elevated window for this user-defined period before returning to the normal Load Leveling window of operation.

Alarm Shutdown Delay Minutes: If the BPM Alarm signal is triggered and does not clear after this user-defined amount of time, the load bank will step down to zero load and disable all auto functions until the alarm is reset, if a problem other than soot buildup exists.

Example Settings – Soot Burn Window shown in blue:

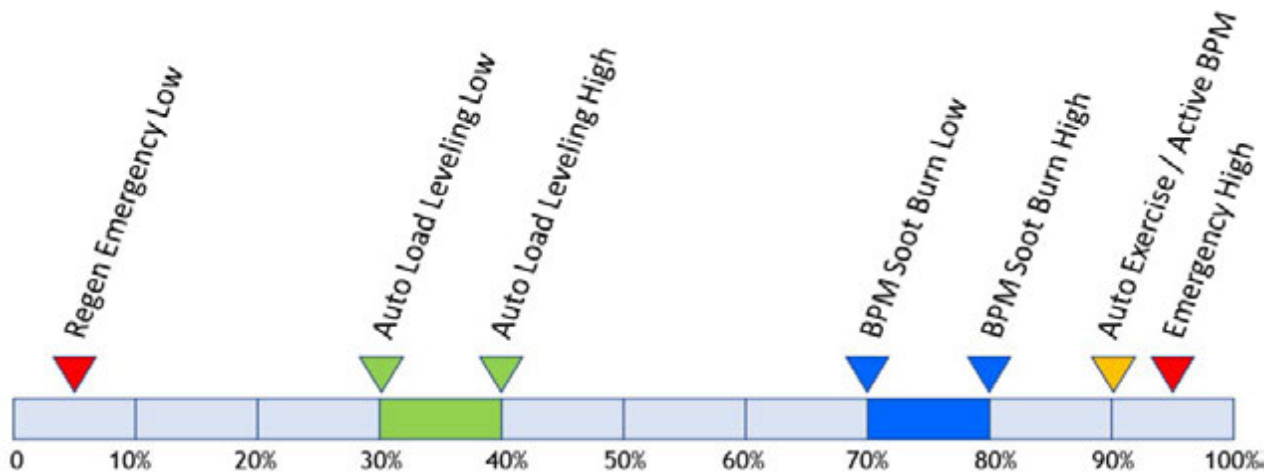
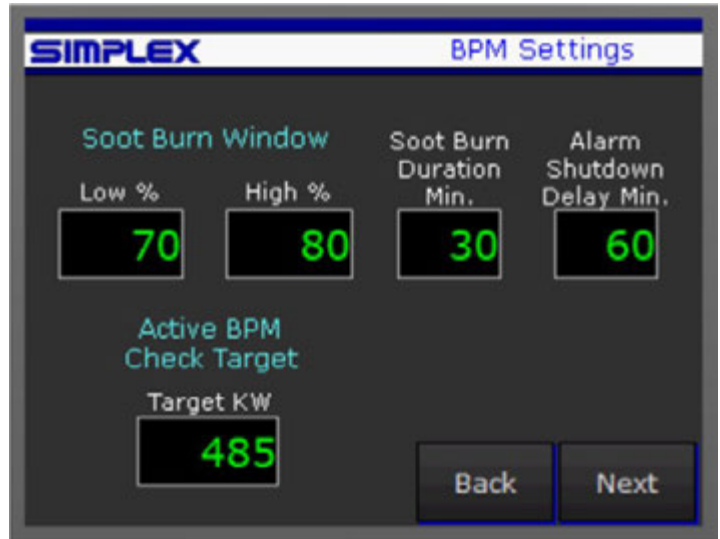

II-C-4. Miscellaneous Settings

Auto Exercise/Fixed Load Target %: When an Auto Trigger input is received, and the load bank is equipped with Auto Exercise or Fixed Load capabilities, the load bank will automatically apply this amount of load until the trigger is removed. See Section II-D-7/8 for more details.

Also note that a for a load bank equipped with the BPM option, this value serves as the target for the Active BPM Check. See Section II-D-5-b, Backpressure Monitoring Operation, for more details.

Step Delay: The rate at which the load bank will step up/down while in Auto Exercise operation or in Active BPM Check operation. If the load bank is equipped with the Auto Load Leveling function, this level will be entered on the Auto Load screen, as the Auto Level Step Up Delay.

Fahrenheit/Celsius Selection: For a load bank equipped with thermocouples, the temperature readings may be set to display in either system.

Load Dump Bypass: The user-installed Load Dump switch or contact may be bypassed, removing the necessity of having an input present to operate the load bank.

Single Phase Operation: Load Banks designed as three phase units may be operated at a derated capacity in single phase mode. The load bank must be connected and configured in a specific way. See Appendix D, Single Phase Configuration, for more details. Selecting Single Phase operation with this button will cause the load to apply appropriate derate calculations to the value of each of its load steps.

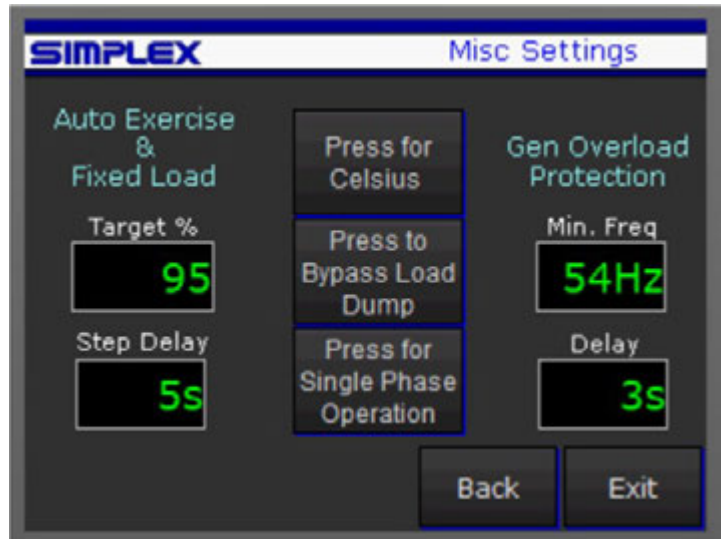

Genset Overload Protection

The load bank can be configured to detect severe overloading of a genset or source. If such a condition is detected, the load bank will step down to zero load and reset all automatic functions.

Minimum Frequency: The setpoint at or under which the load bank will detect that the genset's output is drooping to a point of concern.

Delay: The amount of time a genset will spend at or below the Minimum Frequency mentioned above before the load bank begins to step down to zero load.

II-D. Load Control Modes

This screen displays the various control modes with which the load bank is equipped, and which may be selected.

Manual Load: In this mode, the load bank's load steps may be individually toggled, and groups of steps may be toggled using the Master Load switch. See Section II-D-2, Manual Load, for more details.

Numeric Load: In this mode, the user enters a desired amount of load to be applied and may toggle that load with the Apply Load button. The applied load may be adjusted up or down by a user-defined amount using the Load Jog function. See Section II-D-3, Numeric Load, for more details.

Sequence Load: In this mode, the load bank can be set up to automatically cycle through a sequence of user-defined "Stages," with each Stage applying a

user-defined amount of load for a user-defined time. The sequences may be set to apply load in blocks or in step increment/decrements. A sequence may be triggered from the control screen or may be set to run automatically on a user-supplied Auto Trigger input. See Section II-D-10, Sequence Loading, for more details.

Auto Load Leveling: In this mode, the load bank operates in parallel with another load to maintain the system total power level within a user-defined "window" of operation. See Section II-D-5, Auto Load Leveling for more details. There are two optional functions that expand the capability of the Auto Load Leveling function:

- **Regen (Regenerative Power Prevention):** With this option enabled, a load bank equipped with Auto Load Leveling will react to a user-defined "Emergency Low" setpoint to prevent a reverse power condition. See Section II-D-5-c, Regenerative Power Prevention Operation, for more details.
- **Backpressure Monitoring:** With this option enabled, a load bank equipped with Auto Load Leveling accepts input signals from user-supplied pressure sensors and works to automatically clear any backpressure conditions by raising the power level to burn soot out of a generator's exhaust stack. See Section II-D-5-b, Backpressure Monitoring Operation, for more details.

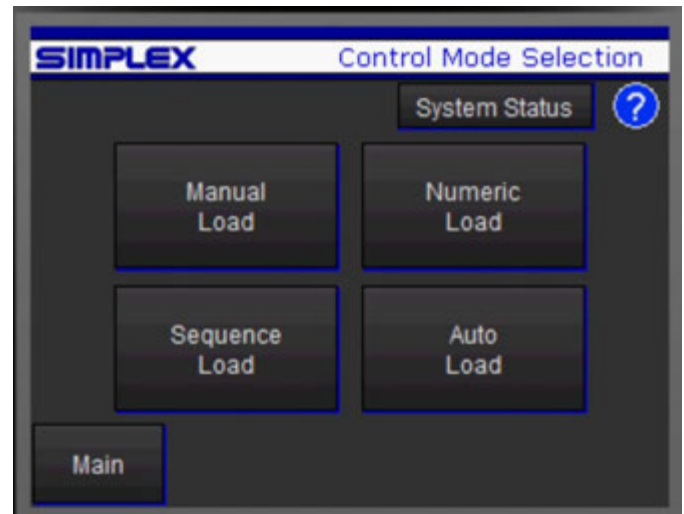

II-D-1. Control Screens

Common Features

These Manual Control Screen examples illustrate some features common to all control screens.

- **Low Battery Indicator:** The battery symbol will appear in the upper right corner when the PLCs memory backup battery is due for replacement. The PLCs use CR2354 or equivalent batteries.
- **System Status Indication:** In a field to the right of the control power button, various system status messages will be displayed. In the example to the left, "Ready to Load." visible. Other messages will appear here to indicate various load bank conditions:
- **Starting Up:** After control power is energized, there is a five second time delay before load may be applied, allowing system and fault checks prior to loading.
- **Ready to Load:** Indicates that the system has completed the startup process, that there are no alarm conditions present, and that the system is ready to apply load.
- **Check System:** Indicates that an alarm or other condition is present, and that load may not be applied. Navigate to the System Status screen for more information.
- **Load Dump Active:** Indicates that the user-supplied remote Load Dump contact is open and not bypassed. See Load Dump button section on next page for more details.
- **Ramp Down Active:** Indicates that the user-supplied Ramp Down contact is closed, triggering a step down to zero load.
- **Cooldown Mode:** For two minutes after any load has been applied, load banks with cooling fans will maintain the fan operation to allow complete cooldown of the resistive elements. If Control Power is turned off before this two minutes elapses, the fan will remain running for the remainder of the time. This Cooldown Mode may be canceled with a button that appears at the bottom of the screen. Our recommendation is that the cooldown period be allowed to run its course.
- **Specific Alarm/Warning Indications:** See Section II-J, Alarms and Warnings, for details on other messages displayed in this field.



II-D-1. Control Screens cont'd

- **Auto Shutdown:** If a load bank in Manual Load or Numeric Load operation has had no load applied for one hour, it will shut itself down. For the last 30 minutes of that hour, the countdown will appear at the bottom center of the screen. In any Automatic mode, the load bank will shut itself down after 2 minutes of no call for load. See Section II-D-4 through II-D-9 for more details.
- **Load Dump:** In the lower right corner of each control screen is the local Load Dump button. Toggling the Load Dump will drop all applied load. The button must be reset before load may be reapplied.
- **Metering Band:** For load banks equipped with metering, the electrical values are displayed on every control screen. On units equipped with a 6" or larger touchscreen, touching the Metering Band will call the Data View/Logging screen. See Section II-E, Data Logging, for more detail.
- **Alarm Banner:** Any system alarm will cause an Alarm indication to display in the upper banner of every screen. Certain alarms and conditions will display beneath the banner, to the right of the Control Power button. Press the System Status button for more details on any alarm.
- **Alarm Reset:** All alarms latch and must be reset after the condition has cleared. Note that latched alarms will persist even through a Control Power shutdown, so cycling control power will not clear a latched alarm. The Alarm Reset button will appear on the screen's lower right in the place of the Load Dump button.
See Section II-J, Alarms and Warnings, for more details on specific alarms.
- **Back Button:** Navigates back to the Load Control Modes screen. Navigation button is available only when the Control Power is turned off.

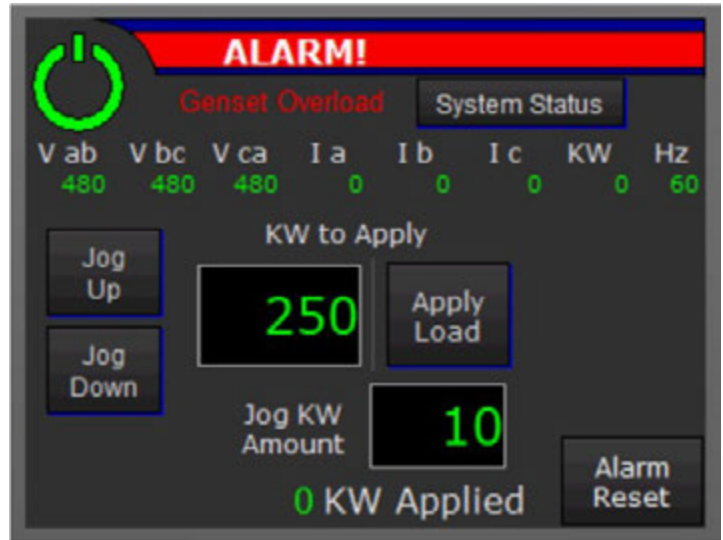

II-D-2. Manual Control

Master Load Button: The Master Load button toggles to allow individual step buttons to engage their steps.

Step Toggle Buttons: Each load step toggle button displays the step number and the kW value of the step, with voltage and phase derating considered. When the step button is toggled on, there will be a blue border around the perimeter of the button, and when the PLC is commanding the step relay to energize, the upper half of the button will turn blue. See Step 7 in the example screen to the right.

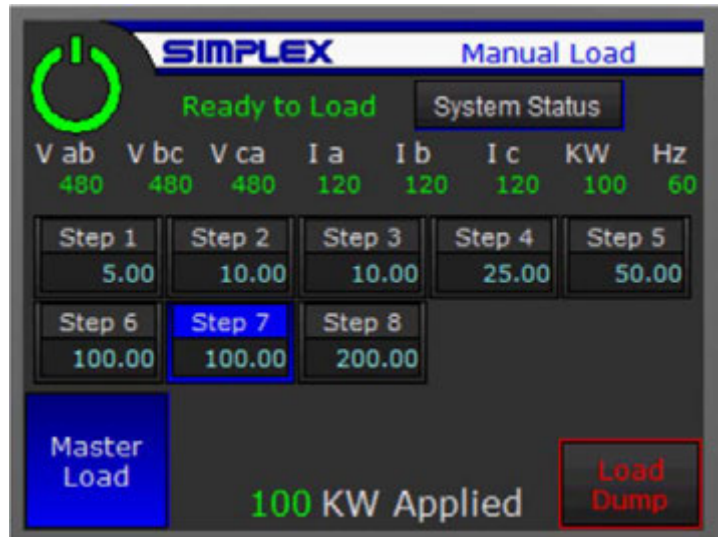

II-D-3. Numeric Load

KW to Apply Entry: Enter the desired KW.

Apply/Remove Load Button: Toggle this button to apply or remove the entered load.

Jog KW Amount Entry: Enter the amount by which to adjust the load up or down with the Jog buttons.

Jog Up/Jog Down Buttons: These momentary buttons will adjust the KW to Apply up or down by the Jog KW Amount.

Steps On: Indicators denote which discrete load steps are currently energized.

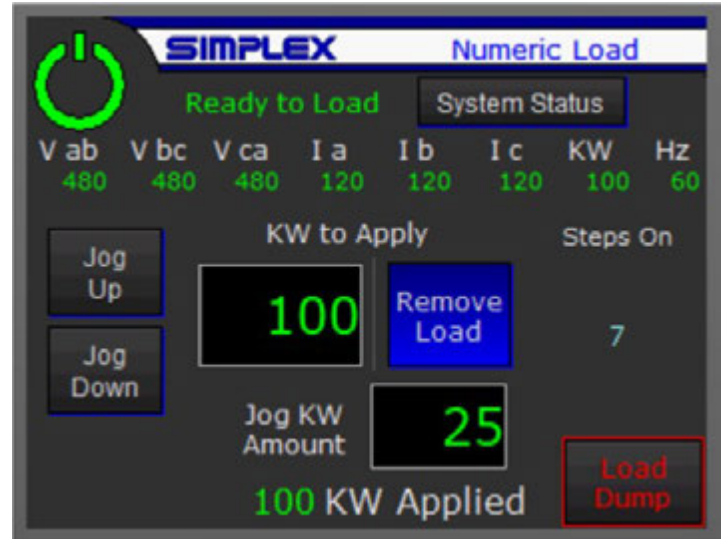

II-D-4. Automatic Load Modes

A load bank with the Load Marshal control system may be equipped with one or more of several available modes of automated operation.

- **Auto Load Leveling:** When Auto Load Leveling is enabled, the load bank will react to changes in a parallel load to maintain the overall system load steady within a user-defined “window” of operation. When the load bank senses the need to apply load, it will turn itself on if necessary, and when there is no call for load from the load bank, it will turn itself off. Auto Load Leveling operation may be enhanced by two optional supplemental functions.
 - ◆ **Regen (Reverse Power Prevention):** When the Regen option is enabled with Auto Load Leveling, the load bank will act to prevent a reverse power condition by applying blocks of load if the power falls to an “Emergency Low” setpoint.
 - ◆ **BPM (Active Backpressure Monitoring):** When the BPM option is enabled with Auto Load Leveling, the load bank will act to correct excessive backpressure conditions in a generator’s exhaust stack by adding load to raise exhaust temperature.
- **Auto Exercise:** When Auto Exercise is enabled, and a user-supplied Auto Trigger signal is present, the load bank will turn itself on, step up to a user-defined power level at a user-defined rate, and maintain that power level until the Auto Trigger is removed, at which point it will step down to zero load at the same rate, and then turn itself off.
- **Fixed Load:** When Fixed Load is enabled, and a user-supplied Auto Trigger signal is present, the load bank will turn itself on, apply a user-defined amount of load in one block load, and maintain that load level until the Auto Trigger is removed, at which point it will drop to zero load in one block drop, and then turn itself off.
- **Auto Sequencing:** When Auto Sequencing is enabled, and a user-supplied Auto Trigger signal is present, the load bank will turn itself on and execute a user-programmed load sequence (see Section II-D-10, Sequence Loading, for more details), then turn itself off.

Note that on initial startup, except in the case of the Regen option, all Automatic Load Modes will begin to operate after a user-defined Auto Start Delay (see Section II-C, User Settings).

II-D-4. Automatic Load Modes cont'd

Auto Mode Selection: Enable/Disable toggle buttons for each available auto mode appear on the Auto Load screen. Note that enabling any mode locks out all others. Also note that having any mode enabled will lock out navigation back to the Mode Selection screen.



The Load Leveling function applies load seeking a user-defined level using the metered kW value as feedback.

If no metered kW is seen, the PLC will continue adding load and may overload the power source. Always ensure the meter is operating properly before enabling Auto Load Leveling!

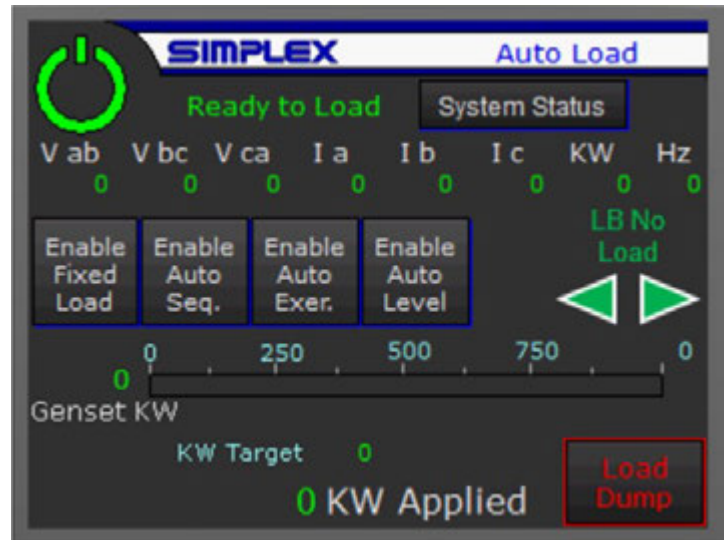

II-D-5. Auto Load Leveling

Enable/Disable Auto Level: Toggles the Auto Load Level function. If the function is enabled and there is a call for load, meaning that the load bank needs to apply load to keep the system load level within the user-defined window of operation, the load bank will turn on its own control power and begin to regulate the load.

When there is no call for load (i.e. the parallel load is within or above the window of operation with no load bank load applied), the load bank will turn off its own control power after a two-minute delay.

Regen/BPM Indicators: Indicate whether these optional functions are enabled.

Load Bank Activity Indicator: Indicates the status of the load bank as it attempts to maintain system load within the window of operation. Displays the following conditions:

- Stepping Up (Adding load)
- Stepping Down (Removing load)
- In Window
- Emergency Up (Regen Operation)
- Emergency Down
- Load Bank No Load
- Load Bank Full Load

Genset KW: Displays the total system power. To the left is a numeric display and to the right is a bar graph showing the current power level as a percentage of the system total capacity. A red line demarcates window high level setpoint.

KW Target: Displays the Min/Max setpoints of the target window of operations.

KW Applied: Displays the amount of load currently applied by the load bank.

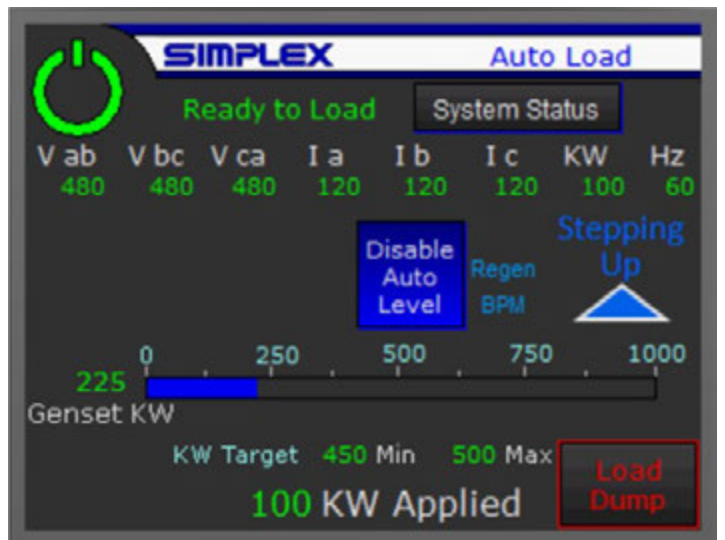

II-D-5. Auto Load Leveling cont'd

II-D-5-a. Auto Load Leveling Operation

When Auto Load Leveling is enabled, the load bank will monitor total system kW to determine its actions. If system kW is below the user-defined window of operations, the load bank will add load, and if the system kW is above the window, the load bank will drop load to maintain total power within that window.

In normal Load Leveling operation, the load bank will add or drop an amount of load equal to the load bank's smallest load step (the load bank resolution) at intervals defined by the user. See Section II-C-2, Auto Load Leveling Settings, for more details on the Auto Load Leveling time delays.

If the total system kW is greater than the Emergency High setpoint, the load bank will instantly drop a block of load calculated to bring the system back to within the window of operation.

When Auto Load Leveling is enabled, if the load bank is "off," meaning that the control power is not active and the cooling fans (if applicable) are not running, the unit will turn its own control power on and start its cooling fans any time that the total system kW dips below the window of operations, and begin to add load.

When there is no call for load bank load (e.g. the total system kW is in the window of operations without any load bank load applied) for two minutes, the load bank will shut itself down until the call for load returns.

If Auto Load Leveling is disabled (i.e. turned off) during operation, the load bank will step down to zero load and shut itself down.

II-D-5-b. Backpressure Monitoring Option

Enabling Auto Load Leveling Options:

Available options are enabled/disabled on the Other Functions screen accessed from the Main screen

Backpressure User Inputs: The BPM option monitors input signals (BPM Warning and BPM Alarm) from two user-supplied pressure sensors in the genset's exhaust stack. See drawings for user inputs.

Soot Control Mode: When a high-pressure condition is indicated by either sensor, the load bank will step up to a higher user-defined window (Soot Burn Window) of operations to

increase the genset's exhaust temperature and burn accumulated soot out of the stack. After the condition has cleared, the load bank will maintain operation within the Soot Burn Window for a user-defined amount of time before returning to regular Auto Load Leveling operation.

BPM Alarm Shutdown: If the BPM Alarm signal does not clear after a user-defined amount of time, the load bank will step load down to zero, shut itself off, and disable all auto functions, under the assumption that a larger issue exists and must be dealt with before operations may continue.

Active Backpressure Check: Upon startup, the load bank will execute an Active Backpressure Check by stepping its load up to a user-defined point (ideally very high in the genset's range) in an active attempt to trigger a backpressure condition. If either the BPM Warning or Alarm are triggered, the load bank goes into Soot Burn Mode as described. If no backpressure condition is triggered, the load bank will switch to normal Auto Load Leveling operation and step down into that window of operations.

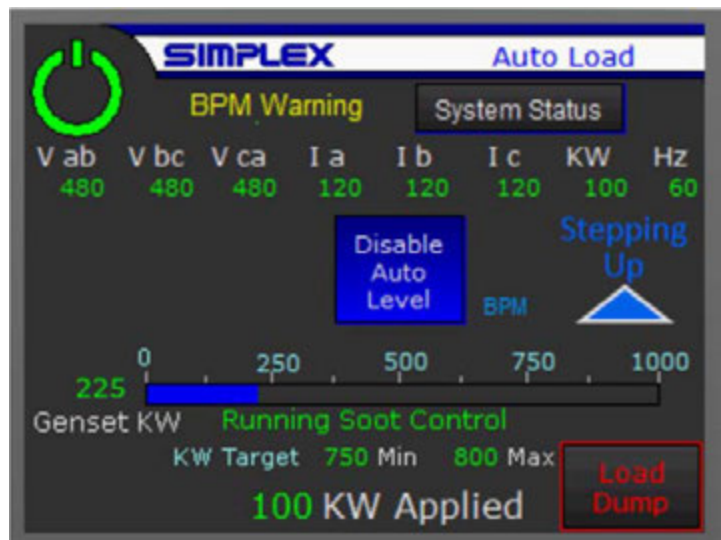

II-D-5. Auto Load Leveling cont'd

II-D-5-c. Regen (Reverse Power Prevention) Option

Emergency Low Setpoint: With the Regen option enabled, the load bank operates as with standard Auto Load Leveling with an added Emergency Low setpoint. When total system kW drops to the Emergency Low setpoint, the load bank will instantly add in one block an amount of load calculated to raise the load level to within the Auto Load Leveling window of operations, to prevent any reverse power conditions.

Emergency Low Setpoint Arming: Upon initial startup or after an alarm reset, the Emergency Low Setpoint is not armed, meaning that the load bank will not react to the setpoint, until the total system kW is above the Emergency Low setpoint.

Time Delay Bypass: With the Regen option enabled, the user-defined Auto Startup Delay as well as the system Startup Time Delay are bypassed, and the load bank will begin to respond to calls for load instantly.

II-D-6. Auto Trigger Input

The Auto Exercise, Fixed Load, and Auto Sequence functions all use a user-supplied Auto Trigger input. See drawings for user connections.

II-D-7. Auto Exercise

When Auto Exercise is enabled, and the Auto Trigger Input signal is present, the load bank will turn itself on and start its cooling fans if applicable. After the system Startup Delay and user-defined Auto Start Delay, it will step up to a user-defined level and remain there until either the Auto Trigger signal is removed, or Auto Exercise is disabled at the screen, at which point it will step down to zero load and turn itself off.

See Section II-C-4, Miscellaneous Settings, for details on entering Auto Exercise load level.

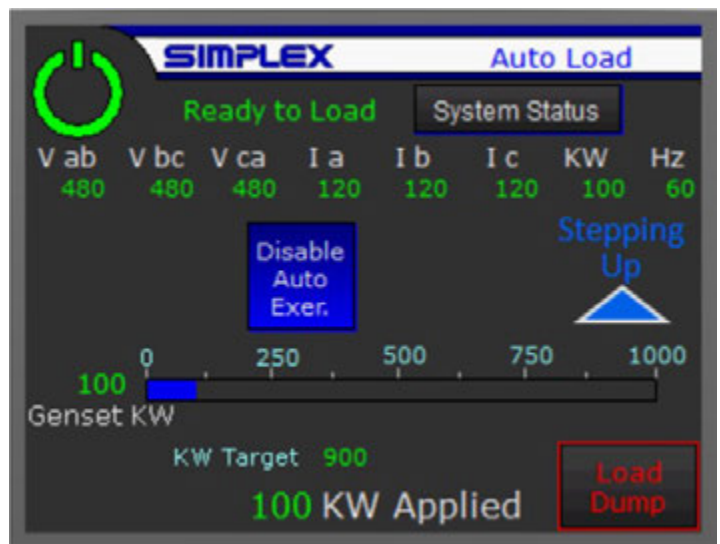

II-D-8. Fixed Load

When Fixed Load is enabled, and the Auto Trigger Input signal is present, the load bank will turn itself on and start its cooling fans if applicable. After the system Startup Delay and user-defined Auto Start Delay, it will apply in a single block a user-defined load and remain there until either the Auto Trigger signal is removed, or Fixed Load is disabled at the screen, at which point it will drop all load and turn itself off.

See Section II-C-4, Miscellaneous Settings, for details on entering Fixed Load level.

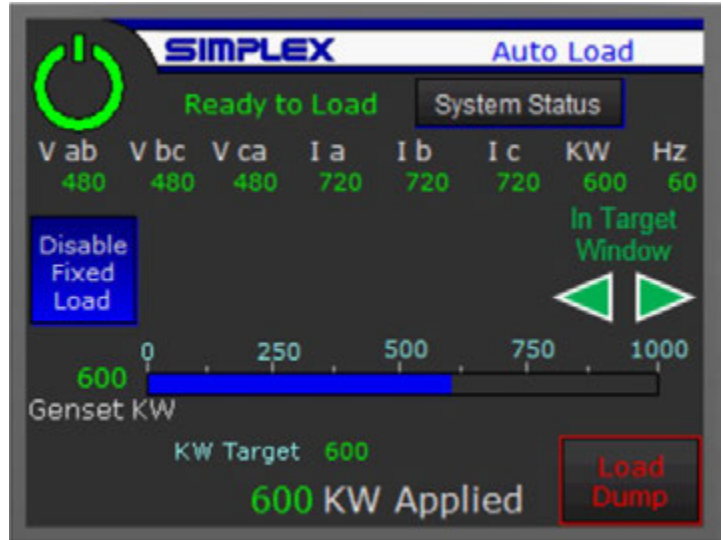

II-D-9. Auto Sequence Load

When Auto Sequence is enabled, and the Auto Trigger Input signal is present, the load bank will turn itself on and start its cooling fans if applicable. After the system Startup Delay and user

-defined Auto Start Delay, it will execute a previously programmed load sequence. When the sequence is completed, the Auto Trigger signal is removed, or Auto Sequencing is disabled at the screen, the load bank will drop all load and turn itself off.

See next section, Sequence Loading, for more details on programming and running load sequences.

Block/Step Sequence Indicator: under the

Genset kW bar graph, an indication will display when a load sequence is running and will denote whether the system is in Block or Step Sequence mode. See next section, Sequence Loading, for more details.

Sequence Screen Navigation: When an Auto Load Sequence is running, it is possible to navigate between the Auto Load screen and the Sequence Loading screens

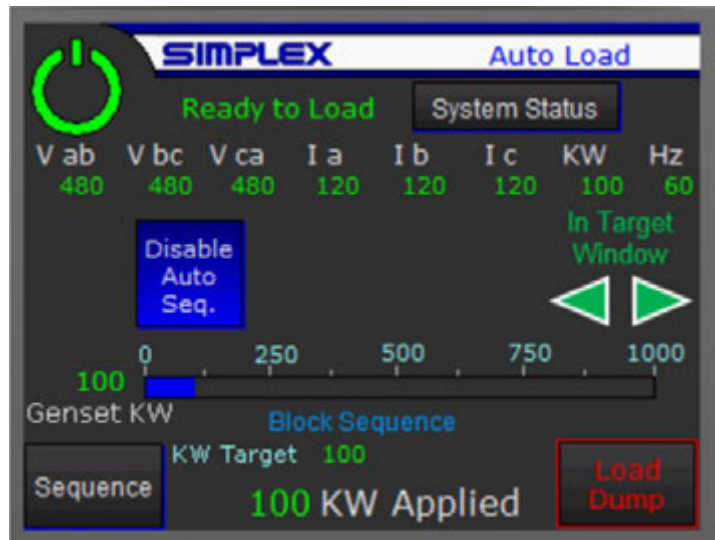

II-D-10. Sequence Loading

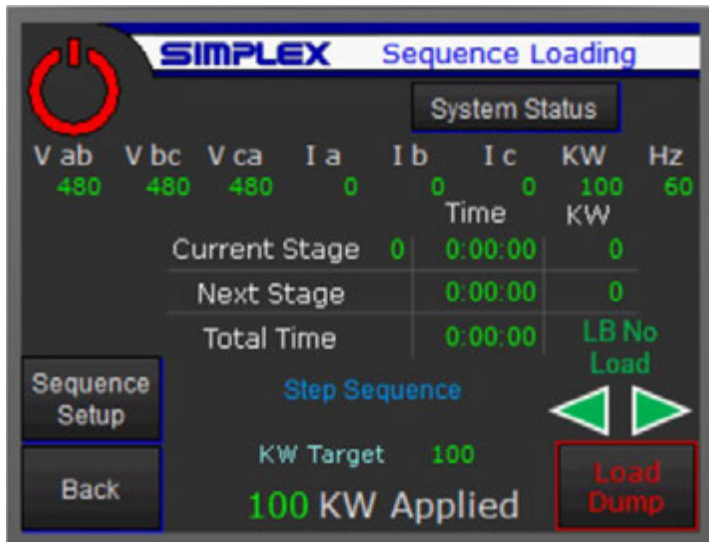

A load bank equipped with Sequence Loading may be programmed to run a sequence of user-defined “stages.” Each stage is defined with a load level and a duration. A load bank with a 4” screen may have up to 10 programmed stages, while one with a 6” or larger screen can accommodate up to 16 stages.

Current Stage: Displays the number of the stage currently being executed, along with the time remaining in that stage and the programmed kW.

Next Stage: Displays time and kW information for the next stage to be executed.

Total Time: Displays the total time remaining in the full sequence.

Sequence Setup: Navigates to the Sequence Setup screen. See next page for details.

Step/Block Sequence Indicator: Denotes which sequence mode for which the controls are currently set. See Sequence Setup section on next page for details on selecting Step or Block mode.

Block Sequence: The desired load for each programmed stage in the sequence will be applied in one block load for the specified amount of time, then the load bank will apply the next stage’s load in one block and so on.

Step Sequence: The load bank will step between stage loads. When the sequence starts, the load bank will step incrementally to the first stage’s load level and remain there for the specified amount of time. It will then step either up or down to the next stage’s level. Note that the timer for each step’s programmed duration does not begin until the level is reached.

Enable/Disable Repeat: The load bank may be set to repeat the entire programmed sequence. It will continue to cycle through the sequence until Repeat is disabled.

Start/Stop Sequence: This button toggles to run or stop the programmed sequence. Note that this button will appear in place of the Sequence Setup button when control power is energized.

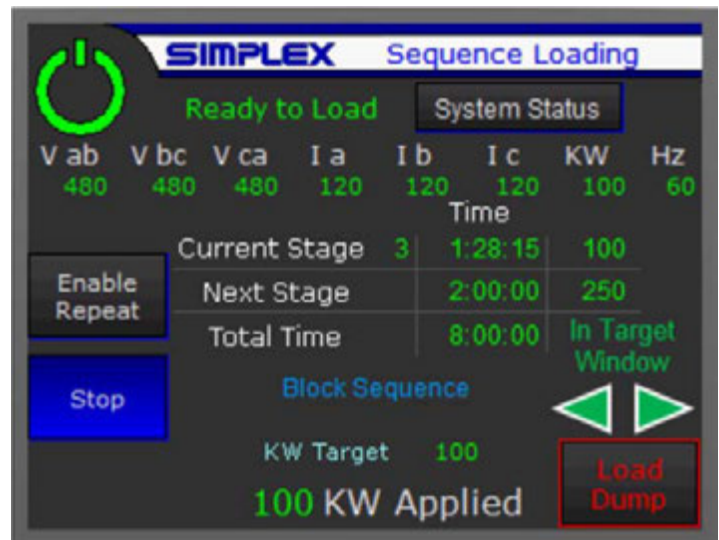

II-D-10. Sequence Loading cont'd

Sequence Setup

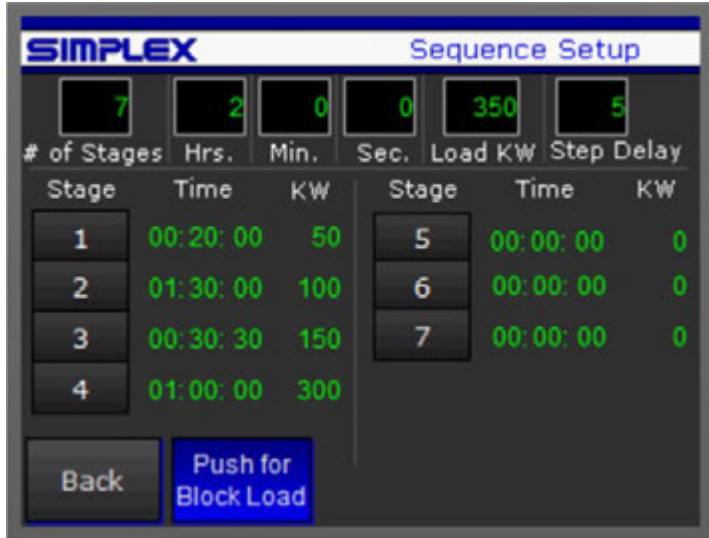

of Stages: Enter the desired number of Stages to include in the Sequence.

Stage Definition Entries (Hrs., Min., Sec., Load KW): Enter desired levels for each parameter.

Stage Buttons: Pushing a Stage Button will load the parameters currently in the Stage Definition Entry fields to that Stage's definition.

For example, in the definition on the right, pushing the Stage 5 button will load the values currently in the entry windows at the top of the screen into the Stage 5 definition. Stage 5 will then be defined as 350kW for 2:00:00.

Push for Block Load/Step Load: Select the sequence mode.

Step Delay: The Step Delay entry in the upper right corner only applies to, and will only appear when the sequence is set up for, Step Sequence

Loading. This defines the amount of time between increments as the system steps to the next Stage's defined power level.

II-E. Data Logging

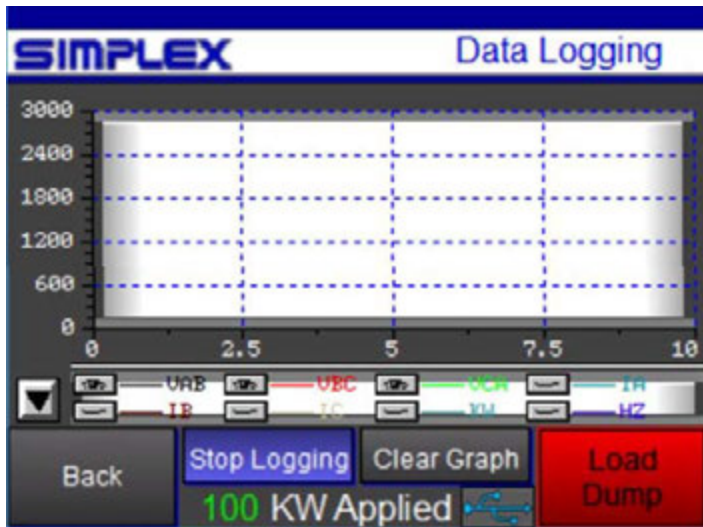

Data Logging is an option available on units equipped with 6" or larger control screens, accessed by touching the metering display bar on any load screen. Data is logged from the HMI onto a flash drive connected through an exterior USB port. A 1GB flash drive can store 250 million data points, according to the HMI manufacturer.

Show/Hide Visibility: (Up/Down Arrow button on the far left of the screen, above the Back Button) Toggles the visibility controls for parameter graphs.

Visibility Controls (open/closed eye icons): Toggle the visibility for each parameter's trace.

Start/Stop Logging: Toggles data logging to the flash drive. This button, along with the USB indicator to the right of the kW Applied display, will be visible only when a flash drive is present and

ready to begin logging.

Clear Graph: Resets the graph, erasing all plotted points. Does not affect data logged to the flash drive.

Logged Data: Data is logged on the flash drive as a .csv file, with each set of points time and date stamped. This file may be transferred to a laptop or other computer and opened in a spreadsheet with software such as Excel.

II-F. Options Screen

Enable/Disable Capacity Limit: The capacity limit feature allows the user to enter a maximum load available. Enable and enter desired limit, for example to prevent overloading a genset or another source.

Change User Password: Available only on units equipped with 6" or larger screens. Allows a user to set up a custom password to control access to settings screens.

Run Time Hours: Displays a running total of time the cooling fan has been running. See Section IV, Maintenance, for recommended maintenance intervals.

Enable/Disable Regen & BPM: For units equipped with Automatic Load Leveling and these optional features, Regen and BPM are enabled here. See Section II-D-5, Automatic Load Leveling, for more details.



II-G. Step Quarantine

A load step may be found to be deficient or in need of maintenance. Blown fuses, for example, are a common cause of load steps delivering less than rated power. Until repairs can be affected, a deficient step may be taken out of operation via the Step Quarantine function.

A step in Quarantine will be unavailable for manual operation and will not be selected by the system in numeric mode.

Of course, having a step in Quarantine will reduce the load bank's total capacity accordingly and may render certain discrete load levels unobtainable.

For this reason, having one or more steps in Quarantine is incompatible with Automatic Load functions. All Automatic Load functions will be disabled if any step is under Quarantine.

Step Quarantine is meant to be a short-term solution to allow operation to continue until the load bank may be repaired.



II-H. Self-Diagnosis

The Self-Diagnosis feature is a troubleshooting tool meant to help pinpoint a deficient step.

Dependent upon system configuration certain small steps may not register correctly and may indicate a mismatch when one does not exist.

Internal/External Power: This feature considers a baseline (no steps energized) power level for internally powered units that have metering configured such that the power drawn by the cooling fan and control systems shows up in the metered power level. This is used to effectively zero the no load reading.

Start/Stop Self Diagnosis: Starting the Self Diagnosis sequence will apply the first load step and cycle through all steps as described below.

Skip Step: Moves the sequence to the next step.

When the Self-Diagnosis sequence is run, each load step will be applied individually. The system will then wait a few seconds for the power to reach its operating level, and then compare the metered level to the expected power output of the step at the current voltage.

If the step measures within 5% of its expected value, the system passes the step and moves on to the next. If it falls outside of the 5% threshold, a prompt will appear on the screen asking the operator whether to Quarantine the step.



II-I. System Status

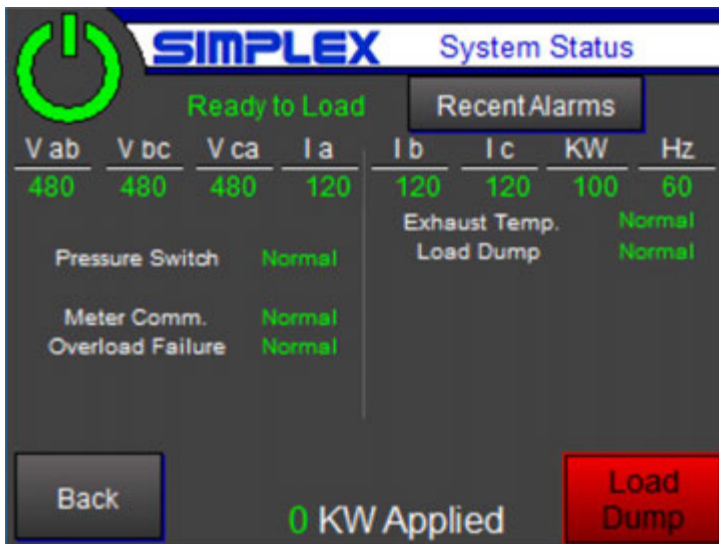

The System Status screen displays indications for all alarm and warning points, as well as all measured temperatures.

See Section II-J, Alarms and Warnings, for more details on all monitored points.

II-J. Alarms and Warnings

All alarms latch and will remain latched even if control power is turned off. Alarms can be cleared only with the Alarm Reset button. See Common Features in Section II-D-1 for more details.

Exhaust Temp Failure: The exhaust temperature high limit is calculated by the formula Unit kW capacity + 150°F (65.6°C), with a maximum of 600°F (315.6°C). An Exhaust Temp Failure will cause the unit to drop all load.

Fan Failure: Cooling fans' operation is monitored via a differential pressure sensor. Should the differential pressure across the fan drop below a threshold indicating a minimum fan speed, the unit will go into Fan Failure and all load will drop. In case of a Fan Failure, check for:

- Forward fan rotation. Ensure that fan is pulling air from the air intake side of the end of the load bank (with the Motor Disconnect Switch) and exhausting out the other end.
- Unobstructed airway. Ensure that no debris or foreign material is blocking the intake or exhaust of the airway.
- Unobstructed, uncrimped vinyl air tube between the differential pressure switch hose fitting and the fitting in the fan plenum. Caution: the pressure switch is delicate. Do not use compressed air to blow out any obstruction with tubing connected to pressure switch.

Genset Overload: If the metered frequency drops below a user-defined low frequency setpoint for a user-defined length of time, the load bank will drop all load and reset all automatic functions. The automatic functions must be selected again to restart operation.

Hatch Alarm: For units equipped with manual hatches or electrically operated vent louvers, the airway must be opened to run the cooling fan. If indication of open hatches and/or louvers is lost, the unit will drop all load and stop the fan. In case of a Hatch Alarm, ensure all hatches and louvers are open, and check limit switches on manual hatches.

Meter Failure: For units with metering. Indicates that the PLC is failing to communicate with the digital metering package. In the case of a Meter Failure, the unit may be operated manually, but automatic functions will be disabled. Check communication connections between the PLC and the meter per the drawings.

Load Dump Active: A Load Dump may be triggered from either the touchscreen or a remote, user-supplied contact. The absence of a signal through the contact will trigger a Load Dump. If a Load Dump Switch or contact has been installed, check that it is closed. If the switch or contact has not been installed, ensure that a jumper wire is in place between TB-LD 1 & 2. See Drawings for more details. Also see Section II-C-4, Miscellaneous Settings, for information on the Load Dump Bypass.

II-J. Alarms and Warnings cont'd

The following indications apply to units equipped with Auto Load Leveling and the BPM option:

BPM Warning: The PLC is receiving a signal from the user-supplied differential pressure warning sensor in the generator's exhaust stack. This signal will trigger the load bank to step its load up to the Soot Burn Window. See Section II-D-5-b, Backpressure Monitoring Operation, for more details.

BPM Alarm: The PLC is receiving a signal from the user-supplied differential pressure alarm sensor in the generator's exhaust stack. This signal will trigger the load bank to step its load up to the Soot Burn Window. See Section II-D-5-b, Backpressure Monitoring Operation, for more details.

BPM Alarm Shutdown: If the BPM Alarm signal is present for a user-defined length of time (See Section II-C-3 Backpressure Monitoring Settings, for more details), the assumption is that there is some problem with either the stack or the BPM Alarm sensor beyond a normal soot accumulation. The load bank will ramp down its load to zero and reset all automatic functions. Automatic functions must be selected again to continue operation.

II-K. Modbus or 2nd Screen Control/Monitoring

The Simplex Load Marshal control system has Modbus interconnectivity built in. Users may access many control and status points via the Modbus protocol. See drawings for communication connections. In addition, units may have a 2nd HMI option enabled where the option has been specified.

When the system is under control over Modbus, or control is taken by a 2nd HMI, control via the primary HMI will be locked out and the HMI will act as a status display for the load bank.

Enable Disable Alternate Control: Allows control to be taken by the alternate control device/returns control of the load bank to the HMI.

Modbus Control Bits/Registers:

- Unless otherwise specified, all bits should be persistent, meaning the bit should be written as a "1" for as long as the "on" state is desired.
- Modbus maps are shown with Base 1 addresses.
- Floating point values are transmitted in Big

Endian format - most significant bytes in the first word register.

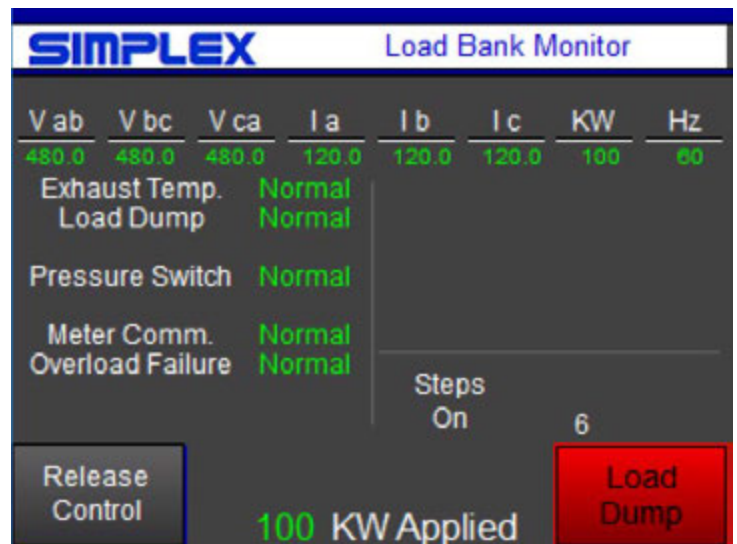

II-K. Modbus or 2nd Screen Control/Monitoring cont'd

Modbus Control Sequence of Operations

Starting the Load Bank:

1. Establish communication with Modbus RTU over serial lines or Modbus TCP/IP over a Cat-5 cable, depending on which type of communication was specified for the unit.
2. Ensure that the "Enable Alternate Control" button is engaged on the HMI.
3. Write a "1" to the "Modbus Take Control" bit.
4. Write a "1" to the "Control Power" bit. The "Startup Mode" bit should be in an on state "1" for approximately 5 seconds, after which it should toggle to "0," and the "Normal Operation" bit should toggle to "1."
5. Ensure that the load bank is ready for load by reading the "Fan Running" and "Normal Operation" bits. Both should be "1." The "Load Bank Failure" bit should be "0," as should "Load Dump Active" and "Startup Mode."
6. To secure the Load Bank after operations, reverse the process. Write a "0" to the "Control Power" bit and then to the "Modbus Take Control" bit.

Reading Meter Values: The metered values (Voltage, Current, Power, Frequency) are transmitted in Modbus registers 2000 - 2010 as 16-bit Integers and are multiplied by 10 to preserve a decimal point of precision. Divide the communicated values by 10 to get the actual metered values.

For users who prefer floating point values and can access 5-digit Modbus addresses, the same values are transmitted in Modbus registers 29471- 29491 as floating-point values with no multiplier.

Numeric Control: Numeric control is the intended mode of operation for Modbus control.

1. Write the desired kW to apply as an integer to the "kW to Apply" register.
2. Write a "1" to the "Numeric Apply Load" bit. This bit will toggle the entered amount of load on and off.
3. To change load, leave the "Numeric Apply Load" bit as a "1" and write a new value to the "kW to Apply" register.

Manual Control:

1. Write a "1" to the "Manual Master Load" bit. This bit will toggle the selected load steps on and off.
2. Write a "1" to the individual "Manual Load Step" bits to energize individual steps.

Automatic Control Modes: It is possible to trigger from Modbus control the Auto functions with which the load bank is equipped. Note that all setpoints, sequence stage definitions, etc. must be set up through the HMI as described in Section II-D-5 through 10.

1. With the desired Automatic mode completely set up per the appropriate subsections of Section II-C and II-D-5, write a "1" to the appropriate control bit (i.e. the "Enable Auto Load Level" bit. This bit acts as the "Enable Auto Level" button on the HMI. Operators should be fully familiarized with the HMI operation for any Auto function to be controlled via Modbus.

Other Control Bits: The "Alarm Reset" and "Cancel Cooldown" bits function as their HMI button analogues. See Section II-D-1, Control Screens, for more information on the buttons. To use these bits, write a "1" to the appropriate register for 1 second and then return to "0."

II-K. Modbus or 2nd Screen Control/Monitoring cont'd

Modbus Map - Controls

Base 1

Register	Modbus Address	Data Type
Modbus Take Control	8353	Bit
Control Power	8354	Bit
Manual Master Load	8355	Bit
Numeric Apply Load	8356	Bit
Cancel Cooldown	8357	Bit
Enable Auto Load Level	8358	Bit
Enable BPM	8359	Bit
Enable AEX	8360	Bit
Enable Regen	8361	Bit
Manual Step 1	8385	Bit
Manual Step 2	8386	Bit
Manual Step 3	8387	Bit
Manual Step 4	8388	Bit
Manual Step 5	8389	Bit
Manual Step 6	8390	Bit
Manual Step 7	8391	Bit
Manual Step 8	8392	Bit
Manual Step 9	8393	Bit
Manual Step 10	8394	Bit
Manual Step 11	8395	Bit
Manual Step 12	8396	Bit
Alarm Reset	8362	Bit
Enable Fixed Load	8363	Bit
Enable Auto Sequence	8364	Bit

Register	Modbus Address	Data Type
kW to Apply	1001	Int

II-K. Modbus or 2nd Screen Control/Monitoring cont'd

Modbus Map - Status

Base 1

Register	Modbus Address	Data Type
Cooldown Mode	8417	Bit
Startup Mode	8418	Bit
Load Dump Active	8419	Bit
Load Bank Failure	8420	Bit
Fan Running	8421	Bit
Normal Operation	8422	Bit
Step 1 On	8423	Bit
Step 2 On	8424	Bit
Step 3 On	8425	Bit
Step 4 On	8426	Bit
Step 5 On	8427	Bit
Step 6 On	8428	Bit
Step 7 On	8429	Bit
Step 8 On	8430	Bit
Step 9 On	8431	Bit
Step 10 On	8432	Bit
Step 11 On	8449	Bit
Step 12 On	8450	Bit
HMI Loss of Comm	8451	Bit

Register	Modbus Address	Data Type
Vab	2000	Int
Vbc	2001	Int
Vca	2002	Int
Ia	2003	Int
Ib	2004	Int
Ic	2005	Int
Hz	2007	Int
Vavg	2008	Int
kW	2009	Int
kW Applied	2010	Int

Register	Modbus Address	Data Type
Vab	29471	Float
Vbc	29473	Float
Vca	29475	Float
Ia	29477	Float
Ib	29479	Float
Ic	29481	Float
Hz	29485	Float
Vavg	29487	Float
kW	29489	Float
kW Applied	29491	Float

III. Troubleshooting

These recommended checks are meant to guide an experienced technician through investigation of a few of the most common load bank issues. A certain level of electrical knowledge and familiarity with electrical drawings is assumed.

If these checks do not pinpoint the problem, or for more information about any of the recommendations, call the Simplex Service Department at 800-637-8603.



It is sometimes necessary to have control power energized when troubleshooting in a load bank cabinet. Be aware that load banks may have multiple sources of power (test source power, fan/control power, anti-condensation heater power, etc.). Remove as much power as possible before troubleshooting. When control cabinet panels are open, treat every component and circuit as though it were live and always use all appropriate PPE.

III-A. Cooling Fan Will Not Start/Operate

- Check for presence of correct fan/control power.
- Ensure that the Motor Disconnect Switch is in the “On” Position.
- Reset Motor Disconnect Switch if tripped.
- Check that Fan Motor Contactor (FMC) closes.
- Check that the pilot relay for the FMC closes (See drawings for details).
- Ensure the PLC is in Run mode (generally, Power and Run indicators on PLC are lit).



Motor Disconnect Switch

III-B. Fan Failure Indicated

- Ensure fan is running (See above if not).
- Ensure fan is turning in the correct direction. Air should be pulled in at the bottom of the unit and exhausted out the top. If fan is spinning the wrong direction, check phasing on fan power connection.
- Check for airway obstruction at the intake and exhaust.
- Check the differential pressure switch (Located inside the control compartment of the load bank). The switch uses a length of nylon tubing to compare the pressures on each side of the cooling fan. This tube must be free of any blockage.



Differential Pressure Switch



Caution: Blowing forcefully into the differential pressure switch may damage the switch. Never use compressed air to clear the tube.

III-D. High Exhaust Temp Indicated

- Check for obstruction of airway intake and exhaust.
- Ensure that hot air is not being recirculated into the intake of the load bank.
- Ensure ample airflow. See Placement diagrams in Installation section for more detail.

III-G. HMI/PLC Comm Errors

The High Exhaust Temp Alarm pictured above is an example of a load bank system alarm. This is an alarm generated by the PLC in response to some abnormal condition.

The screen to the right is displaying an HMI generated error code in a banner across its top. This is not a system alarm, but an indication that the HMI cannot contact the PLC.

- Check communication cable between HMI and PLC
- Ensure that the PLC is in Run mode. “Power” and “Run” green LEDs should be lit.

III-H. Other HMI Issues

Other banner error codes—In addition to the PLC Communication Timeout shown above, the HMI has several different error codes it may display.

- ◆ Error codes prefaced with “PLC” as the above PLC001 indicate issues between the HMI and the PLC, either communication or data mismatch errors of some type. Make the checks listed above and call Simplex Service for assistance.
- ◆ Error codes prefaced with “RTE” (Run Time Errors) generally indicate issues within the HMI operating system itself. Two examples:
 - * RTE-002 - Log Failed. (*Device*) cannot be found.: This error will appear when the system is set up for data logging, but no USB drive is present on which to log data. This error will not affect load bank operation but may be a nuisance. Insert a data logging flash drive or ensure that the Start/Stop Logging button on the data logging screen is set to stop. See Section II-E, Data Logging, for more information.
 - * RTE-500 - SRAM Check Sum Error: The memory in the HMI has been corrupted, possibly by a power loss or other external event. The memory will have to be wiped and the program reinstalled.

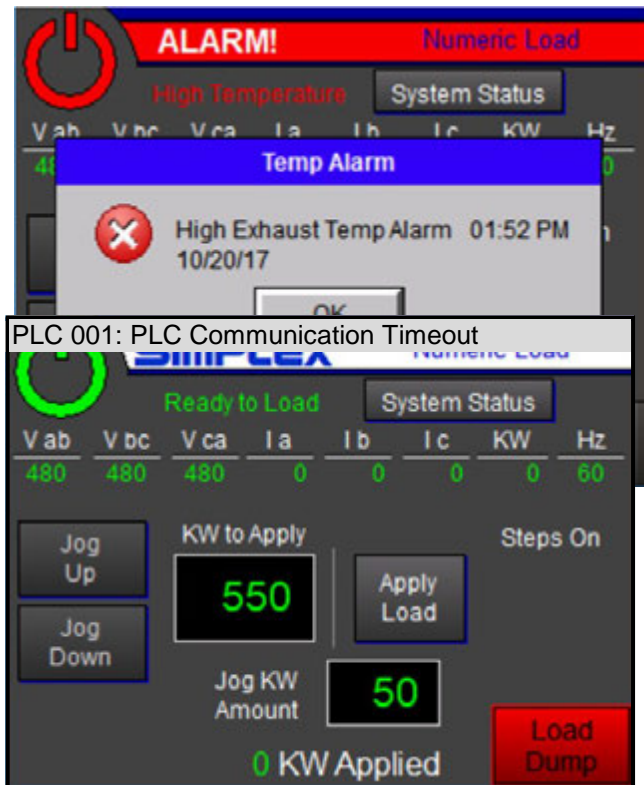

HMI Communication Error

III-H. Other HMI Issues cont'd

- Screen is black/dark:
 - ◆ Touch the screen to ensure it is not in sleep or screen saver mode.
 - ◆ Ensure there is power to the HMI.
 - ◆ Check for a bad backlight by shining a flashlight on the screen to see if screen elements appear.

III-I. Reduced kW Output or Phase Imbalance

A power output of more than 5% below the rated or expected output may indicate an issue. Many factors may contribute to a reduced load bank capacity.

- Check system voltage: A reduced voltage input will result in a derated power output, by the formula
$$kW_{\text{output}} = kW_{\text{rated}} * (V_{\text{input}} / V_{\text{rated}})^2$$
- Use manual loading or the system self-diagnostic feature to pinpoint a reduced capacity load step. The most common causes of a reduced load step capacity:
 - ◆ Check for blown load fuses - After pinpointing the affected step(s), refer to the unit's drawing package to identify the step's load fuses.
 - ◆ Check for open resistive elements - See unit's drawing package to trace element connections back to their associated Load Contactors. Using an ohmmeter, measure each phase-to-phase resistance on the load side (output side) of the contactors. The three readings (A-B, B-C, C-A) should be balanced, meaning that all three resistance readings will be virtually identical or very close to each other, and none should read open. Note that larger steps will comprise more than one contactor, so each contactor will control a segment of the step. To find the rated resistance for the segment under measurement, use the drawings to determine the rated kW value of the segment (rated step value divided by the number of segments into which the step is divided) and refer to Appendix C, Rated Resistance and Current, to determine its expected line to line resistance.
 - ◆ Check other components - a chain of control components is associated with each load step: PLC output - Pilot relay(s) - Load contactor(s)

Refer to the unit's drawing package to trace the controls. A failure at any of the control components could result in a missing, reduced capacity, or imbalanced load step.

- Check for accurate metering: See next section for information on problems with the digital metering package.

III-J. Meter Comm Error Indicated

The PLC communicates with the unit's Digital Metering Package (DMP) through a serial communication connection. If the PLC fails to communicate with the meter, a Meter Comm Failure will indicate.

- Check meter connection wiring per unit's drawing package.
- Check meter's power supply connection per unit's drawing package.

III-K. Metering Issues

Voltage: Displayed voltage zero, imbalanced or does not match system voltage:

- Check Metering Fuses MF 1-3.
- Check voltage connections from the bus to the metering transducer per unit's drawing package.

Current / kW:

- Current Zero
 - ◆ Check CT connections to meter.
 - ◆ Check ground connections on CTs.

- Current imbalanced, low, or off, or kW low, negative, or off:
 - ◆ Check CT polarity. All CTs should be installed so that the X1 / H1 side faces the source.
 - ◆ Check CT connections.
 - ◆ Check phasing. Voltage and Current inputs to the meter must be connected exactly as shown in the drawing package.

III-L. Automatic Load Leveling Issues

Automatic Load Leveling works off a kW feedback from the metering package. If the metering is not reporting kW properly, the PLC may continue adding load, looking for a user-programmed setpoint.

- Check for Metering Issues as above.
- Check Load Leveling setpoints. See Section II-C-2, Auto Load Leveling Settings, for more details.

IV. Maintenance

The load bank has been designed to require minimum maintenance. All components have been chosen for a long, reliable life. Two basic intervals of maintenance are required: each operation and Periodically. Periodic maintenance should be conducted at least every 6 months. Under high use applications (more than 50 hours of run time in less than 6 months) periodic maintenance should be conducted every 3 months. A periodic maintenance check should be conducted just after installation and any time the load bank has been relocated. Failure to conduct this maintenance can shorten the usable life of the load bank and can result in premature component failure.



Always remove all power before doing any work inside the control cabinet or other parts of the load bank. Be aware that load banks may have multiple sources of power (test source power, fan/control power, anti-condensation heater power, etc.)

IV-A. Each Operation:

- Check the air intake screens/louvers, fan and cooling chamber, and exhaust openings for any obstruction or foreign objects. Ensure that air is exiting from the exhaust vent.
- Check the entire outside of the cabinet for any visual damage, which could cause internal electrical or mechanical problems due to reduced clearance.

IV-B. Every 50 Hours or 6 Months, or after transportation:

- Inspect and operate Motor Disconnect Switch.
- Check fan blades for stress fractures.
- Check the load branches for blown fuses or open load resistors. Operate the load bank from a balanced 3-phase source and check the 3-line currents, which should be essentially the same. If a sizeable imbalance or reduced capacity is note, see Troubleshooting.
- Remove the side panel to open the control section and inspect all relays and control modules. Make sure all components are secure in their bases and safety bails are in place.
- Check tightness of all electrical connections. The expansion and contraction caused by load bank operation may over time result in loosened connections.
- Examine all accessible internal electrical components such as fuses, contactors, transformers, and relays. Check the tightness/torque of lugged wires at these components. Refer to Appendix E for torque specifications.
- Check cooling system by inspecting the fan motor and blades. Check fan blades for stress fractures. Slowly rotate blade by hand and note clearance of the blade tip through its rotation near the housing. Observe free rotation of motor shaft.
- Check the load element chamber for foreign objects, broken ceramic insulators, and mechanical damage.

The load bank's HMI will provide notification when 50 hours of operation has elapsed. Acknowledge the message to return to the previous screen.

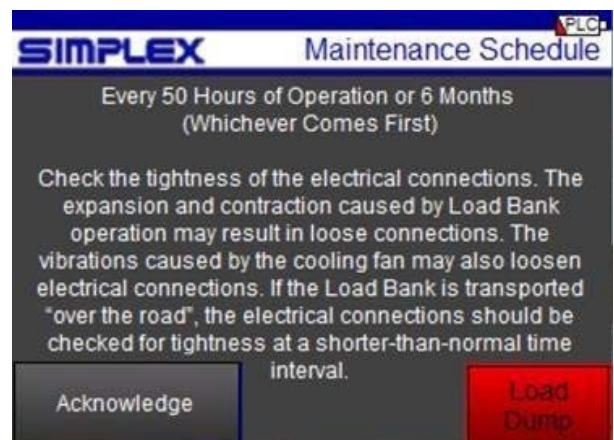

Appendix A - Rated Resistance and Current

The following tables show expected current and line to line resistance readings at common power levels for load banks of various voltage ratings operating at full rated voltage. To find values for other kW levels, use the following formulas:

$$3\emptyset \text{ Current: } (kW \times 100)/(V \times 1.732) \qquad 1\emptyset \text{ Current: } (kW \times 1000)/V$$

$$\text{Resistance: } (V^2 \times 2)/(kW \times 1000) \qquad \text{Resistance: } V^2/(kW \times 1000)$$

Note that these calculations do not take temperature into account. Elements' resistance will vary with temperature conditions.

600 V Load Bank 3 \emptyset

kW	1	5	10	20	25	50	100	200	250	500	1000
Ω	720.00	144.00	72.00	36.00	28.80	14.40	7.20	3.60	2.88	1.44	0.72
Amps	0.96	4.81	9.62	19.25	24.06	48.11	96.23	192.46	240.57	481.14	962.28

480 V Load Bank 3 \emptyset

kW	1	5	10	20	25	50	100	200	250	500	1000
Ω	460.80	92.16	46.08	23.04	18.43	9.22	4.61	2.30	1.84	0.92	0.46
Amps	1.20	6.01	12.03	24.06	30.07	60.14	120.28	240.57	300.71	601.42	1202.85

240 V Load Bank 3 \emptyset

kW	1	5	10	20	25	50	100	200	250	500	1000
Ω	115.20	23.04	11.52	5.76	4.61	2.30	1.15	0.58	0.46	0.23	0.12
Amps	2.41	12.03	24.06	48.11	60.14	120.28	240.57	481.14	601.42	1202.85	2405.70

208 V Load Bank 3 \emptyset

kW	1	5	10	20	25	50	100	200	250	500	1000
Ω	86.53	17.31	8.65	4.33	3.46	1.73	0.87	0.43	0.35	0.17	0.09
I	2.78	13.88	27.76	55.52	69.40	138.79	277.58	555.16	693.95	1387.90	2775.80

240 V Load Bank 1 \emptyset

kW	1	5	10	20	25	50	100	200	250	500	1000
Ω	57.60	11.52	5.76	2.88	2.30	1.15	0.58	0.29	0.23	0.12	0.06
Amps	4.17	20.83	41.67	83.33	104.17	208.33	416.67	833.33	1041.67	2083.33	4166.67

208 V Load Bank 1 \emptyset

kW	1	5	10	20	25	50	100	200	250	500	1000
Ω	43.26	8.65	4.33	2.16	1.73	0.87	0.43	0.22	0.17	0.09	0.04
I	4.81	24.04	48.08	96.15	120.19	240.38	480.77	961.54	1201.92	2403.85	4807.69

120 V Load Bank 1 \emptyset

kW	0.25	0.5	1	2	5	10	20	25	50	100	200
Ω	57.60	28.80	14.40	7.20	2.88	1.44	0.72	0.58	0.29	0.14	0.07
I	2.08	4.17	8.33	16.67	41.67	83.33	166.67	208.33	416.67	833.33	1666.67

Appendix B - Single Phase Configuration

Simplex stationary resistive load banks designed for three phase operation may be used (at a reduced capacity) for single phase testing when configured properly.

Three phase load banks configured for single phase operation will apply 2/3 of the load bank's 3 phase rated load.

Note that units which receive their control power from the test source may not be configured this way. Only units with a separate source of control power have this option. Also note that the metering of a unit in single phase operation will be different and therefore Automatic Load functions may not work properly.



Three phase resistive load banks may be configured for single phase according to the diagram and description in this section, but load banks with inductive or capacitive load components will not operate the same way. It is hazardous to connect or use any load bank in a manner not expressly outlined in its dedicated manual.

When operating a three-phase load bank in single phase, Single Phase Operation should be selected on the unit's HMI so that the PLC will apply a correction factor to all step values to account for the resulting capacity derate. See section II-C-4, Miscellaneous Settings for more information.

For single phase operation:

- Connect the source's L1 to the load bank's AØ.
- Connect the source's L2 to the load bank's BØ and CØ tied together.
- The source's Neutral does not connect to the load bank.

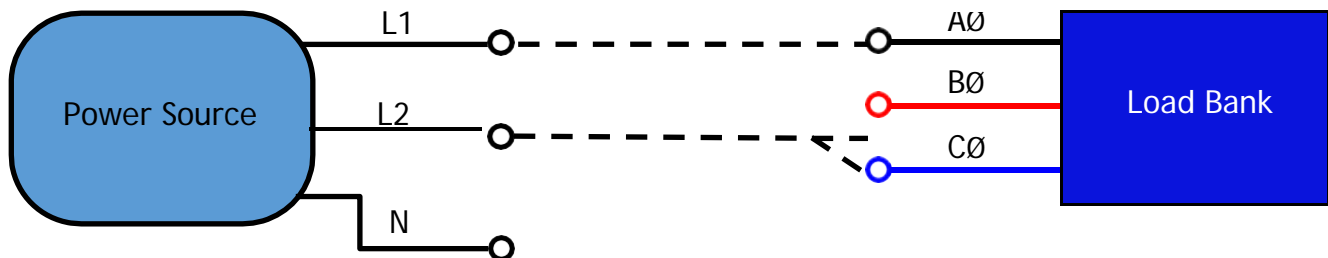

Appendix C - Torque Values

Listed in the tables below are the torque requirements for many common connections in Simplex load banks.

For third-party manufactured components such as contactors, circuit breakers, fuse blocks, etc., always adhere to the torque requirements specific to those components.

Fan Blades		
Fan Part No.	Bolt Size	Torque ft-lbs/in-lbs
13820000	Set Screw	11.7/140
13820500	Set Screw	11.7/140
13821000	Set Screw	8.3/100
13822000	1/4 - 20	7.5/90
13823000	1/4 - 20	7.5/90
13824000	1/4 - 20	7.5/90
13825100	1/4 - 20	7.5/90
13826000	1/4 - 20	7.5/90
13827500	5/16"	13/156
13827600	5/16"	13/156
73828000	3/8"	24/288

Elements/Trays		
Component	Term Nut Size	Torque in-lbs
Rod Ends	#6	4
Element Conn.	#10	20
High Voltage	1/4 - 20	Call Simplex

Main Load Blocks - All Sizes		
Connection	Wire Size	Torque ft-lbs/in-lbs
Load Side	4-14 AWG	2.9/35
Line Side	500 MCM - 4/0	31/375
	3/0 - 4/0	20/240
	2/0 - 6 AWG	10/120
	8 AWG	3.3/40

Motors, Brackets, Bus Bar Connections		
Grade	Bolt/Nut Size	Torque ft-lbs /in-lbs
Grade 5, dry	.250 (1/4 - 20)	8/96
Grade 2, dry	.250 (1/4 - 20)	5.5/66
Grade 5, dry	.312 (5/16)	17/204
Grade 2, dry	.312 (5/16)	11/132
Grade 5, dry	.375 (3/8)	30/360
Grade 2, dry	.375 (3/8)	20/240
Grade 5, dry	.437 (7/16)	50/600
Grade 2, dry	.437 (7/16)	30/360
Grade 5, dry	.500 (1/2)	75/900
Grade 2, dry	.500 (1/2)	50/600
Grade 5, dry	.562 (9/16) & up	110/1320
Grade 2, dry	.562 (9/16) & up	70/840

Miscellaneous - Terminals, Switches, Coils, Relays, Transformers, Meters	
Connection Size	Torque in-lbs
4	5
6	10
8	19
10	31
1/4 - 20	66

Cam-Lock Studs	
Connection Size	Max Torque ft-lbs
5/16" - 18	15
1/2" - 13	40



Contact Simplex
for all your Load Bank and Fuel Supply needs.

Simplex, Inc.
5300 Rising Moon Road
Springfield, IL 62711

800-637-8603
www.simplexdirect.com

This manual and all of its contents
Copyright © 2021 Simplex, Inc.
All Rights Reserved.