



NEPTUNE

**150KW-650KW
STATIONARY LOAD BANK**

Last Revision Date: June 8, 2021

For the most up-to-date information for this product and others, please contact Simplex, Inc. at (800) 637-8603 or visit us on the web at <http://www.simplexdirect.com>.

Many of the illustrations and instructions in this manual refer to the standard configuration for this product. If you have requested customizations, the drawings provided with your order take precedence; please refer to them for details specific to your order.

Table of Contents

1 Warnings and Cautions	1
Safety information symbols	1
Cautions	1
2 Nameplates and Placards	5
3 Description and Specification	9
Overview of Use	9
Control System	9
Cooling System	9
Load System	9
Safety	9
4 Unpacking	11
Included Components	11
Primary Inspection	11
5 Installation	13
Load Bank Placement	13
Installation Procedure	15
Remote HMI installation	16
Load Dump installation	17
Current Transformer installation	18
MODBUS installation	20
Heater installation	21
Dry Contacts Installation	22
6 Setup	23
General Settings	23
Automatic Mode	23
7 Operating Instructions	25
Initial start-up inspection	25
Pre-operation checks	25
Setting up the test	26
Testing operation	26
Metering (if equipped)	26
Shutdown and cooling	26
8 Automatic Mode	27
Overview	27
Setting Up Automatic Mode	28
Entering Automatic Mode	28

9	Maintenance/Troubleshooting	29
	General maintenance	29
	Every 6 Months	29
	Troubleshooting	30
10	Alarms and Warnings	31
	Alarms	31
	Warnings	31
	Appendix A Parts listings	33
	Appendix B Modbus controls	49
	Modbus Control Directions	52

Table of Figures

Current draw at specified resolutions (in kilowatts)	10
Clearance requirements	14
Conduit Opening.....	15
Ground Bus	15
Main Load Bus	15
HMI TBH.....	16
Serial Adapter	16
TB-DC	16
Load Dump Jumper.....	17
Current Transformers	18
CT Orientation	18
TB-CT.....	18
Current Transformer placement for Metering.....	19
Current Transformer placement for Auto/Regen. Mode	19
TB-COM	20
Modbus Serial Converter	20
TB-SH.....	21
TBR	22
Setup Screen	23
General Settings.....	23
Metering screen	26
Automatic/Regenerative Mode.....	27
Setup Screen	27
Automatic Mode Setup	27
Automatic Mode Running.....	28
Troubleshooting	30
Troubleshooting alarms	32
Right Subpanel Layout	33
Option D - Automation/Metering.....	34

Option B - Communication (TCP/IP Data Logging)..... 35
PLC Component list 36
Control Relays 38
Terminal Blocks..... 40
Option 010 - Space Heaters 42
Center Subpanel 44
Phase A Detail 45
Phase B Detail 46
Phase C Detail 47
Load Control Terminal Blocks 48
Modbus Controls (Read/Write) 49
Modbus Indications (Read only) 50

1 WARNINGS AND CAUTIONS

SAFETY INFORMATION SYMBOLS

The following images indicate important safety information:



This **General** warning symbol points out important information that, if not followed, could endanger personal safety and/or property.



This **Explosion** warning symbol points out potential explosion hazards.



This **Fire** warning symbol points out potential fire hazards.



This **Electrical** warning symbol points out potential electrical shock hazards.

CAUTIONS

This load bank is high-powered, technical, industrial equipment operating at dangerous voltages and temperatures. It is capable of damaging itself, property or personnel if improperly used. It is not a consumer product.

It must be installed, connected and operated by personnel properly trained and experienced in its use. An operator's manual is supplied with each load bank and available online at www.simplexdirect.com. The operator must be familiar with its contents and have access to it during operation.

- **High Voltage:** Turn off and disconnect power source before opening this equipment
- **High Temperature:** Allow hardware to cool before servicing or opening this equipment.
- **Rotating Equipment:** Ensure that the fans have stopped before opening this unit.
- **For Operator Safety:** Make sure this equipment is properly grounded when in use.

All compression-type connections on fuse blocks, load blocks, and contactors should be checked for tightness frequently. This check should be established as part of routine maintenance.

The following cautions should be observed before and during operation:

- Check intake and exhaust screens as well as fan and load elements for foreign objects.

- Position and install the load bank with consideration given to large cubic airflow requirements, exhaust temperature, and velocity. Do not point exhaust at any nearby surface or object that may be adversely affected by high temperature. This includes but is not limited to painted surfaces, tar paper and asphalt roofs, water sprinkler heads, fire alarms, and volatile material.
- Do not use in confined spaces. The load bank may have to compete with cooling air requirements of a nearby running engine generator set where cooling air intake to a confined space may not be adequate for both engine and load bank. Be especially careful not to bounce hot exhaust air off nearby obstructions for re-circulation through the load bank.
- Verify that all control switch positions are set correctly for your intended usage before connecting the load bank to the source to be tested.
- The load cables carry high amperage. Be constantly aware of possibility of inductively heating adjacent ferrous objects to temperatures sufficient to damage cable insulation.
- Always connect the safety ground cable to a proper ground. Do not rely on a possible grounded neutral somewhere else in the system.
- Routinely inspect all components and electrical connections for tightness and integrity.
- Repair any damaged or degraded components and wiring without delay.
- If technical assistance, service, or parts are needed, please call 800-837-8603 (24 Hours).
- All hardware covered by this manual have dangerous electrical voltages and can cause fatal electrical shock. Avoid contact with bare wires, terminals, connections, etc. Ensure all appropriate covers, guards, grounds, and barriers are in place before operating the equipment. If work must be done around an operating unit, stand on an insulated dry surface to reduce the risk of electrocution.
- Do not handle any kind of electrical device while standing in water, while barefoot, or while your hands or feet are wet.
- If people must stand on metal or concrete while installing, servicing, adjusting, or repairing this equipment, place insulative mats over a dry wooden platform. Work on the equipment only while standing on such insulative mats.
- The National Electrical Code (NEC), Article 250 requires the frame to be connected to an approved earth ground and/or grounding rods. This grounding will help prevent dangerous electrical shock that might be caused by a ground fault condi-



tion or by static electricity. Never disconnect the ground wire while the load bank is in use.

- Wire gauge sizes of electrical wiring, cables, and cord sets must be adequate to handle the maximum electrical current (ampacity) to which they will be subjected.
- Before installing or servicing this (and related) equipment, ensure that all power voltage supplies are completely turned off at their source. Failure to do so can result in hazardous and possibly fatal electrical shock.
- In case of accident caused by electric shock, immediately shut down the source of electrical power. If this is not possible, attempt to free the victim from the live conductor. **AVOID DIRECT CONTACT WITH THE VICTIM.** Use a nonconducting implement, such as a dry rope or board, to free the victim from the live conductor. If the victim is unconscious, apply first aid and seek immediate medical attention.
- Never wear jewelry when working on this equipment. Jewelry can conduct electricity resulting in electric shock or may get caught in moving components causing injury.
- Keep a fire extinguisher near the hardware at all times. Do NOT use any carbon tetra-chloride type extinguisher. Its fumes are toxic, and the liquid can deteriorate wiring insulation. Keep the extinguisher properly charged and be familiar with its use. If there are any questions pertaining to fire extinguishers, please consult the local fire department.
- The illustrations in this manual are examples only and may differ from your load bank.
- Main Disconnect to be provided by installer, rated 600V maximum, sized 150% maximum of rated current.
- Load Bank warranty is void if incorrectly cooled.



2 NAMEPLATES AND PLACARDS

SIMPLEX[®]
 (800) 637-8603
 www.simplexdirect.com

W.O.#: XXXXXXXX
MODEL: NEPTUNE-XXX
SHORT CIRCUIT
CURRENT RATING: 5 kA
ENCLOSURE: TYPE-3R
LARGEST MOTOR FLA: 6.5A
POWER CIRCUIT:
VOLTAGE: XXXV, 3-PH, XXHZ
FULL LOAD AMPS: XXXA

FUSE REPLACEMENT CHART

**CF1-CF4: XA, XXXV, XXXKAIC
 KLDR-X**

**F1-F21: XXA, XXXV, XXXKAIC
 JLLS-XX**

NEPTUNE-XXX
W.O. #XXXXXXX
ENVIRONMENTAL TYPE-3R

SIMPLEX[®]



SIMPLEX[®] **FORCED AIR-COOLED RESISTIVE LOAD BANK**

MODEL: NEPTUNE-XXX
CAPACITY: XXXXW AT 1.0 P.F.
COOLING: FORCED AIR
AIRFLOW: XXX CFM
MAXIMUM AIR INTAKE TEMP.: 120°F
NOMINAL AIR TEMP. RISE: 90°F-500°F MAX.
TEMPERATURE RISE: $T = \frac{KW \times 3000}{CFM}$
DUTY CYCLE: CONTINUOUS
SHORT CIRCUIT CURRENT RATING: 5KA
ENVIRONMENTAL: TYPE 3R

REMOTE CONTROL POWER CIRCUIT:
VOLTAGE: 24VDC
FULL LOAD AMPS: 2A

REMOTE CONTROL

SERIAL NUMBER: XXXXXXXX

WARNING
 High Voltage: Turn off and disconnect power source before opening any compartment
 High Temperature: Allow equipment to cool before servicing or opening any compartment
 Retaining Equipment: Assure that fan has stopped before opening any compartment
 For Operator Safety: Make sure this equipment is properly grounded when in use

All compression type connections on fuse blocks, load blocks, and contactors where used, should be checked for tightness frequently. This check should be established as a part of routine maintenance.

SIMPLEX[®] **FORCED AIR-COOLED RESISTIVE LOAD BANK**

MODEL: NEPTUNE-XXX
CAPACITY: XXXXW AT 1.0 P.F.
COOLING: FORCED AIR
AIRFLOW: XXXXX CFM
MAXIMUM AIR INTAKE TEMP.: 120°F
NOMINAL AIR TEMP. RISE: 90°F-500°F MAX.
TEMPERATURE RISE: $T = \frac{KW \times 3000}{CFM}$
DUTY CYCLE: CONTINUOUS
SHORT CIRCUIT CURRENT RATING: 5KA

VOLTAGE/CONTROL POWER CIRCUIT:
VOLTAGE: XXXVAC
CONNECTION: 3-PHASE, 3-WIRE
FREQUENCY: XXHZ
FAN POWER: INTERNAL XXXVAC
**CONTROL POWER: INTERNAL
 XXX:XXXV TRANSFORMER**
FULL LOAD AMPS: XXXA
FAN MOTOR CURRENT: 6.5A
ENVIRONMENTAL: TYPE 3R

AIRFLOW DIRECTION

SERIAL NUMBER: XXXXXXXX

WARNING
 High Voltage: Turn off and disconnect power source before opening any compartment
 High Temperature: Allow equipment to cool before servicing or opening any compartment
 Retaining Equipment: Assure that fan has stopped before opening any compartment
 For Operator Safety: Make sure this equipment is properly grounded when in use

All compression type connections on fuse blocks, load blocks, and contactors where used, should be checked for tightness frequently. This check should be established as a part of routine maintenance.

SIMPLEX™



DSW

**FAN/CONTROL POWER
DISCONNECT SWITCH**

**DISCONNECTS
FAN/CONTROL
POWER ONLY**

**ALWAYS DISCONNECT
ALL POWER SOURCES
BEFORE SERVICING
THIS EQUIPMENT**



**HEARING
PROTECTION
REQUIRED**

WARNING - DANGER - WARNING

High Voltage: Turn off and disconnect power source before opening this compartment

High Temperature: Allow equipment to cool before servicing or opening this compartment

Rotating Equipment: Assure that fan has stopped before opening this compartment

For Operator Safety: Make sure this equipment is properly grounded when in use

All compression type connections on fuse blocks, load blocks, and contactors where used, should be checked for tightness frequently. This check should be established as part of routine maintenance.

**WARNING
FOR OPERATOR
SAFETY MAKE SURE
THIS EQUIPMENT IS
PROPERLY GROUNDED
WHEN IN USE.**



3 DESCRIPTION AND SPECIFICATION

OVERVIEW OF USE

Simplex Neptune load banks are precision test instruments designed to apply a selectable load to a power source and measure the source's response. They are used for routine maintenance exercise to ensure the long-term reliability and readiness of the standby generator. Load banks can also eliminate the detrimental effects of unloaded operation of diesel engine generators as well as prevent damage from reverse power generation.

Neptune load banks are available in models ranging from 150 kilowatts up to 650 kilowatts. All standard Neptune models have a step resolution of 5 kilowatts.

Standard Neptune units are designed to operate in ambient temperatures between 5 and 125 degrees Fahrenheit. For colder temperatures, an Arctic Duty load bank is required.

CONTROL SYSTEM

Neptune load banks feature a Human-Machine Interface (HMI) touchscreen, which controls load bank operation and displays the unit's status. With the HMI, the operator can apply a desired load and measure the response of the test source.

The load bank can also be integrated into your facility's BMS/BAS system via standard Modbus RS-485 or optional Modbus TCP/IP, as well as a set of dry contacts for status reporting.

COOLING SYSTEM

Neptune load banks are cooled by forced air, delivered by an aluminum fan blade directly driven by a TEFC motor. The air is brought in on the bottom of the load bank and expelled through the top. Optional equipment allows the exhaust to be driven through a customer-installed duct, providing for indoor installation.

LOAD SYSTEM

The load system comprises independently controlled Simplex Powr-Web resistors, which have been designed specifically for use in load bank systems. The load elements are supported by high-temperature, ceramic-clad, stainless-steel rods across their entire length, virtually eliminating element-to-element short circuits. The elements are arrayed in discrete trays, which are independently serviceable.

SAFETY

The Neptune is protected by sensors to ensure that the load bank is sufficiently cooled and that the exhaust does not exceed a safe temperature, which could damage the load bank or present

a safety hazard to the operator. When a failure occurs, the safety system immediately removes the load to protect the equipment from permanent damage.

Table 1 Current draw at specified resolutions (in kilowatts)

		150	200	250	300	350	
1-phase	208V	721A	N/A	N/A	N/A	N/A	
	240V	625A	N/A	N/A	N/A	N/A	
3-phase	208V	416A	555A	694A	N/A	N/A	
	240V	361A	481A	601A	722A	N/A	
	416V	208A	278A	347A	416A	486A	
	480V	180A	241A	301A	361A	421A	
	600V	144A	192A	241A	289A	337A	
		400	450	500	550	600	650
1-phase	208V	N/A	N/A	N/A	N/A	N/A	N/A
	240V	N/A	N/A	N/A	N/A	N/A	N/A
3-phase	208V	N/A	N/A	N/A	N/A	N/A	N/A
	240V	962A	N/A	N/A	N/A	N/A	N/A
	416V	555A	625A	694A	763A	N/A	N/A
	480V	481A	541A	601A	662A	722A	782A
	600V	385A	433A	481A	529A	577A	626A

These measurements are based on ideal numbers. They do not take into account control power draw, power cable resistance, voltage droop, etc.

4 UNPACKING

INCLUDED COMPONENTS

The following items are included with your load bank. If any of the following are not included, please contact Simplex Direct at 800-637-8603.

1. Load bank
2. Controller (remote or local)
3. Manual
4. Drawing package

Optional equipment

1. Additional controllers
2. Exhaust hood
3. Current transformers
4. Other optional equipment

PRIMARY INSPECTION

Before installing your Neptune, inspect the shipping crate and load bank. Physical or electrical problems could arise from handling and vibration. Never apply power to a load bank before performing this procedure. The following five-point inspection is recommended before installation and as part of a 6-month maintenance schedule or when the load bank is relocated:

If any problems are observed during Primary Inspection, call Simplex 24 hours a day at 800-637-8603

1. If the crate shows any signs of damage, examine the load bank in the corresponding areas for signs of initial problems.
2. Check the entire outside of the cabinet for any visual damage, which could cause internal electrical or mechanical problems due to reduced clearance.
3. Open the control panel door and inspect all relays and control modules. Make sure all components are secure in their bases and safety bails are in place. Spot check electrical connections for tightness. If any loose connections are found, inspect and tighten all remaining connections.
4. Examine all accessible internal electrical components such as fuses, contactors, and relays. Check lugged wires at these components.
5. Check the load element chamber for foreign objects, broken ceramic insulators, and mechanical damage.

5 INSTALLATION

LOAD BANK PLACEMENT

Improperly installing this unit may result in damage or destruction of the load bank, adjacent equipment, and the building housing the unit.



Normally equipped, Neptune load banks are intended for outdoor installation. A forced air system, which discharges out of the top of the unit, cools the load elements (See **Figure 1 Air Flow**.) Load banks require large quantities of air circulation, so it is essential to install the unit in an area that provides adequate airflow. Before conducting load tests, a review of site conditions by trained personnel is recommended.

The load bank requires at least 6 feet of clearance on the front, left, and right sides; and 1.5 feet of clearance in the rear (see **“Figure 2 Clearance requirements”** on page 14). Because of the high exhaust temperature, do not install anything above the load bank or install the load bank under existing installations or in environments where objects such as tree branches would be above the unit.

The load bank should be placed in a secure area accessible by trained personnel only.

Because the unit generates a lot of heat, never operate near sprinkler systems.

Operating the load bank in a confined space will recycle hot exhaust air through the cooling system, which can cause severe damage.

The load bank may compete with nearby generators for cooling air.

Figure 1 Air Flow

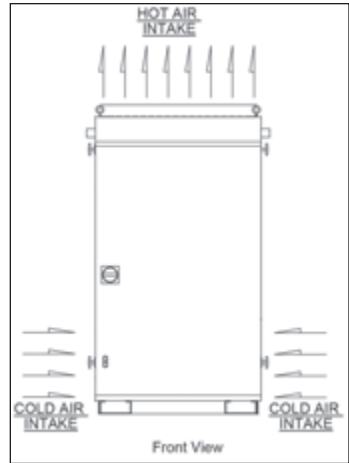
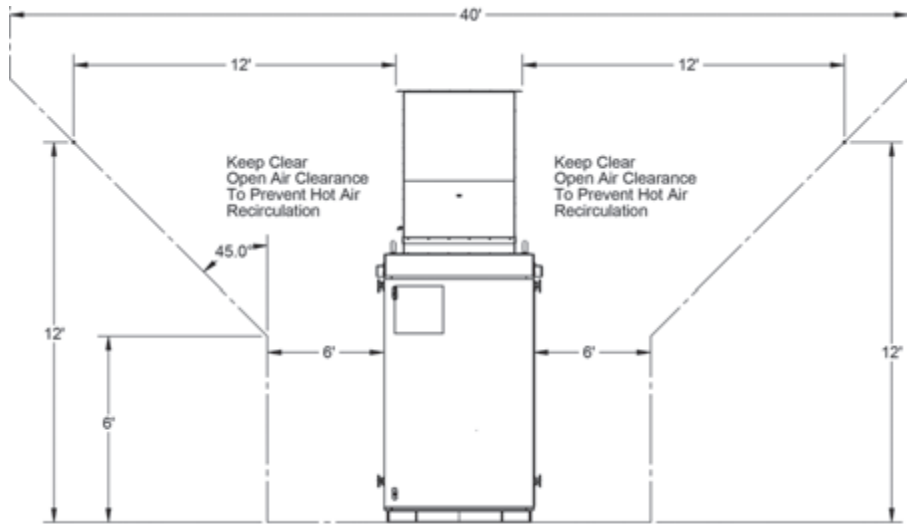
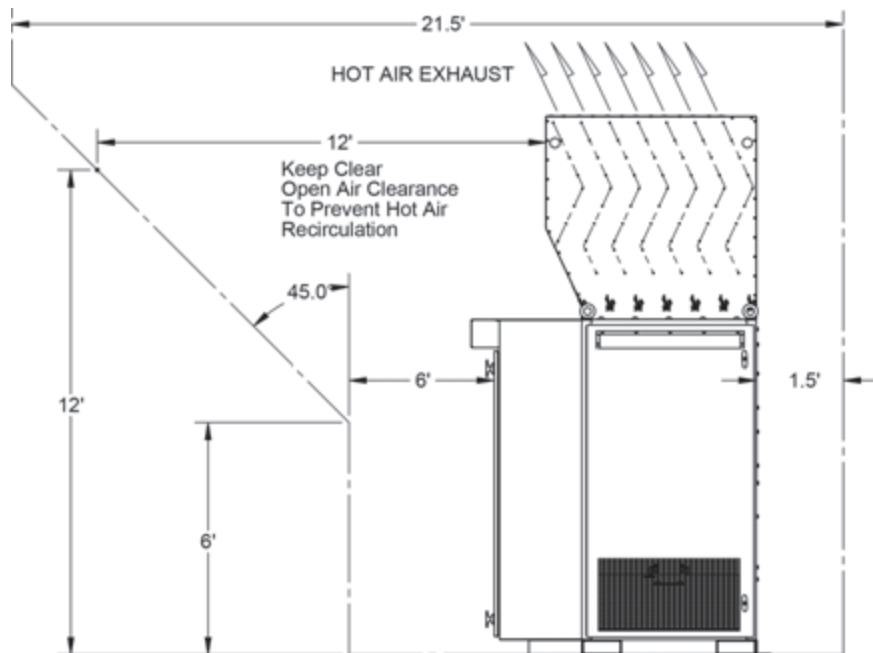

Figure 2 Clearance requirements



VIEW - FRONT
Clearance Profile - Not To Scale



VIEW - Right Side
Clearance Profile - Not To Scale

INSTALLATION PROCEDURE

Neptune load banks feature a power outlet in the control panel for your use. This outlet is limited to 2 amps.

1. To bring in the source's power cables, cut holes in the Conduit Opening, located in the bottom of the load bank's control panel enclosure (see **Figure 5 Conduit Opening**).
2. Confirm the test source is properly grounded.
3. Ground the load bank by connecting the Grounding Bus to an earth ground or grounding rod. See **Figure 3 Ground Bus**
4. Connect the source's power output to the load bank via the Main Load Bus with appropriately sized cables (see **Figure 4 Main Load Bus**).

Figure 3 Ground Bus



Figure 4 Main Load Bus



Figure 5 Conduit Opening

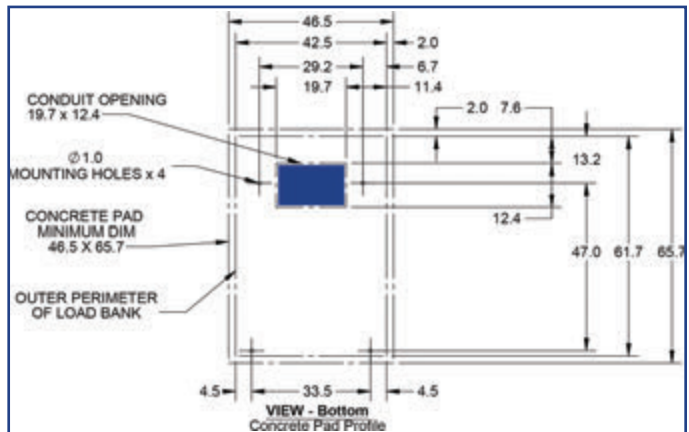

REMOTE HMI INSTALLATION

If your HMI is installed directly on the load bank, skip to the next section.

1. Mount the HMI where desired.
2. Connect the HMI to the Load Bank by swinging the HMI's screen out to expose the TB-H terminal block (see **Figure 6 HMI TBH**) and wiring it to the Load Bank.

A. Using a Belden 9841 or equivalent cable, make the following connections between the HMI's TB-H terminals to the Serial Adapter (see **Figure 7 Serial Adapter**).

1. TB-H 4 → TXD+
2. TB-H 5 → TXD-
3. Wire shielding → COM B

B. Using a copper wire, 14AWG or larger, rated at 60C or higher, connect the HMI's TBH 1 to the load bank's TB-DC 1 terminal and the HMI's TBH 2 to the load bank's TB-DC 3 terminal (see **Figure 8 TB-DC**).

Figure 6 HMI TBH

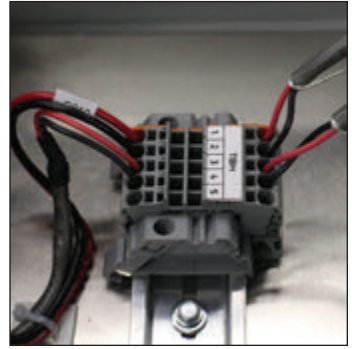
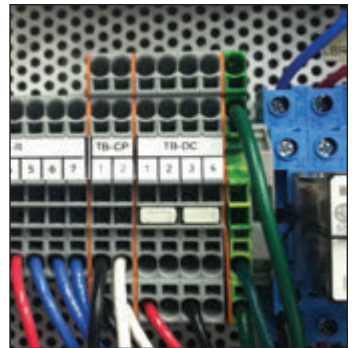

Figure 7 Serial Adapter



Figure 8 TB-DC



LOAD DUMP INSTALLATION

If the Load Dump feature is desired, remove the factory-installed jumper at TB-R 1-2 and connect customer-supplied Load Dump contacts to TB-R 1-2 (See **Figure 9 Load Dump Jumper**). To dump the load, open the customer-supplied contact. To enable load, close the customer-supplied contact.

Figure 9
Load Dump Jumper

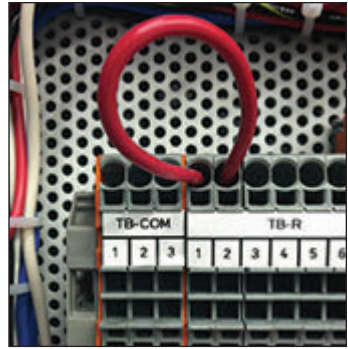

CURRENT TRANSFORMER INSTALLATION

If your load bank is equipped with Metering, Automatic Mode or Regenerative Mode options, you will have to install current transformers on your power cable.

- For metering mode, install the current transformers on the load bank leg of your power system (see “[Figure 13 Current Transformer placement for Metering](#)” on page 19.)
- For Automatic/Regenerative Mode, install the current transformers on the power source leg (see “[Figure 14 Current Transformer placement for Auto/Regen. Mode](#)” on page 19.)

The current transformers must be placed and oriented correctly to ensure they accurately detect the current. The first current transformer must be installed on Phase A, and the second must be installed on Phase C.

Orient the current transformers so that the XI or HI on each ring is facing the power source (see [Figure 11 CT Orientation](#).)

When the current transformers are installed, connect them to the load bank by connecting the white wire of the current transformer on Phase A to TB-CT 1 and the black wire to TB-CT 2. If a second current transformer is installed on Phase C, connect its white wire to TB-CT 3 and its black wire to TB-CT 4 (see [Figure 12 TB-CT](#).)

Figure 10
Current Transformers



Figure 11
CT Orientation



Make sure the XI or HI on the ring faces the power source.

Figure 12 TB-CT



Figure 13
Current
Transformer
placement for
Metering

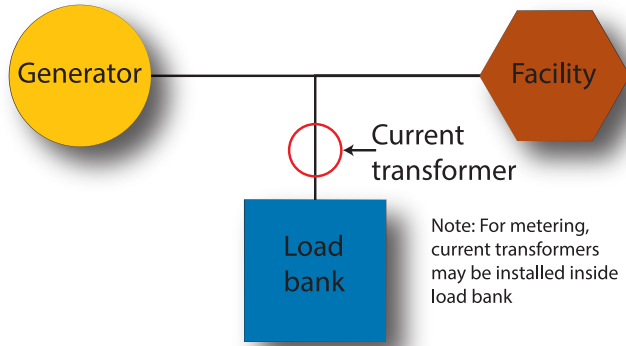
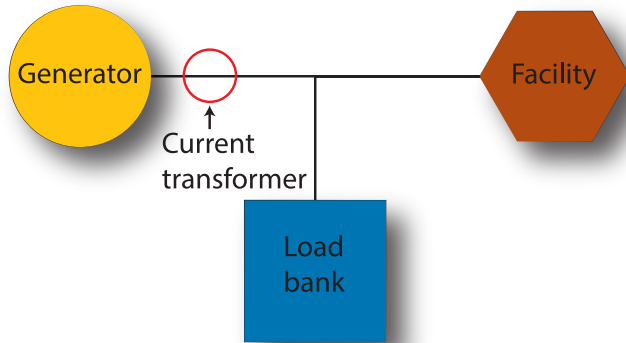

Figure 14
Current
Transformer
placement for
Auto/Regen.
Mode



The first current transformer must be installed on Phase A, and the second must be installed on Phase C.

MODBUS INSTALLATION

The Neptune load bank supports the Modbus protocol, implemented either as RS485 or TCP/IP (which is an optional upgrade).

To implement Modbus control and monitoring, connect the load bank to your facility's systems as follows:

For RS485:

1. Connect the RS485+ line to TB-COM 1
2. Connect the RS485- line to TB-COM 2
3. Connect the wire shielding to TB-COM Terminal 3

For Optional Modbus TCP/IP

1. Plug a CAT5e cable into the ethernet jack on the MODBUS Serial Converter (see [Figure 16 Modbus Serial Converter](#).)

The Neptune Modbus control set is implemented as detailed in [“Appendix B — Modbus controls” on page 49](#)

Figure 15 TB-COM

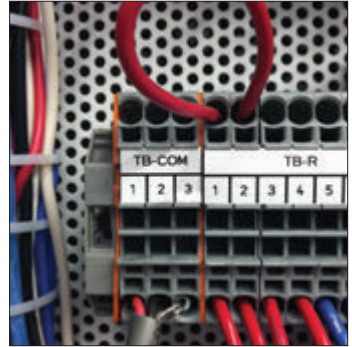
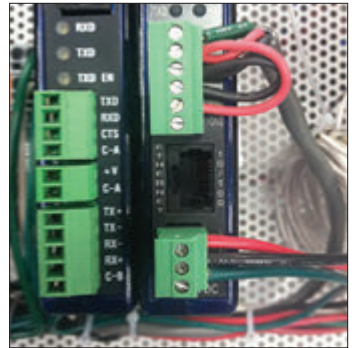

Figure 16 Modbus Serial Converter



HEATER INSTALLATION

Neptune load banks are equipped with space heaters for cold weather operation and to prevent condensation, which can damage the unit. The heaters require a dedicated power source independent of control power at all times to prevent startup failure due to cold environments.

To run power to the heaters:

1. Run a 120V, 15A, 1-phase power cable into the control panel.
2. Connect the Line leg of the power cable to SH-1
3. Connect the Neutral leg of the power cable to SH-2
4. Connect the Ground leg of the power cable to SH-3

The heaters are set at 50 degrees Fahrenheit. If a different temperature is required, adjust the red thermostat on the front of the heater.

Figure 17 TB-SH



DRY CONTACTS INSTALLATION

The Neptune provides a set of Remote Signal Dry Contacts, which provide an alarm message to let you know if the load bank has failed.

To use the dry contacts, wire three cables to TBR-5-7. Continuity between TBR-5 and TBR-6 indicate normal load bank operation, and continuity between TBR-5 and TBR-7 indicate load bank failure.

Figure 18 TBR



6 SETUP

Neptune load banks feature a power outlet in the control panel for your use. This outlet is limited to 2 amps.

The Neptune load bank offers a number of configuration options through its setup screens. You can access the setup screens by pressing “F4 - Setup” or the F4 function key.

At the main setup screen, you are presented with four options:

1. General Settings
2. Automatic Mode Settings
3. Test Mode (Intended only for Simplex engineers)
4. Factory Setup (Intended only for Simplex engineers)

You can access General Settings and Automatic Mode Settings by pressing their respective buttons.

GENERAL SETTINGS

General Settings presents three fields:

1. Cooldown Delay (sec)
2. Intake Temp Warning (F)
3. Exhaust Temp Alarm (F)

Cooldown Delay should not normally be changed.

Cooldown Delay determines how long the load bank fans will continue running after an operation has been concluded. Intake Temp Warning determines at what temperature the load bank will present a warning that the air being used for the forced air cooling system is too hot.

Exhaust Temp Alarm determines how hot the exhaust must be before the load bank will trigger an Exhaust Temp High alarm and remove the load. This and Intake Temp Warning may need to be changed at installation, depending on the climate.

AUTOMATIC MODE

Automatic Mode Settings specify the operation of Automatic/Regenerative Mode. For information about how to set them up, see **“Setting Up Automatic Mode” on page 28.**

Figure 19 Setup Screen

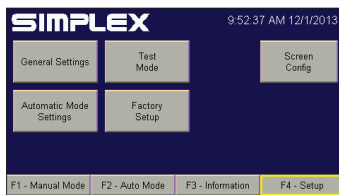
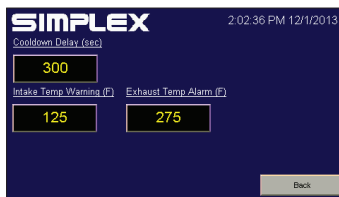

Figure 20 General Settings



7 OPERATING INSTRUCTIONS

INITIAL START-UP INSPECTION



Disconnect all power before performing the initial start-up inspection

Before turning on the load bank for the first time, inspect the unit to ensure safe and proper operation.

1. Open control panel access door and check for any abnormalities.
2. Check for and correct any loose connections in control panel.
3. Remove any foreign objects from the control panel enclosure.
4. Spin the cooling fan blade by hand to ensure it clears the fan shroud.
5. Remove any foreign objects from element chamber.
6. Ensure circuit breaker is closed and ready to provide control power to load bank.

Figure 21 Fan/Control Power Disconnect Switch



Figure 22 Control Power Button



Figure 23 HMI - Manual Mode



PRE-OPERATION CHECKS

Neptune load banks feature a power outlet in the control panel for your use. This outlet is limited to 2 amps.

1. Start the generator or source being tested.
2. Ensure the load bank's Fan/Control Power Disconnect Switch, located on the unit's door, is in the on position (see [Figure 21 Fan/Control Power Disconnect Switch](#).)
3. Check the load bank's intake areas, located on the bottom of the unit, to ensure that the vents are not blocked by paper or other debris that would prevent the cooling fan from pulling in air.
4. On the HMI, turn on the load bank by pressing the Control Power button in the upper left corner of the screen (see [Figure 22 Control Power Button](#).)
5. Listen to the load bank's fan to ensure it is operating normally.

SETTING UP THE TEST

When the fan is running properly, you are ready to begin testing.

Press the F1 function key or “F1 - Manual Mode” on the screen to bring up Manual Mode (See **Figure 23 HMI - Manual Mode**). In the upper right area of this screen is a display indicating the load to be applied, measured in kilowatts. To change this value, touch the number and enter the new value on the numeric keypad that appears. Enter the desired value and press the \checkmark button to return to the previous screen, or press “Esc” to return to the main screen without changing the value.

In the lower right quadrant of the screen is the KW Jog value. This indicates by how many kilowatts you will increase or decrease the load by pressing the “-” and “+” buttons, respectively. To change this value, press the number and enter your choice using the numeric keypad.

Figure 24 Metering screen

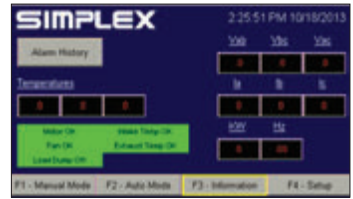

TESTING OPERATION

To begin testing, press the “Master Load” button. This will activate the load bank and begin applying the load displayed in the upper right area of the screen. To quickly decrease or increase the load, press the “-” and “+” buttons.

METERING (IF EQUIPPED)

If you have purchased the metering upgrade, pressing the F3 function key or “F3 - Information” on the screen while the test is running will bring up the metering screen (see **Figure 24**). Here you can monitor the voltage, current, load applied to the source, and the frequency of the electricity. This screen also displays the temperatures registered by the load bank’s three sensors.



If any of three voltage or current values are significantly different from the other two, check the load bank for a blown fuse. If no blown fuse is found, contact Simplex service at 800-637-8603.

Pressing “Alarm History” on this screen will bring up a list of registered alarms.

SHUTDOWN AND COOLING

When the test is complete, press the Master Load button then the Control Power button to remove the load from the test source. The load bank’s fan will continue running for the duration of the cooldown delay (see **page 23**).

8 AUTOMATIC MODE

The Neptune load bank can be equipped with an optional automatic mode, which will extend your generator's life by protecting it against wet-stacking and reverse current.

Figure 25 Setup Screen

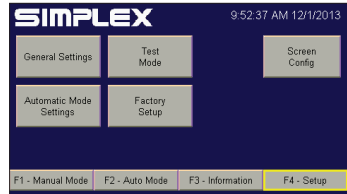

OVERVIEW

Automatic Mode adds load when the load bank detects that your generator isn't operating in its optimal range.

When your load bank is installed, a set of current transformers will be installed on your generator's power lines to monitor the load on your system. When the load bank detects that the power draw has fallen below a preset range, it begins adding load until the draw on the generator is within the designated range. Should the load bank determine that the

Figure 26 Automatic Mode Setup

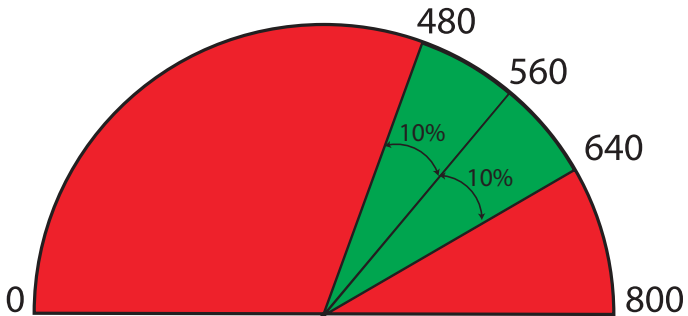
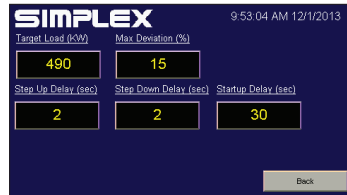
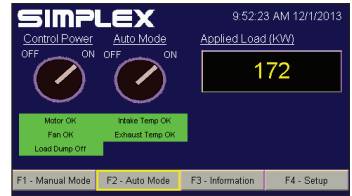

Figure 27 Automatic/Regenerative Mode

In this illustration, the load bank has been set up for an 800KW generator. The Target Load is set at 560KW, with 10% Max Deviation. So long as the load remains in the green area, the load bank will not add or drop load. But if the load moves into the red area, the load bank will adjust the load to move it back into the green.

Figure 28 Automatic Mode Running



power draw has increased beyond the preset maximum value, it begins removing load until the draw is back within the designated range.

SETTING UP AUTOMATIC MODE

The values you will need to set up this mode are specific to your generator. For example, if you have an 800 kilowatt generator with a 60% to 80% optimal operating range, you might set Target Load to 560 (which is 70% of its capacity) and Max Deviation to 10%.

Before you activate Automatic Mode, you must configure the load bank to interact with your generator. Enter the Automatic mode setup screen by pressing the “F4 Setup” button on the screen or the F4 function key to reach the Setup Screen, then pressing the Automatic Mode Settings button (see “[Figure 25 Setup Screen](#)” on page 27.)

On the setup screen will be five options specific to Automatic Mode. (See “[Figure 26 Automatic Mode Setup](#)” on page 27.)

- **Target load (KW):** Sets the target load you want on your generator, measured in whole kilowatts.
- **Max Deviation (%):** Determines how far above and below your target load is acceptable, measured in whole percentage points. This value must be greater than your load step resolution.
- **Step Up Delay (sec):** Determines how fast the load bank will add sequential load steps, measured in whole seconds.
- **Step Down Delay (sec):** Determines how fast the load bank will remove sequential load steps, measured in whole seconds.
- **Startup Delay (sec):** Determines how long the unit will wait before beginning to regulate the load once the power draw has dropped below the lower limits established by Target Load and Max Deviation, measured in whole seconds.

To change any of the values, press the value and a numeric keypad will come up. Use it to enter a new value the same way you would enter a load to apply.

ENTERING AUTOMATIC MODE

When your load bank is configured, return to the main screen by pressing the “Back” button. From the Main screen, press the “F2 - Auto” button or the F2 function key to enter the Automatic Mode screen (See [Figure 28 Automatic Mode Running](#).)

On the Automatic Mode screen, press the “Auto Mode” switch. Once this mode is enabled, the load bank will monitor your generator and step the load up or down as necessary.

Once configured and enabled, your load bank can remain in Automatic Mode indefinitely.

9 MAINTENANCE/TROUBLESHOOTING

GENERAL MAINTENANCE

Simplex load banks are designed to require minimum maintenance. All components have been chosen for a long, reliable life. Most problems can be avoided by simply keeping the control panel enclosure clear of any debris or foreign objects and ensuring all electrical connections are tight.

Tighten the electrical connections:

1. After the first use
2. After the fifth use
3. Every 6 months thereafter

EVERY 6 MONTHS

- Check the air intake screens and louvers, fan and cooling chamber, and exhaust openings for any obstructions or foreign objects.
- Check fan blades and fan shroud for stress fractures.
- Check the exhaust vent for obstructions
- Check the load branches for blown fuses or opened load resistors.

To check the fuses or load resistors, operate the load bank from a balanced 3-phase source and check the three line currents. The three current readings should be essentially the same. If a sizable difference is noted, one or more load fuses or load resistors may have malfunctioned.



Remove all power from the load bank before servicing the unit.

Visually inspect the wiring and contactors in the control panel area and wiring in the load element trays for signs of loose connections. Indications of loose connections include:

1. Discolored wires
2. Black or white discoloration on contactors
3. Signs of electrical arcing.

For a comprehensive inspection, operate the load bank for five minutes, then shut it off and conduct a thermal scan of the control panel area. Loose connections will show up as bright areas on the thermal scan.

TROUBLE SHOOTING

Although Neptune load banks are designed with trouble-free operation in mind, some problems can arise. Please consult the following table for solutions to the most common issues before contacting a Simplex service representative.

Table 2 Troubleshooting

Problem	Solution
Load bank wired to source but won't turn on	Ensure load bank is wired to source correctly Check for and replace any blown fuses Tighten any loose relays, contactors, lugged wires, etc.
Load bank overheating	Clear intake and exhaust vents of any debris Ensure load bank was not installed too close to generator or any other source of exhaust Ensure load bank was installed in a location that allows sufficient cool air intake and exhaust Make sure ambient temperature isn't too high to allow for cool air flow
HMI not displaying data	Ensure HMI power connections are wired correctly Check HMI serial cable connections

10 ALARMS AND WARNINGS

Neptune load banks are protected by four types of sensors.

1. Intake temperature, which checks the incoming air to ensure the load elements can be adequately cooled.
2. Exhaust temperature, which checks the air temperature coming out the load bank.
3. Fan pressure, when ensures the fan blades are forcing air into the load element chamber.
4. Fan current, which ensures the fan motor isn't overloaded or jammed.

ALARMS



Unresolved cooling issues may result in damage to the load bank.

The Neptune load bank's HMI features five status areas:

- **Motor:** Indicates the status of the cooling fan motor
- **Fan:** Indicates whether the fan is blowing air into the element chamber
- **Intake Temp:** Indicates status of incoming cooling air
- **Exhaust Temp:** Indicates status of load bank's exhaust
- **Load Dump:** Indicates whether the load dump feature has been activated

With the exception of Intake Temp, any failure state will cause the unit to dump the load until the problem is fixed.

The load bank will alert you to alarms by turning the status areas for the alarm on the home screen from green to red and displaying the alarm signal in white text.

WARNINGS

The Neptune features one warning: Intake Temp High. When this warning is triggered, the Intake Temp status area will turn yellow.

Neptune load banks do not dump load when a warning is triggered, but the problem should be investigated as soon as possible.

Table 3 Troubleshooting alarms

Alarm	Cause	Solution
Motor	Fan blades blocked	Clear obstruction
	Intake vents blocked by debris, paper, etc	Clear intake vents
Fan	Fan blades have come loose from shaft	Tighten fan blade hub.
	Intake vents blocked by debris, paper, etc	Clear intake vents
Intake Temp	Load bank pulling in exhaust from generator, etc.	Ensure load bank was not installed too close source of exhaust
	Insufficient airflow	Ensure load bank has access to sufficient cool air intake
	Ambient temperature too high	Conduct operation on cooler day, if possible
Exhaust Temp	Air not being forced over load elements	Ensure fan and fan motor are working correctly and rotating in correct direction
Load Dump	Load dump switch activated	Deactivate load dump switch
	Load dump jumper fell out of TB-LD 1-2	Replace load dump jumper

APPENDIX A — PARTS LISTINGS

Figure 29 Right Subpanel Layout

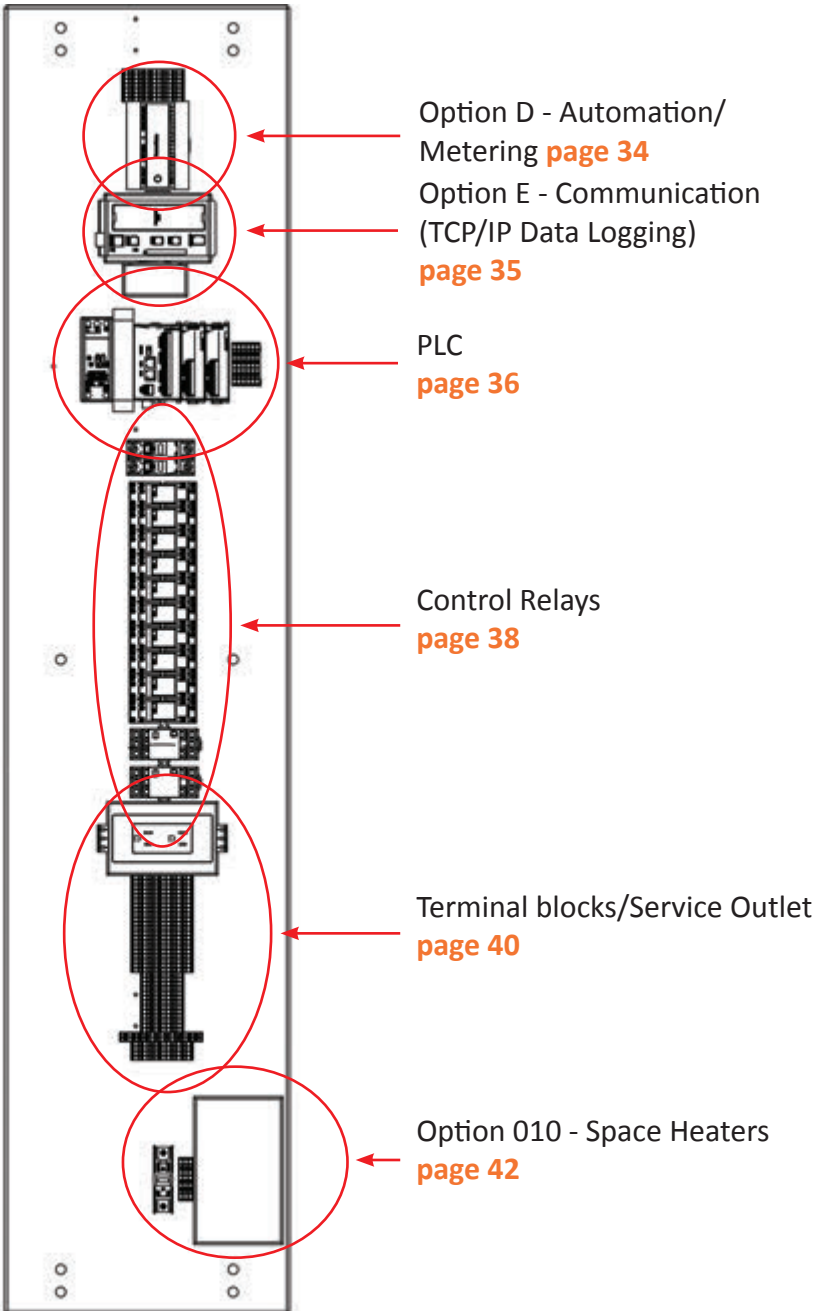

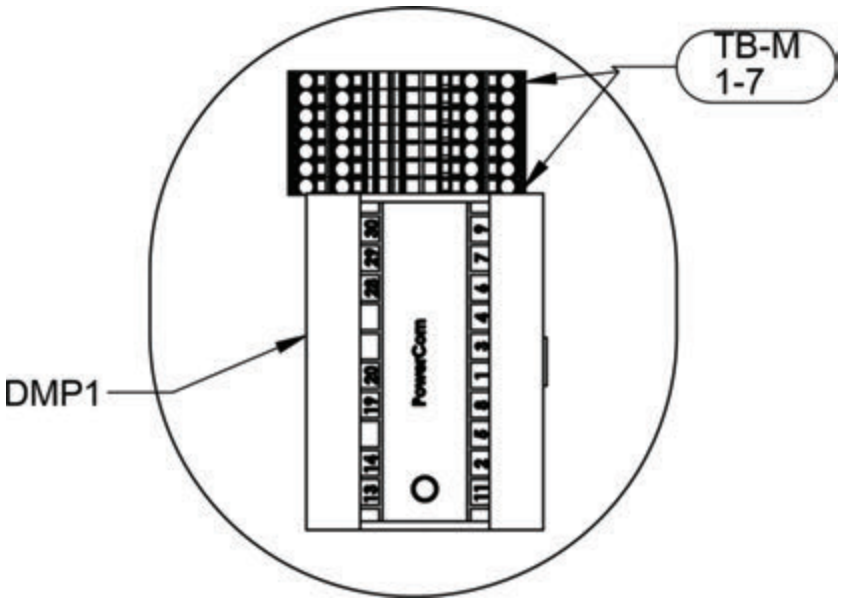

Table 4 Option D - Automation/Metering

Label	Description	Part Number
TB-M 1	Terminal Block, 4 Connections, Black	25678547
TB-M 2	Terminal Block, 4 Connections, Red	25678546
TB-M 3	Terminal Block, 4 Connections, Blue	25678557
TB-M 4, 6	Terminal Block, 4 Connections, Grey	25678536
TB-M 5, 7	Terminal Block, 4 Connections, Green	25678537
DMP1	Digital Metering Package, RS232	24345050

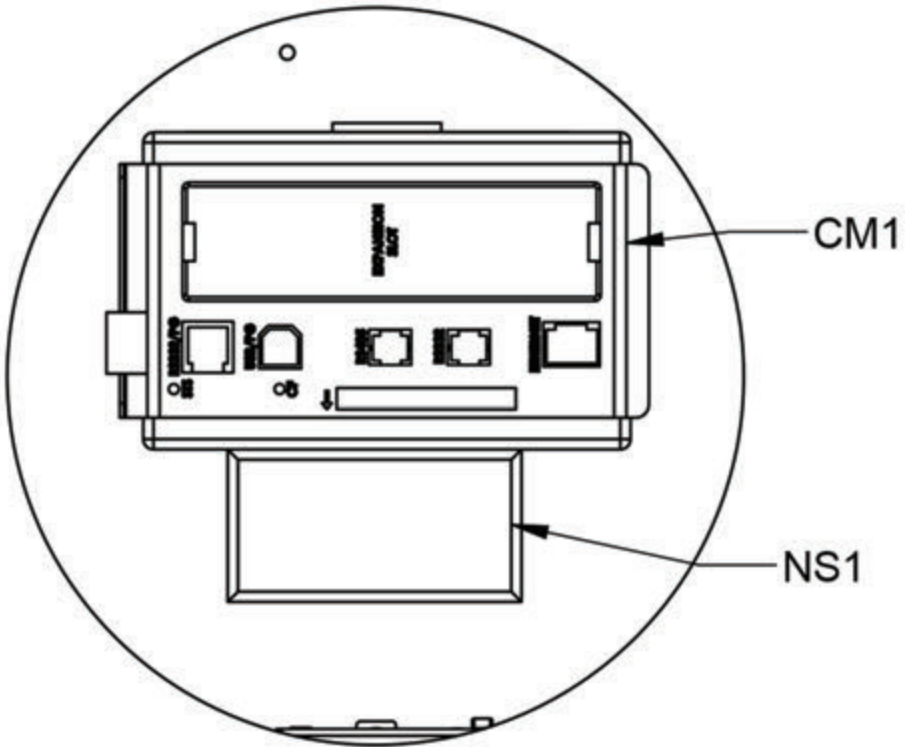

Table 5 Option B - Communication (TCP/IP Data Logging)

Label	Description	Part Number
CM1	Modular Controller and Protocol Converter	24955043
NS1	Ethernet Switch, 5 Port, Unmanaged	24955074

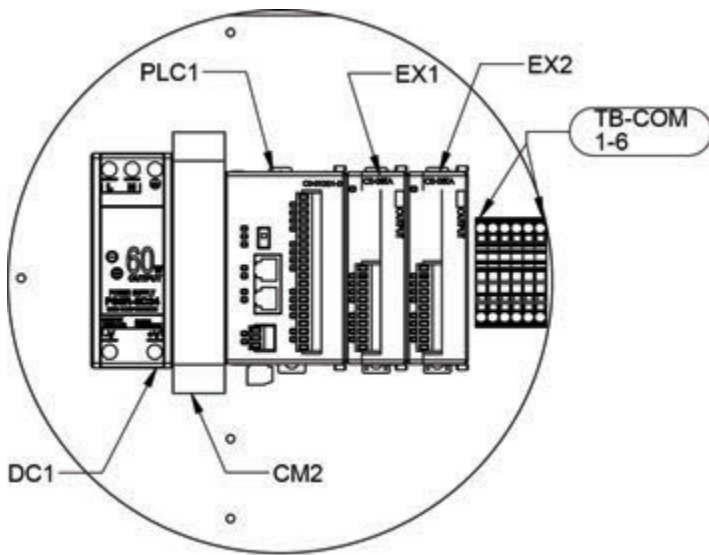

Table 6 PLC Component list

Label	Description	Part Number
PLC1	PLC	24955113
EX1	8PT Relay Output Module	24955008
EX2	4PT Thermocouple Input Module	24955023
DC1	DC Power Supply, 60W, 24VDC	25457900
CM2	RS232/RS485 Converter, RJ12 Port	24953500
TB-COM1-6	Terminal Block, Spring Type, 20A, 600Vac, 2 Connections, Grey	25678532

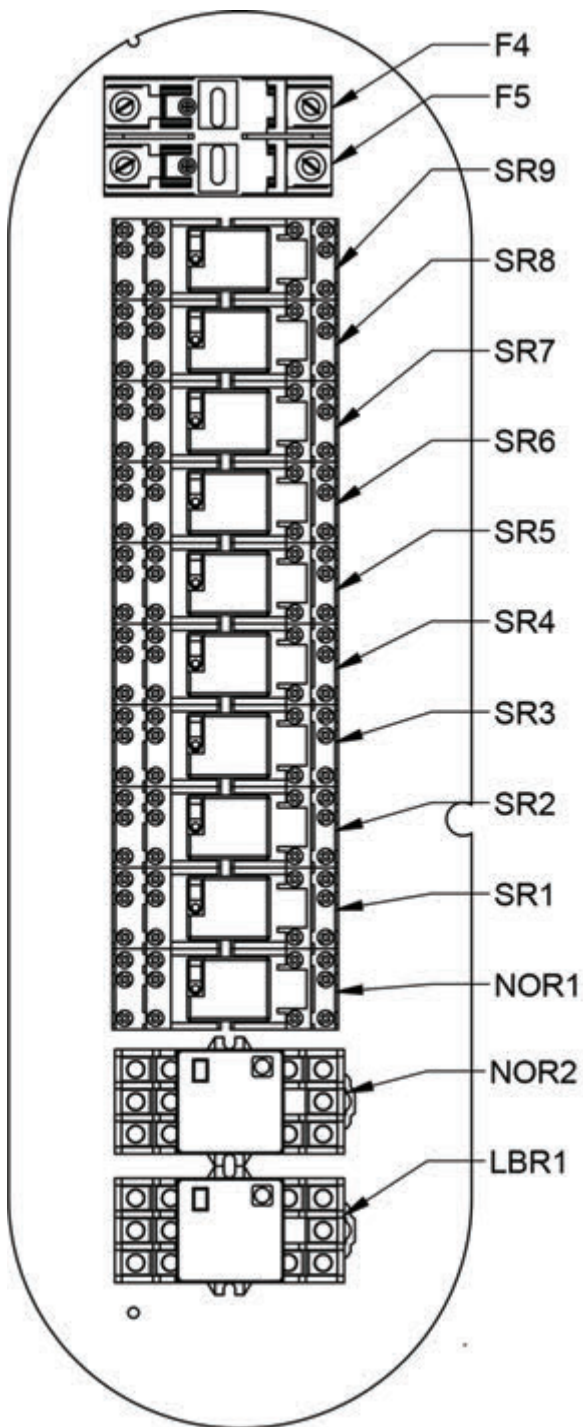

Table 7 Control Relays

Label	Description	Part Number
F4	Fuse, 2A, 600V, Instantaneous	14014500
F5	Fuse, 2A, 600V, Time Delay	14012000
SR9	Relay, 24VDC Coil, 3PDT	24827045
SR8	Relay, 24VDC Coil, 3PDT	24827045
SR7	Relay, 24VDC Coil, 3PDT	24827045
SR6	Relay, 24VDC Coil, 3PDT	24827045
SR5	Relay, 24VDC Coil, 3PDT	24827045
SR4	Relay, 24VDC Coil, 3PDT	24827045
SR3	Relay, 24VDC Coil, 3PDT	24827045
SR2	Relay, 24VDC Coil, 3PDT	24827045
SR2	Relay, 24VDC Coil, 3PDT	24827045
NOR1	Relay, 24VDC Coil, 3PDT	24827045
NOR2	Relay, Large, 24VDC Coil	24816000
LBR1	Relay, Large, 24VDC Coil	24816000

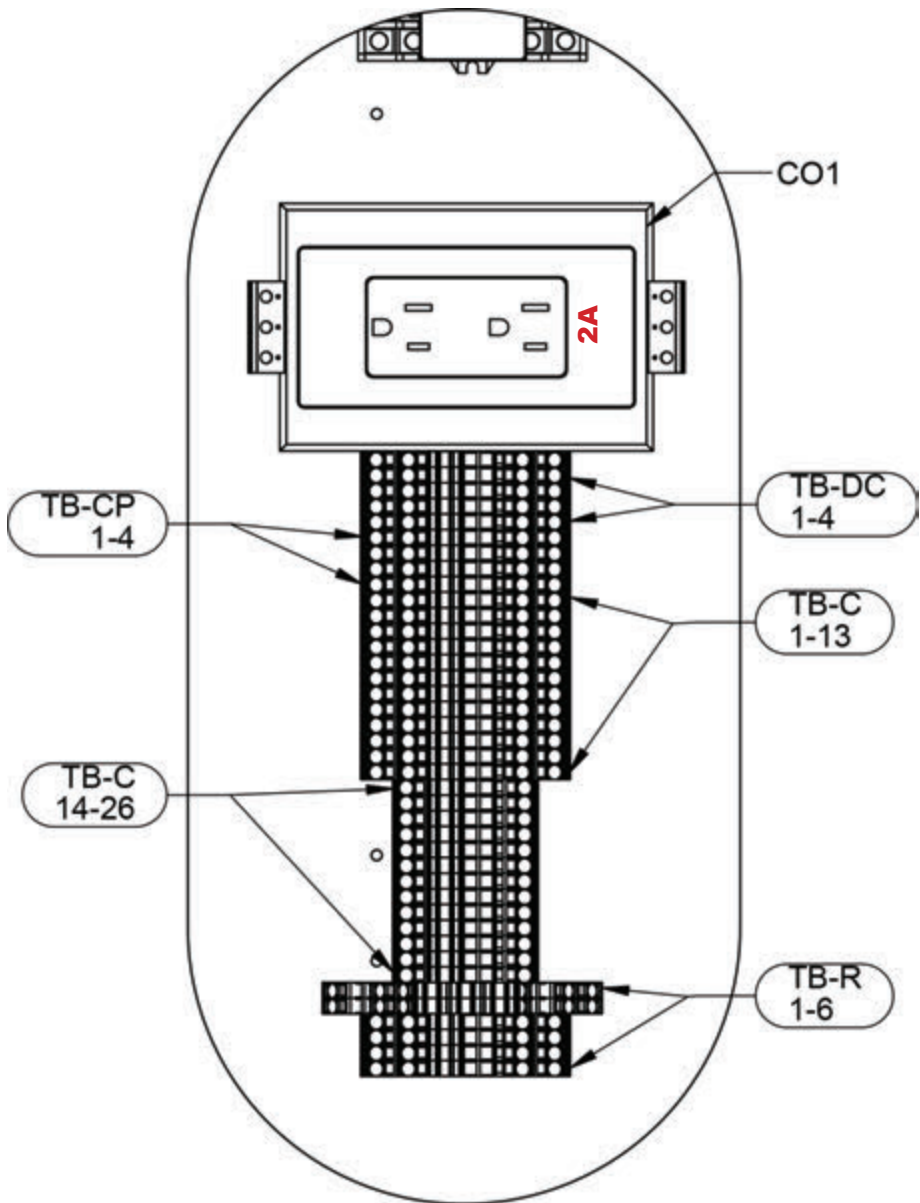

Table 8 Terminal Blocks

Label	Description	Part Number
TB-CP 1-4	Terminal Block, Spring Type, 20A, 600Vac, 4 Connections, Grey	25678536
TB-C 14-26	Terminal Block, Spring Type, 20A, 600Vac, 2 Connections, Grey	25678532
TB-DC 1-2	Terminal Block, Spring Type, 20A, 600Vac, 4 Connections, Red	25678546
TB-DC 3-4	Terminal Block, Spring Type, 20A, 600Vac, 4 Connections, Black	25678547
TB-C 1-13	Terminal Block, Spring Type, 20A, 600Vac, 4 Connections, Grey	25678536
TB-R 1-2	Triple Deck Terminal Block, Spring Type, 24A, Blue	25678550
TB-R 3-6	Terminal Block, Spring Type, 20A, 600Vac, 4 Connections, Grey	25678536
CO1	Outlet, 120Vac, DIN Rail Mount, 15A	25629900

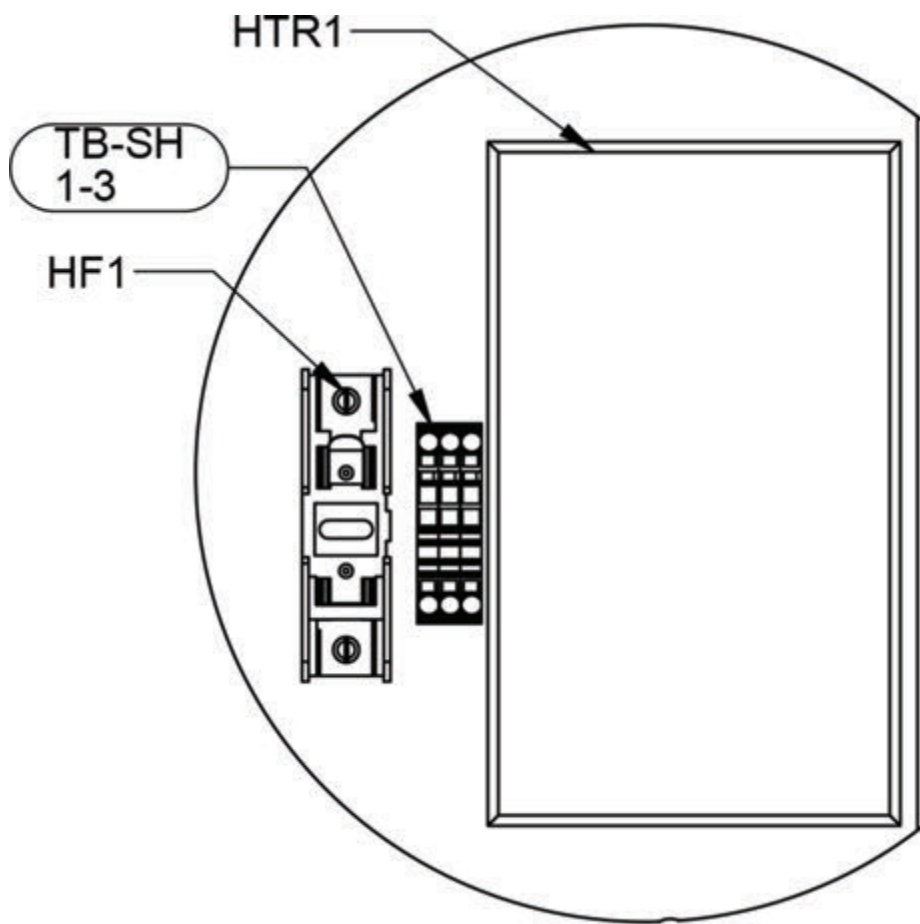

Table 9 Option 010 - Space Heaters

Label	Description	Part Number
TB-SH 1-3	Terminal Block, 2 Connections, Grey	25678532
HF1	Fuse, 7A, Time Delay	14039000
HTR1	Enclosure Heater, 120Vac, 550W w/ Thermostat	25309211

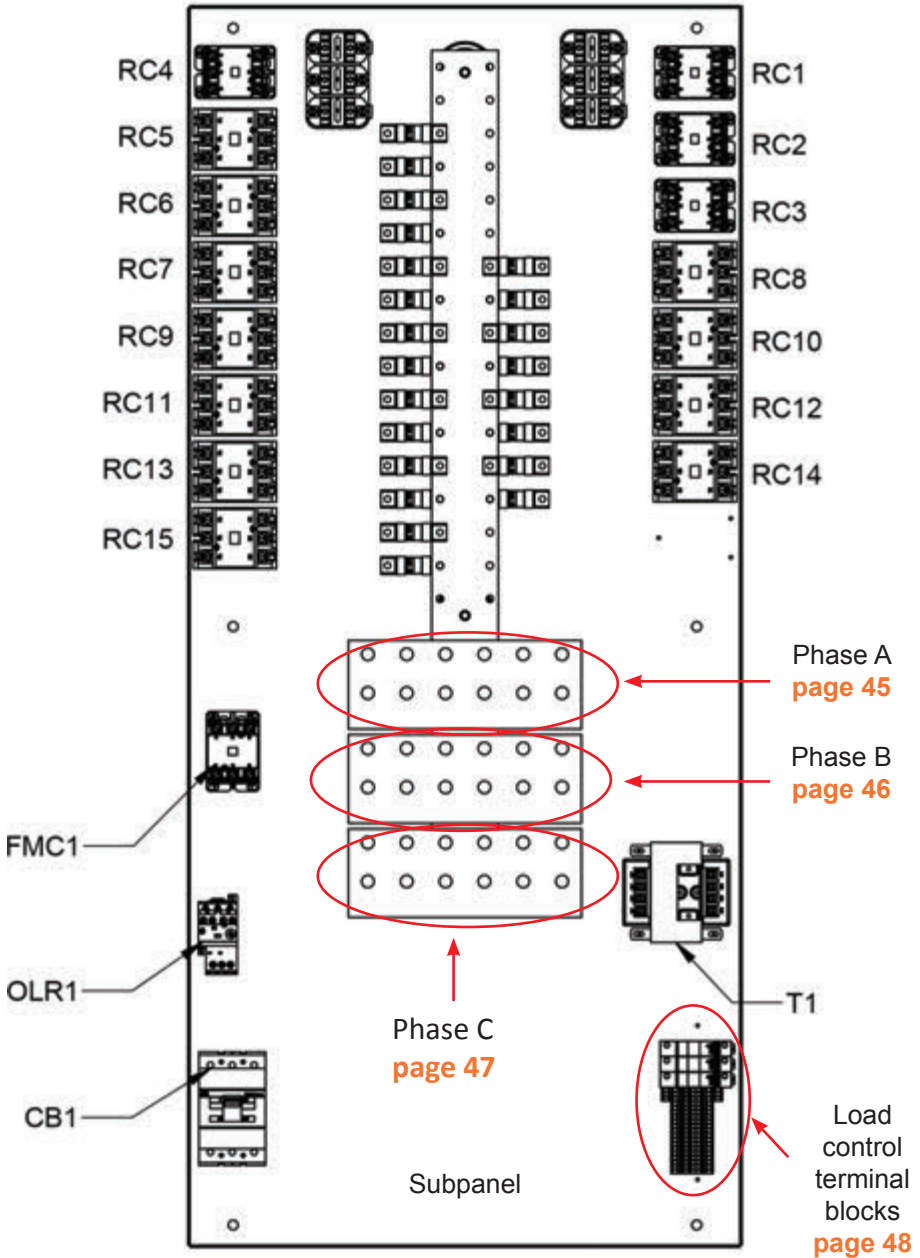

Table 10 Center Subpanel

Label	Description	Part Number
RC 1-6	Contactor, 40A Resistive	13011040
RC5-15	Contactor, 65A Resistive	13011065
FMC1	Contactor, 40A Resistive	13011040
OLR1	Overload Relay, 5.7-18.9A	24827710
CB1	Circuit Breaker, 15A Trip	12046615
T1	Transformer, 300VA, 480/240:240/120Vac	25457650
Subpanel	Subpanel, Neptune, Rear	PRT-00025390

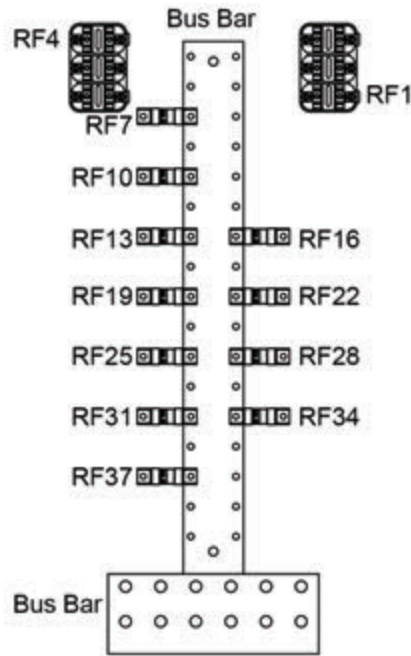

Table 11 Phase A Detail

Label	Description	Part Number
Bus Bar (vertical)	Bus Bar, Single Pole, 750A, Phase A	60044465G
RF4	Fuse, 35A, Class T, Fast Acting	14074000
RF7-34	Fuse, 70A, Class T, Fast Acting	14087000
Bus Bar (horizontal)	Bus Bar, Nept/Mars, 0.250" x 4.00" x10.50"	60063693
RF1	Fuse, 35A, Class T, Fast Acting	14074000

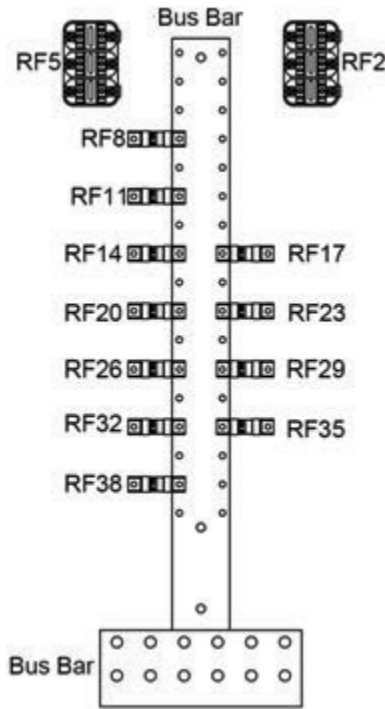

Table 12 Phase B Detail

Label	Description	Part Number
Bus Bar (vertical)	Bus Bar, Single Pole, 750A, Phase B	60044466E
RF5	Fuse, 35A, Class T, Fast Acting	14074000
RF8-35	Fuse, 70A, Class T, Fast Acting	14087000
Bus Bar (horizontal)	Bus Bar, Nept/Mars, 0.250" x 4.00" x10.50"	60063693
RF2	Fuse, 35A, Class T, Fast Acting	14074000

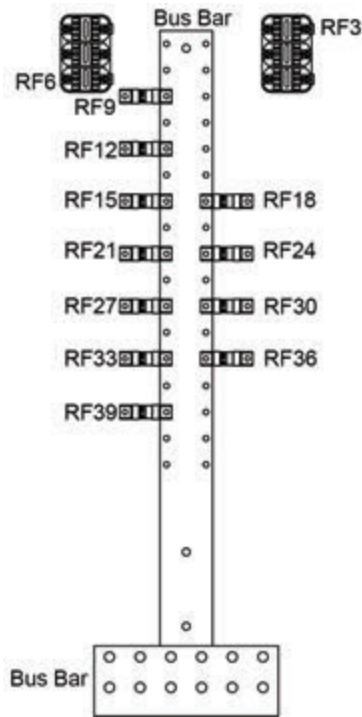

Table 13 Phase C Detail

Label	Description	Part Number
Bus Bar (vertical)	Bus Bar, Single Pole, 750A, Phase C	660044467G
RF6	Fuse, 35A, Class T, Fast Acting	14074000
RF9-36	Fuse, 70A, Class T, Fast Acting	14087000
Bus Bar (horizontal)	Bus Bar, Nept/Mars, 0.250" x 4.00" x10.50"	60063693
RF3	Fuse, 35A, Class T, Fast Acting	14074000

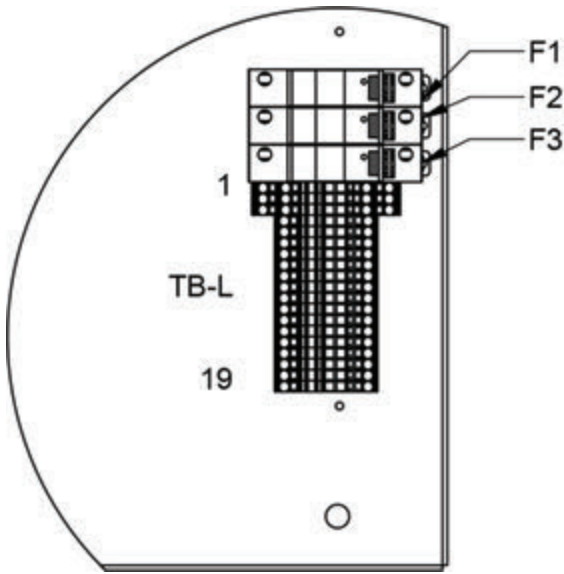

Table 14 Load Control Terminal Blocks

Label	Description	Part Number
F1-2	Fuse, 1.5A, Time Delay	14009500
F3	Fuse, 3.5A, Time Delay	14019775
TB-L 1	Terminal Block, 4 Connections, Black	25678547
TB-L 2	Terminal Block, 4 Connections, Red	25678546
TB-L 3	Terminal Block, 4 Connections, Blue	25678557
TB-L 4-19	Terminal Block, 2 Connections, Grey	25678532

APPENDIX B — MODBUS CONTROLS

Table 15 Modbus Controls (Read/Write)

Name	Type	Function Code	Address
Activate Fan	Coil	01	16586
Apply Load	Coil	01	16704
Cancel Cooldown	Coil	01	16487
KW To Apply	Floating Point	03	28911

Table 16 Modbus Indications (Read only)

Name	Type	Function Code	Address	Notes
Exhaust Alarm	Coil	01	16484	
Fan Failure Alarm	Coil	01	16485	
Load Dump Activated	Coil	01	16486	
Fan Overload Trip	Coil	01	16488	
Intake Temperature Alarm	Coil	01	16489	
Fan Running	Coil	01	8193	
Applied Load	Floating Point	03	29077	
Regulate Mode Active	Coil	01	16705	(a)
Regenerative Sensing Mode Active	Coil	01	16706	(b)
Vab	Floating Point	03	28673	(c)
Vbc	Floating Point	03	28675	(c)

(a) Load Banks with Automatic Load Regulation Only

(b) Load Banks with Regenerative Power Sensing Only

(c) Load Banks with Any Automation Option Only

Name	Type	Function Code	Address	Notes
Vac	Floating Point	03	28677	(c)
Va	Floating Point	03	28679	(c)
Vb	Floating Point	03	28681	(c)
Vc	Floating Point	03	28683	(c)
Ia	Floating Point	03	28685	(c)
Ib	Floating Point	03	28687	(c)
Ic	Floating Point	03	28689	(c)
Watts	Floating Point	03	28691	(c)
VA	Floating Point	03	28693	(c)
VAR	Floating Point	03	28695	(c)

(a) Load Banks with Automatic Load Regulation Only

(b) Load Banks with Regenerative Power Sensing Only

(c) Load Banks with Any Automation Option Only

Name	Type	Function Code	Address	Notes
Power Factor	Floating Point	03	28697	(c)
Watt-Hours	Floating Point	03	28699	(c)
VAR-Hours	Floating Point	03	28701	(c)
Hz	Floating Point	03	28703	(c)

- (a) Load Banks with Automatic Load Regulation Only
- (b) Load Banks with Regenerative Power Sensing Only
- (c) Load Banks with Any Automation Option Only

MODBUS CONTROL DIRECTIONS

1. Ensure that “Regulate Mode Active” (16705) and “Regenerative Sensing Mode Active” (16706) are OFF, indicating that the load bank is ready for Modbus Control
2. Turn “Activate Fan” (16586) ON to energize the cooling fan
3. Verify fan is running by checking that “Fan Running” (8193) is ON
4. Write the desired amount of KW to apply to “KW To Apply” (28911)
5. Turn “Apply Load” (16704) ON to energize the desired amount of load
6. Verify applied load by reading value at “Applied Load” 29077. The load bank will apply as much load as possible to reach the “KW To Apply” value, without exceeding it.
7. Monitor other values as desired.
8. Turn “Apply Load” off to de-energize the load
9. Turn “Activate Fan” OFF to stop the cooling fan. Load bank will continue to operate cooling fan for Cooldown Time set on HMI.
10. Cooldown mode has ended and cooling fan has stopped when “Fan Running” is OFF
11. Cooldown mode can be stopped by writing ON then OFF to “Cancel Cooldown” (16487)



Contact Simplex
for all your Load Bank and Fuel Supply needs.

Simplex, Inc.
5300 Rising Moon Road
Springfield, IL 62711

800-637-8603
www.simplexdirect.com

This manual and all of its contents
Copyright © 2021 Simplex, Inc.
All Rights Reserved.