



ATLAS

Portable Load Bank

Last Revision Date: June 8, 2021

For the most up-to-date information for this product and others,
please contact Simplex, Inc. at (800) 637-8603 or
visit us on the web at <http://www.simplexdirect.com>.

TABLE OF CONTENTS

I. Warnings and Cautions	4
I-A. Safety Information Symbols	4
I-B. Warnings	4
II. Description and Specification	7
II-A. Specifications	7
III. Unpacking	8
III-A. Included Components and Parts	8
III-B. Primary Inspection	8
IV. Installation	9
IV-A. Load Bank Placement	9
IV-B. Wiring the Load Bank	9
V. Operating Instructions	11
V-A. Conducting a Test	11
V-B. Metering Line Trends Screen	11
V-C. Shutdown	12
V-D. Maintenance Mode	12
V-E. Diagnostics Screen	12
VI. Alarms and Warnings	13
VI-A. Sensors	13
VI-B. Alarms	13
VI-C. Warnings	14
VII. Maintenance/Troubleshooting	15
VII-A. General Maintenance	15
VII-B. Each Operation	15
VII-C. Trouble Shooting	15

I. WARNINGS AND CAUTIONS

I-A. Safety Information Symbols

The following images indicate important safety information:



This General warning symbol points out important information that, if not followed, could endanger personal safety and/or property.



This Explosion warning symbol points out potential explosion hazards.



This Fire warning symbol points out potential fire hazards.



This Electrical warning symbol points out potential electrical shock hazards.

I-B. Warnings

This load bank is high-powered, technical, industrial equipment operating at dangerous voltages and temperatures. It is capable of damaging itself, property or personnel if improperly used. It is not a consumer product.

It must be installed, connected and operated by personnel properly trained and experienced in its use. An operator's manual is supplied with each load bank and available online at www.simplexdirect.com. The operator must be familiar with its contents and have access to it during operation.

- **High Voltage:** Turn off and disconnect power source before opening this equipment.
- **High Temperature:** Allow hardware to cool before servicing or opening this equipment.
- **Rotating Equipment:** Ensure that the fans have stopped before opening this unit.
- **For Operator Safety:** Make sure this equipment is properly grounded when in use.

All compression-type connections on fuse blocks, load blocks, and contactors should be checked for tightness frequently. This check should be established as part of routine maintenance.

The following cautions should be observed before and during operation:

- Check intake and exhaust screens as well as fan and load elements for foreign objects.

- Position and install the load bank with consideration given to large cubic airflow requirements, exhaust temperature, and velocity. Do not point exhaust at any nearby surface or object that may be adversely affected by high temperature. This includes but is not limited to painted surfaces, tar paper and asphalt roofs, water sprinkler heads, fire alarms, and volatile material.
- Do not use in confined spaces. The load bank may have to compete with cooling air requirements of a nearby running engine generator set where cooling air intake to a confined space may not be adequate for both engine and load bank. Be especially careful not to bounce hot exhaust air off nearby obstructions for re-circulation through the load bank.
- Verify that all control switch positions are set correctly for your intended usage before connecting the load bank to the source to be tested.
- The load cables carry high amperage. Be constantly aware of possibility of inductively heating adjacent ferrous objects to temperatures sufficient to damage cable insulation.
- Always connect the safety ground cable to a proper ground. Do not rely on a possible grounded neutral somewhere else in the system.
- Do not let the load bank run unattended for long periods of time.
- Do not store or operate in rain unless adequate protection is provided.
- Routinely inspect all components and electrical connections for tightness and integrity.
- Repair any damaged or degraded components and wiring without delay.
- If technical assistance, service, or parts are needed, please call 800-637-8603 (24 Hours).
- All hardware covered by this manual have dangerous electrical voltages and can cause fatal electrical shock. Avoid contact with bare wires, terminals, connections, etc. Ensure all appropriate covers, guards, grounds, and barriers are in place before operating the equipment. If work must be done around an operating unit, stand on an insulated dry surface to reduce the risk of electrocution.
- Do not handle any kind of electrical device while standing in water, while barefoot, or while your hands or feet are wet.
- If people must stand on metal or concrete while installing, servicing, adjusting, or repairing this equipment, place insulative mats over a dry wooden platform. Work on the equipment only while standing on such insulative mats.
- The National Electrical Code (NEC), Article 250 requires the frame to be connected to an approved earth ground and/or grounding rods. This grounding will help prevent dangerous electrical shock that might be caused by a ground fault condition or by static electricity. Never disconnect the ground wire while the load bank is in use.
- Wire gauge sizes of electrical wiring, cables, and cord sets must be adequate to handle the maximum electrical current (ampacity) to which they will be subjected.



- Before installing or servicing this (and related) equipment, ensure that all power voltage supplies are completely turned off at their source. Failure to do so can result in hazardous and possibly fatal electrical shock.
- In case of accident caused by electric shock, immediately shut down the source of electrical power. If this is not possible, attempt to free the victim from the live conductor. AVOID DIRECT CONTACT WITH THE VICTIM. Use a nonconducting implement, such as a dry rope or board, to free the victim from the live conductor. If the victim is unconscious, apply first aid and seek immediate medical attention.
- Never wear jewelry when working on this equipment. Jewelry can conduct electricity resulting in electric shock or may get caught in moving components causing injury.
- Keep a fire extinguisher near the hardware at all times. Do NOT use any carbon tetra-chloride type extinguisher. Its fumes are toxic, and the liquid can deteriorate wiring insulation. Keep the extinguisher properly charged and be familiar with its use. If there are any questions pertaining to fire extinguishers, please consult the local fire department.
- The illustrations in this manual are examples only and may differ from your load bank.
- Load Bank warranty is void if incorrectly cooled.
- Main Disconnect to be provided by installer, rated 600V maximum, sized 150% maximum of rated current.



II. DESCRIPTION AND SPECIFICATION

II-A. Specifications

Capacity	1000KW at 240/480V 750KW at 208/416V 630KW at 380V 667KW at 240V, 1-ph
Power Factor	1.0
Full Load Amps	2404 at 240V 1202 at 480V
Load Type	Resistive
Cooling System	Airflow: 27,700 CFM Motor: 10 HP
Voltages	240/480V, 3-ph.
Frequency	50, 60Hz standard
Connection	3-wire plus ground
Time Rating	Continuous
Ambient Air Temperature	120°F
Fault Rating	Fuses are rated 200KAIC. The load bank has a 5KAIC short circuit current rating.
Fan/Control Power	Provided by either internal transformer or 230/460V, 3-ph, 60Hz external power

III. UNPACKING

III-A. Included Components and Parts

The following items are included with your load bank. If any of the following are not included, please contact Simplex Direct, Inc., at 800-637-8603.

1. Load bank
2. Manual
3. Human-Machine Interface (HMI)
4. Electrical drawings package

III-B. Primary Inspection

Preventative visual inspection of the shipping crate and the load bank is advised. Physical or electrical problems due to handling and vibration may occur. Never apply power to a load bank before performing this procedure. The following five-point inspection is recommended before installation and as part of a 6-month maintenance schedule or as a load bank is relocated:

1. If the crate shows any signs of damage, examine the load bank in the corresponding areas for signs of initial problems.
2. Check the entire outside of the cabinet for any visual damage, which could cause internal electrical or mechanical problems due to reduced clearance.
3. Inspect all relays and control modules. Make sure all components are secure in their bases and safety bails are in place. Spot check electrical connections for tightness. If any loose connections are found, inspect and tighten all remaining connections.
4. Examine all accessible internal electrical components such as fuses, contactors, and relays. Check lugged wires at these components.
5. Visually inspect the element chamber for foreign objects, broken ceramic insulators, and mechanical damage.



If any problems are observed during primary inspection, call Simplex 24 hours a day at 800-637-8603

IV. INSTALLATION

IV-A. Load Bank Placement

Normally equipped, Atlas-Megawatt load banks are intended for outdoor installation. A forced air system, which discharges out of the top of the unit, cools the load elements (pictured right). Load banks require large quantities of air circulation, so it is essential to install the unit in an area that provides adequate airflow. Before conducting load tests, a review of site conditions by trained personnel is recommended.

The load bank requires at least 6 feet of clearance on all sides. Because of the high exhaust temperature, do not install anything above the load bank or install the load bank under existing installations or in environments where objects such as tree branches would be above the unit.

The load bank should be placed in a secure area accessible by trained personnel only.

Because the unit generates a lot of heat, never operate near sprinkler systems.

Operating the load bank in a confined space will recycle hot exhaust air through the cooling system, which can cause severe damage. The load bank may compete with nearby generators for cooling air.

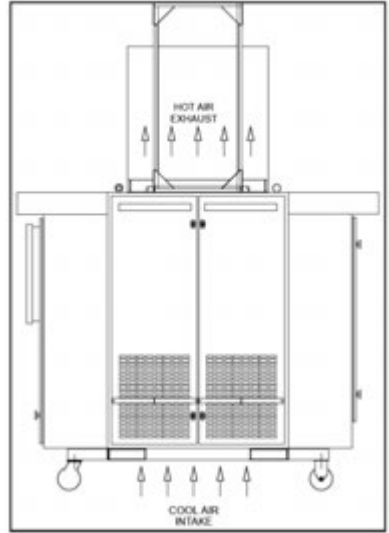

Improperly installing this unit may result in damage or destruction of the load bank, adjacent equipment, and the building housing the unit.

IV-B. Wiring the Load Bank

1. Confirm the test source is properly grounded and ground the load bank to its own independent ground.
2. Verify the Fan Circuit Breaker (FCB) is in the "Off" position.
3. If you will be connecting multiple load banks, use customer-supplied CAT-5, CAT-5E or CAT-6 ethernet cables to create a network by connecting the output of the master load bank to the input of the first slave load bank. Connect as many load banks as desired by daisy-chaining load banks in the same manner.

4. If you will be using the test source to provide control and fan power, plug the Fan/Control Power Plug into the receptacle in the cable-storage area in the back of the load bank. If you will be using external power, plug the Control Power Plug into a 230/460V, 3-phase, 60Hz, 20A receptacle.
5. Using a CAT-5, CAT-5E or CAT-6 ethernet cable, connect the HMI to the main load bank. If other load banks are connected in Step 3, controllers can be connected to them, but they will only provide monitoring for the unit they are connected to.
6. Using the supplied control power cord, connect the HMI controller to the load bank's receptacle in the controller mounting area or a 120V, 1-phase, 60Hz outlet.
7. Using the cables provided, connect the load bank to the testing source.
8. Turn the Fan Circuit Breaker on.

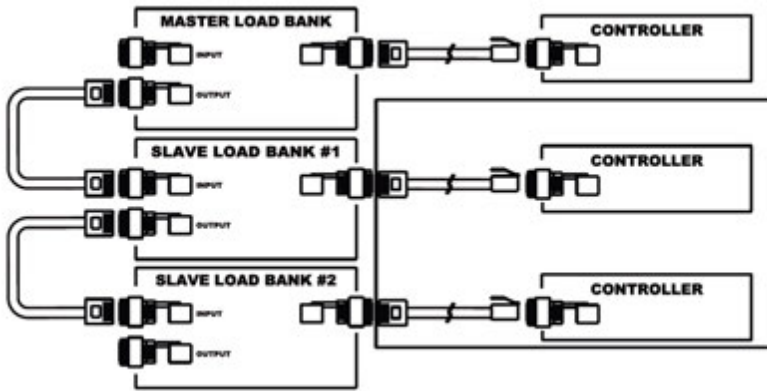

V. OPERATING INSTRUCTIONS

V-A. Conducting a Test

1. If you wish to enable data logging, insert a USB thumb drive into the port underneath the HMI screen.
2. Start up the generator set or otherwise bring the test source on line.
3. Press the “Control Power” to switch it to the “On” position on the Main Screen (pictured above). If multiple units are networked, the Main Screen is only available via the Master Load Bank. Slave units will only display the single-unit monitoring screen (pictured middle).
4. Make sure the fan is spinning, check the air intake for obstructions, confirm air flow and investigate any unusual noise.
5. Make sure no errors are registered in the “System” area in the bottom left of the screen. If any errors are indicated, consult the troubleshooting table on page 16 for information on to resolve them.
6. Adjust the voltage and frequency of the generator.
7. Press the “KW to Apply” button and enter the desired load (pictured bottom).
8. Press the “Apply” button.
9. Monitor and adjust load steps as needed.



V-B. Metering Line Trends Screen



While the load bank is operating, pressing the Metering Line Trends button in the bottom right corner of the screen will bring up the Metering Line Trends screen (pictured left). This screen provides a graph displaying voltage, current, frequency, and kilowatts detected by the load bank.

If you want to record this data, insert a USB drive into the port below the screen and press the “Data Logging Disabled” button. When you are done, press the button again and the load bank will write the data in a tab-delimited format to the thumb drive.

If you have networked multiple load banks together, you can monitor just the master load bank by pressing the “Load Bank Monitoring” button. This will bring up the single-unit monitoring screen.

V-C. Shutdown

1. Remove all load by pressing the Remove button on the main screen.
2. Allow the cooling fan to run for approximately five minutes to provide a thorough cooldown for the entire system.
3. Press the “Control Power” button to switch it to the “Off” position.
4. Turn off the test source.
5. Disconnect the cables and store them in the cable compartment.
6. Disconnect the controller(s) and ethernet cable(s) and store them appropriately.

V-D. Maintenance Mode

While the load bank’s control power is turned off, pressing the “Maintenance Mode” button in the bottom right corner of the screen will make the unit enter maintenance mode (pictured right).

On this screen you can see the values the temperature sensors are reading, the voltages of the three phases, and check the operation of the unit’s load steps by activating them individually.

Any load that you activate on the maintenance screen will be dumped when you leave the screen.



The Factory Setup screen can be accessed from maintenance mode, but it is intended for Simplex service representatives only and is password protected.

V-E. Diagnostics Screen

From the maintenance mode screen, you can enter the Diagnostics screen (pictured right), which displays the status of the load bank’s programmable logic controller.



VI. ALARMS AND WARNINGS

VI-A. Sensors

Atlas-Megawatt load banks are protected by four types of sensors.

1. Intake temperature, which checks the incoming air to ensure the load elements can be adequately cooled.
2. Exhaust temperature, which checks the temperature of the air coming out the load bank to ensure the load elements are being adequately cooled.
3. Fan pressure, when ensures the fan blades are forcing air into the load element chamber.
4. Fan current, which ensures the fan motor isn't overloaded or jammed.



Unresolved cooling issues may result in damage to the load bank.

VI-B. Alarms

If the load bank registers an alarm, the green “Normal Operation” indicator on the main screen will change to a red “Load Bank Failure” notification and the unit will dump the load. Details about the alarm can be found on the Maintenance screen, accessible by pressing the “Maintenance Mode” button.

The load bank’s HMI can alert you to four alarms:

- **Load Bank Failure:** Indicates that there is a problem with the load bank that must be resolved immediately.
- **Exhaust Temp. Failure:** Air leaving the load bank is too hot.
- **Fan Failure:** Either the fan is not pushing cooling air into the element chamber or the fan motor is overloaded.
- **Over Voltage:** Indicates that the load bank has been connected to a power source that produces a higher voltage than the unit is configured for.

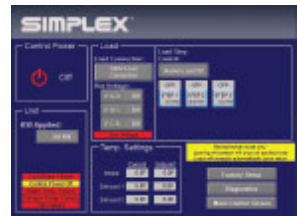

The load bank will alert you to alarms by turning the status areas for the alarm on the home screen from green to red.

VI-C. Warnings

The load bank features one warning: Intake Temp Failure. This warning will not disable the unit and dump the load as with the alarms, but the issue should be investigated and resolved as soon as possible.

VII. MAINTENANCE/TROUBLESHOOTING

VII-A. General Maintenance

The load bank has been designed to require minimum maintenance. All components have been chosen for a long, reliable life. Two basic intervals of maintenance are required: each operation and either every 50 hours of use or 6 months, whichever comes first.

VII-B. Each Operation

The air intake screens and louvers, fan and cooling chamber, and exhaust openings must be checked for any obstructions or foreign objects. Due to the high volume of air circulated, paper and other debris can be drawn into the air intake.

During load bank operation, ensure that air is exiting from the exhaust vent.

The load branches should be checked for blown fuses or opened load resistors. To check the fuses or load resistors, operate the load bank from a balanced 3-phase source and check the three line currents on the metering screen. The three current readings should be essentially the same. If a sizable difference is noted, one or more load fuses or load resistors may have malfunctioned.

VII-C. Trouble Shooting

Any of the alarms detailed on page 13 will result in the load bank entering a failure state and dumping the load. All load steps are locked out until the problem is corrected. Until the failure is investigated and corrected, the load cannot be reapplied. For possible solutions to the problems causing the alarms, please consult “VII-D. Troubleshooting” on page 16. If the load bank still won’t operate, please call the Simplex service department at 800-637-8603 ext. 4.



Remove all power before servicing the load bank. Never operate or service a load bank that is not grounded.

VII-D. Trouble Shooting

Error	Problem	Solution
Intake Temp. Failure	Intake screen blocked by debris	Clear intake screen, located on bottom of unit.
	Ambient temperature too high	Move load bank to cooler location or wait to conduct test on cooler day, if possible.
Exhausts Temp. Failure	Fan has stopped running	The unit needs to be serviced. Please call the Simplex service department at 800-637-8603 ext. 4.
	Exhaust space insufficient	Move the unit to an area that allows for proper air circulation. See "Load Bank Placement" on page 8 for more information.
Fan failure	Fan not blowing air into element chamber	Clear intake screen, located on bottom of unit.
	Fan blades not turning	Make sure nothing has jammed the fan blades.
Over Voltage	Load bank connected to too-high voltage source	Connect load bank to appropriate voltage source.



Contact Simplex
for all your Load Bank and Fuel Supply needs.

Simplex, Inc.
5300 Rising Moon Road
Springfield, IL 62711

800-637-8603
www.simplexdirect.com

This manual and all of its contents
Copyright © 2021 Simplex, Inc.
All Rights Reserved.